

International Energy Agency

# Long-Term Performance of Super-Insulating Materials in Building Components and Systems

Energy in Building and Communities Programme

Ulrich Heinemann (Editor)



International Energy Agency, EBC Annex 65

# Long-Term Performance of Super-Insulating Materials in Building Components and Systems

---

## Report of Subtask I: State of the Art and Case Studies

03 January 2020

### Editor:

Ulrich Heinemann

[ulrich.heinemann@zae-bayern.de](mailto:ulrich.heinemann@zae-bayern.de)

Bavarian Centre for Applied Energy Research

ZAE Bayern

Magdalene-Schoch-Str. 3

97074 Würzburg / Germany

<http://www.zae-bayern.de>

## **Chapter 1:**

### **Authors:**

Daniel Quenard, CSTB, France (Operating Agent)  
Ulrich Heinemann, ZAE Bayern, Germany (Editor and Subtask leader Subtask 1)

### **With contributions from:**

Bernard Yrieix, EDF, France

## **Chapter 2:**

### **Authors:**

Ulrich Heinemann, ZAE Bayern, Germany  
Christoph Sprengard, FIW Munich, Germany (Subtask leader Subtask 2)  
Bernard Yrieix, EDF, France

### **With contributions from:**

Phalguni Mukhopadhyaya, Univ. of Victoria, Canada

## **Chapter 3:**

### **Authors:**

Barbara Milow, DLR, Germany  
Samuel Brunner Empa, Switzerland  
Geneviève Foray (INSA de Lyon, France)

### **With contributions from:**

Bernard Yrieix, EDF, France  
Ulrich Heinemann, ZAE Bayern, Germany  
Christoph Sprengard, FIW Munich, Germany  
Michael O'Conner, ASPEN Aerogel, USA  
Bettina Gerharz-Kalte, Gabriele Gärtner and Matthias Geisler, Evonik, Germany  
Miltiadi Vlachos and Georg Gärtner, Cabot, Germany/USA  
Pierre-André Marchal and Brice Fiorentino, Enersens, France

## **Chapter 4:**

### **Authors:**

Ulrich Heinemann, ZAE Bayern, Germany  
Samuel Brunner Empa, Switzerland  
Esra Kucukpinar, IVV, Germany

### **With contributions from:**

Bjørn-Petter Jelle, Sintef, Norway  
Christoph Sprengard, FIW Munich, Germany  
Phalguni Mukhopadhyaya, Univ. of Victoria, Canada  
Yoash Carmi, Hanita Coatings, Israel  
Guy Veyrier du Muraud, Toray Films Europe, France

Pascal Rousset, Rexor, France  
Kazuma Kugimiya, Panasonic, Japan  
Yohei Sasaki, Kururay/EVAL Europe, Belgium  
Gregor Erbenich and Hans-Frieder Eberhardt, Porextherm Dämmstoffe GmbH, Germany  
Anca Zafir and Ulrich Passon, Saint-Gobain Isover, Germany/France  
Erol Serpil, Metra-Group, Japan/Turkey/Germany  
Atsuchi Iwamae, Kyoto, Japan  
Yi He, Creek, China

## **Chapter 5:**

### **Authors:**

Bijan Adl-Zarrabi (Subtask leader Subtask 3) and  
Pär Johansson, both Chalmers University, Sweden

### **With contributions from:**

Ulrich Heinemann, ZAE Bayern, Germany  
Kjartan Gudmundsson, KTH, Sweden  
Michael O’Conner, ASPEN Aerogel, USA  
Gabriele Gärtner, Evonik, Germany  
Ulrich Passon, Saint-Gobain Isover, Germany/France

## **Chapter 6:**

### **Authors:**

Bijan Adl-Zarrabi (Subtask leader Subtask 3) and  
Pär Johansson, both Chalmers University, Sweden

### **With contributions from:**

Atsuchi Iwamae, Kyoto, Japan  
Phalguni Mukhopadhyaya, Univ. of Victoria, Canada  
Bjørn-Petter Jelle, Sintef-NTNU, Norway

## **Chapter 7:**

### **Authors:**

Holger Wallbaum, (Subtask leader Subtask 4) and  
Yun Kono, both (Chalmers University, Sweden)

### **External Reviewers:**

Daniel van Rijn: The Netherlands  
Rolf Moser: Switzerland

© Copyright CSTB 2020

All property rights, including copyright, are vested in CSTB, Operating Agent for EBC Annex 65, on behalf of the Contracting Parties of the International Energy Agency Implementing Agreement for a Programme of Research and Development on Energy in Buildings and Communities. In particular, no part of this publication may be reproduced, stored in a retrieval system or transmitted in any form or by any means, electronic, mechanical, photocopying, recording or otherwise, without the prior written permission of CSTB (Operating Agent of Annex 65) or ZAE Bayern (Editor).

Published by CSTB, France

Disclaimer Notice: This publication has been compiled with reasonable skill and care. However, neither CSTB nor the EBC Contracting Parties (of the International Energy Agency Implementing Agreement for a Programme of Research and Development on Energy in Buildings and Communities) make any representation as to the adequacy or accuracy of the information contained herein, or as to its suitability for any particular application, and accept no responsibility or liability arising out of the use of this publication. The information contained herein does not supersede the requirements given in any national codes, regulations or standards, and should not be regarded as a substitute for the need to obtain specific professional advice for any particular application.

ISBN: xxxx

Participating countries in EBC:

Australia, Austria, Belgium, Canada, P.R. China, Czech Republic, Denmark, Finland, France, Germany, Greece, Ireland, Italy, Japan, Republic of Korea, the Netherlands, New Zealand, Norway, Poland, Portugal, Spain, Sweden, Switzerland, Turkey, United Kingdom and the United States of America.

Additional copies of this report may be obtained from:

[www.iea-ebc.org](http://www.iea-ebc.org)

[essu@iea-ebc.org](mailto:essu@iea-ebc.org)

The photos on the cover depict examples of the two types of super insulation materials considered in this Annex: vacuum insulation panels VIP (photo on the left, © POREXTHERM) and the so called advanced porous materials APM (photo on the right side, © ASPEN AEROGEL).

# Preface

## The International Energy Agency

The International Energy Agency (IEA) was established in 1974 within the framework of the Organisation for Economic Co-operation and Development (OECD) to implement an international energy programme. A basic aim of the IEA is to foster international co-operation among the 28 IEA participating countries and to increase energy security through energy research, development and demonstration in the fields of technologies for energy efficiency and renewable energy sources.

## The IEA Energy in Buildings and Communities Programme

The IEA co-ordinates research and development in a number of areas related to energy. The mission of the Energy in Buildings and Communities (EBC) Programme is to develop and facilitate the integration of technologies and processes for energy efficiency and conservation into healthy, low emission, and sustainable buildings and communities, through innovation and research. (Until March 2013, the IEA-EBC Programme was known as the Energy in Buildings and Community Systems Programme, ECBCS.)

The research and development strategies of the IEA-EBC Programme are derived from research drivers, national programmes within IEA countries, and the IEA Future Buildings Forum Think Tank Workshops. The research and development (R&D) strategies of IEA-EBC aim to exploit technological opportunities to save energy in the buildings sector, and to remove technical obstacles to market penetration of new energy efficient technologies. The R&D strategies apply to residential, commercial, office buildings and community systems, and will impact the building industry in five focus areas for R&D activities:

- Integrated planning and building design
- Building energy systems
- Building envelope
- Community scale methods
- Real building energy use

## The Executive Committee

Overall control of the IEA-EBC Programme is maintained by an Executive Committee, which not only monitors existing projects, but also identifies new strategic areas in which collaborative efforts may be beneficial. As the Programme is based on a contract with the IEA, the projects are legally established as Annexes to the IEA-EBC Implementing Agreement. At the present time, the following projects have been initiated by the IEA-EBC Executive Committee, with completed projects identified by (\*):

- Annex 1: Load Energy Determination of Buildings (\*)
- Annex 2: Ekistics and Advanced Community Energy Systems (\*)
- Annex 3: Energy Conservation in Residential Buildings (\*)
- Annex 4: Glasgow Commercial Building Monitoring (\*)
- Annex 5: Air Infiltration and Ventilation Centre
- Annex 6: Energy Systems and Design of Communities (\*)
- Annex 7: Local Government Energy Planning (\*)
- Annex 8: Inhabitants Behaviour with Regard to Ventilation (\*)
- Annex 9: Minimum Ventilation Rates (\*)
- Annex 10: Building HVAC System Simulation (\*)
- Annex 11: Energy Auditing (\*)
- Annex 12: Windows and Fenestration (\*)
- Annex 13: Energy Management in Hospitals (\*)
- Annex 14: Condensation and Energy (\*)
- Annex 15: Energy Efficiency in Schools (\*)
- Annex 16: BEMS 1- User Interfaces and System Integration (\*)
- Annex 17: BEMS 2- Evaluation and Emulation Techniques (\*)
- Annex 18: Demand Controlled Ventilation Systems (\*)
- Annex 19: Low Slope Roof Systems (\*)

- Annex 20: Air Flow Patterns within Buildings (\*)
  - Annex 21: Thermal Modelling (\*)
  - Annex 22: Energy Efficient Communities (\*)
  - Annex 23: Multi Zone Air Flow Modelling (COMIS) (\*)
  - Annex 24: Heat, Air and Moisture Transfer in Envelopes (\*)
  - Annex 25: Real time HVAC Simulation (\*)
  - Annex 26: Energy Efficient Ventilation of Large Enclosures (\*)
  - Annex 27: Evaluation and Demonstration of Domestic Ventilation Systems (\*)
  - Annex 28: Low Energy Cooling Systems (\*)
  - Annex 29: Daylight in Buildings (\*)
  - Annex 30: Bringing Simulation to Application (\*)
  - Annex 31: Energy-Related Environmental Impact of Buildings (\*)
  - Annex 32: Integral Building Envelope Performance Assessment (\*)
  - Annex 33: Advanced Local Energy Planning (\*)
  - Annex 34: Computer-Aided Evaluation of HVAC System Performance (\*)
  - Annex 35: Design of Energy Efficient Hybrid Ventilation (HYBVENT) (\*)
  - Annex 36: Retrofitting of Educational Buildings (\*)
  - Annex 37: Low Exergy Systems for Heating and Cooling of Buildings (LowEx) (\*)
  - Annex 38: Solar Sustainable Housing (\*)
  - Annex 39: High Performance Thermal Insulation Systems (\*)
  - Annex 40: Building Commissioning to Improve Energy Performance (\*)
  - Annex 41: Whole Building Heat, Air and Moisture Response (MOIST-ENG) (\*)
  - Annex 42: The Simulation of Building-Integrated Fuel Cell and Other Cogeneration Systems (FC+COGEN-SIM) (\*)
  - Annex 43: Testing and Validation of Building Energy Simulation Tools (\*)
  - Annex 44: Integrating Environmentally Responsive Elements in Buildings (\*)
  - Annex 45: Energy Efficient Electric Lighting for Buildings (\*)
  - Annex 46: Holistic Assessment Tool-kit on Energy Efficient Retrofit Measures for Government Buildings (EnERGo) (\*)
  - Annex 47: Cost-Effective Commissioning for Existing and Low Energy Buildings (\*)
  - Annex 48: Heat Pumping and Reversible Air Conditioning (\*)
  - Annex 49: Low Exergy Systems for High Performance Buildings and Communities (\*)
  - Annex 50: Prefabricated Systems for Low Energy Renovation of Residential Buildings (\*)
  - Annex 51: Energy Efficient Communities (\*)
  - Annex 52: Towards Net Zero Energy Solar Buildings (\*)
  - Annex 53: Total Energy Use in Buildings: Analysis & Evaluation Methods (\*)
  - Annex 54: Integration of Micro-Generation & Related Energy Technologies in Buildings (\*)
  - Annex 55: Reliability of Energy Efficient Building Retrofitting - Probability Assessment of Performance & Cost (RAP-RETRO)
  - Annex 56: Cost Effective Energy & CO<sub>2</sub> Emissions Optimization in Building Renovation
  - Annex 57: Evaluation of Embodied Energy & CO<sub>2</sub> Equivalent Emissions for Building Construction
  - Annex 58: Reliable Building Energy Performance Characterisation Based on Full Scale Dynamic Measurements
  - Annex 59: High Temperature Cooling & Low Temperature Heating in Buildings
  - Annex 60: New Generation Computational Tools for Building & Community Energy Systems
  - Annex 61: Business and Technical Concepts for Deep Energy Retrofit of Public Buildings
  - Annex 62: Ventilative Cooling
  - Annex 63: Implementation of Energy Strategies in Communities
  - Annex 64: LowEx Communities - Optimised Performance of Energy Supply Systems with Exergy Principles
  - Annex 65: Long Term Performance of Super-Insulating Materials in Building Components and Systems
  - Annex 66: Definition and Simulation of Occupant Behavior Simulation
  - Annex 67: Energy Flexible Buildings
  - Annex 68: Design and Operational Strategies for High IAQ in Low Energy Buildings
  - Annex 69: Strategy and Practice of Adaptive Thermal Comfort in Low Energy Buildings
- Working Group - Energy Efficiency in Educational Buildings (\*)
- Working Group - Indicators of Energy Efficiency in Cold Climate Buildings (\*)
- Working Group - Annex 36 Extension: The Energy Concept Adviser (\*)

## Summary

The objective of this subtask I is to present the main characteristic of SIM (Super Insulating Materials) compared to traditional materials.

Two main SIM are considered:

- VIP (Vacuum Insulation Panel)
- APM (Advanced Porous Materials).

Moreover, the present report provides an up-to-date catalogue of commercially available materials & components with technical description and data of each product and information about the application domains and the implementation rules.

An overview on all the application areas such as external & internal wall insulation, roofs, floors, ceilings ...are investigated through a few case studies.

Finally, preliminary results about Life Cycle Assessment of SIM are presented at the end of the report



# Table of content

Energy in Building and Communities Programme	1
Preface	i
Summary	iii
Abbreviations	vii
Definitions	viii
1 Introduction	1
1.1 General context	1
1.2 Objectives of IEA-EBC Annex 65 for the development of Super-Insulating Materials SIM	2
1.3 Deliverables & Target Audience	5
2 Super-Insulating Materials	7
2.1 Description of SIM	7
2.2 Some basic physics on heat transfer in thermal insulation materials	9
2.3 Thermal performance of SIM	13
2.4 Enhanced influence of thermal bridging	14
2.4.1 General	14
2.4.2 Numerical determination of the overall performance	16
2.4.3 Experimental approach to determine the overall thermal performance	19
2.5 Long Term Performance - Ageing Mechanisms	20
2.5.1 Introduction	20
2.5.2 Evolution of the radiative conductivity	21
2.5.3 Evolution of the solid conductivity	22
2.5.4 Evolution of the gaseous conductivity	25
2.5.5 Permeation through the barrier	27
2.5.6 Practical Approach (for VIP)	30
3 Advanced Porous Materials	33
3.1 Description of APM	34
3.2 Characterisation methods for APM	36
3.2.1 Thermal Conductivity	36

3.2.2	Water vapour permeability	36
3.2.3	Hydrophobicity	36
3.2.4	Fire Classification	37
3.2.5	Freeze and thaw	37
3.2.6	Health and safety	37
3.2.7	Wettability	37
3.2.8	Mechanical properties	37
3.2.9	Density	37
3.2.10	Structural characterisation	38
3.2.11	Thermal chemical properties	38
3.2.12	Long-term performance	38
3.3	Long-term performance of APM	39
3.3.1	Initial thermal performance	39
3.3.2	Failure mode and ageing, long-term performance	39
4	Vacuum Insulation Panels	41
4.1	Description of Products	41
4.2	Description of Core Materials	45
4.2.1	Different Core Materials (Data)	47
4.2.2	Characterisation Methods Core Materials	50
4.3	Description of the Envelope	53
4.3.1	VIP Envelope Structures	55
4.3.2	Sealed Seams	57
4.3.3	Characterisation Methods	59
4.4	Description of Getters und Desiccants	76
4.5	Characterisation Methods for VIP	79
4.5.1	Thermal Conductivity	80
4.5.2	Internal Gas Pressure	91
4.5.3	Long Term Performance of VIP	93
4.5.4	Round-Robin Tests	95
4.6	Standardisation, Norms, Approvals, Certifications	97
4.6.1	Canada	97

4.6.2	China	97
4.6.3	Germany, France, Switzerland	98
4.6.4	European Union	98
4.6.5	North America	99
4.6.6	Japan	100
4.6.7	South Korea	101
4.6.8	An Example – Accelerated Ageing Test Protocol for CANADA	101
5	Products and Components	103
5.1	Building products and components with VIP	103
5.2	Building products and components with APM	114
5.3	Installation guidelines	120
5.4	Case Studies	121
6	Life Cycle Assessment	126
6.1	Existing studies of LCA on SIMs	127
6.2	International projects on LCA of SIMs	129
6.2.1	VIP	129
6.2.2	APM	129
6.3	EPD of SIMs	129
6.3.1	VIP	129
6.3.2	APM	129
6.4	LCA on SIM applications	130
6.4.1	VIP	130
6.4.2	APM	130
6.5	Summary of the state-of-the-art of LCA of SIMs	130
6.6	Embodied energy	131
6.7	Life cycle cost calculation	131
7	Conclusion	133
	References	134

# Abbreviations

Table 1: List of frequently used abbreviations

Abbreviations	Meaning
APM	Advanced porous material
ASTM	American Society for Testing and Materials International, an international standards organization
CEN	European Committee for Standardization (Comité Européen de Normalisation)
DHW	Domestic hot water
EE	Embodied Energy
EN	European Norm
EPBD	Energy Performance of Buildings Directive
EOTA	European Organisation for Technical Approvals
GHP	Guarded hot plate
HFM	Heat flow meter
IEA-EBC	Energy in Buildings and Communities Programme of the International Energy Agency
ISO	International Organization for Standardization
LCA	Life cycle Assessment
LCI	Life cycle Impact
LCIA	Life cycle impact analysis
$\lambda$	Thermal Conductivity [W/(m K)]
NZEB	Nearly zero energy building or nearly zero emissions building
SIM	Super Insulating Material
ST 1	Annex 65 Subtask 1: State of the Art on Materials & Components - Case Studies
ST 2	Annex 65 Subtask 2: Characterisation of materials & components - Laboratory Scale
ST 3	Annex 65 Subtask 3: Practical Applications – Retrofitting at the Building Scale – Field scale
ST 4	Annex 65 Subtask 4: Sustainability – LCC, LCA, EE – Risk & Benefit
UEATc	Union Européenne pour l'Agrément technique dans la construction a grouping of 18 approval bodies in Europe
U-value	Thermal transmittance of a building element [W/(m <sup>2</sup> K)]
VIP	Vacuum insulation panel

# Definitions

**Definitions of energy performance** according to EN 15603:2008 (Official Journal of the EU, 19.4. 2012, p. C 115/9) and econcept (embodied energy):

- **Thermal conductivity:** the amount of heat per unit time per unit area that can be conducted through a plate of unit thickness of a given material, the faces of the plate differing by one unit of temperature.
- **Energy need for heating or cooling:** heat to be delivered to or extracted from a conditioned space to maintain intended temperature conditions during a given period of time.
- **Energy need for domestic hot water:** heat to be delivered to the needed amount of domestic hot water to raise its temperature from the cold network temperature to the prefixed delivery temperature at the delivery point.
- **Energy use for space heating or cooling or domestic hot water:** energy input to the heating, cooling or hot water system to satisfy the energy need for heating, cooling or hot water respectively.
- **Embodied energy:** Embodied energy is the total energy required for the extraction, processing, manufacture and delivery of building materials to the building site.
- **Primary energy:** Energy found in the nature that has not been subject to any conversion or transformation process. It is energy contained in raw fuels and other forms of energy received as input. It can be non-renewable or renewable.

**Definitions of building life cycle** according to ISO 14040:2006:

- **LCA:** Life cycle assessment: compilation and evaluation of the inputs, outputs and the potential environmental impacts of a product system throughout its life cycle.
- **LCIA:** Life cycle impact assessment: phase of life cycle assessment aimed at understanding and evaluating the magnitude and significance of the potential environmental impacts of a product system.

# 1 Introduction

## 1.1 General context

In the Building Sector, Space Heating (SH) and Domestic Hot Water (DHW) remain the most important energy users. Moreover, refrigeration & freezers (RF) account for around 25% of the whole household appliances. Finally, SH, DHW and RF represent about 80% of the total energy consumption of household used to fulfil their needs for comfort, sanitary conditions and food storage and unfortunately, most of this energy is wasted through heat losses and not used on purpose. Since the first oil crisis, the implementation of Building Regulations (Vermande & van der Heijden, 2011) through a combination of higher efficiencies of heating, ventilation and cooling systems and improved thermal performance of building envelope leads to a significant reduction in the per capita energy requirement for SH. Unfortunately, these efforts do not balance the increasing of energy consumption of appliances (especially small ones) and air-conditioning in a few countries.

The potential of energy saving has been estimated to be close to the energy consumption in the transport sector (WBCSD, 2009) and the current challenge is to make this potential a reality. The first target is to ensure that new buildings do not place additional strain upon energy resources. This goal can be reached by developing Net Zero Energy Building (NZEB) as defined in the Annex 52 (Annex 52, 2014) and promoted in the Energy Performance of Buildings Directive (EPBD) recast in 2010 (EU Directive 2010/31/EU, 2010). However, in most industrialised countries the construction of new buildings (mainly NZEB buildings) will only contribute between 10% to 20% of additional energy consumption by 2050 whereas more than 80% will be influenced by the existing building stock and 75% of current buildings in OECD will still be standing in 2050. Accordingly, building renovation has a high priority in many countries, and it plays an important role in the building related IEA R&D programs. Hence, the big challenge is existing buildings as these represent such a high proportion of energy consumption and they will be with us for many decades to come. According to the IEA BLUE map scenario, two-thirds of the energy savings come from the residential sector and the improvements in the building envelope coupled with energy savings in electrical end-uses dominate total CO<sub>2</sub> reductions.

Furthermore, several studies (Verbeeck & Hens, 2005; Enkvist et al., 2007; Schüle et al., 2013) have shown that the most efficient way to curb the energy consumption in the building sector (new & existing) remain the reduction of the heat loss by improving the insulation of the building envelope (roof, floor, wall & windows).

## 1.2 Objectives of IEA-EBC Annex 65 for the development of Super-Insulating Materials SIM

An extensive renovation of existing buildings & NZEB appear as the future tracks for 2050, in the building sector and the thermal performance of the envelope is a top priority to make both objectives a success.

SIM should greatly contribute to this challenge if reliable data (properties & durability) and secure implementation techniques are provided to the supply chain (designers, engineers & builders).

The sustainability study of super-insulating materials SIM (LCA, LCC, Embodied Energy ...) will be a complementary aspect of this study.

Therefore, the current research proposal has the following objectives:

- to make a state of the art of a decade of development of SIM by the industry and of applications in the building sector,
- to develop experimental & numerical tools to provide reliable data (properties & durability) for manufacturers and designers,
- to write guidelines for secure installation,
- to support standardisation and assessment procedures,
- to improve knowledge and confidence of the supply chain regarding SIM, thanks to sustainability analysis,
- to foster a wider public acceptance of SIM in the future by communication.

These objectives are pursued by the subsequent four Subtasks (ST 1, ST 2, ST 3, ST 4):

### **SUBTASK 1: State of the Art on Materials & Components - Case Studies**

Subtask Leader: ZAE Bayern

This subtask will be split in three actions (topics):

Action 1A: Materials & Characterisation Methods

Action 1B: Components & Systems

Action 1C: Case Studies at the Building Scale

The main objective of this subtask is to provide an up-to-date catalogue of commercially available materials & components. This catalogue will provide technical description of each product with technical data and information about the application domains and the implementation rules.

Furthermore, during the last decade, basic research and first demonstration projects (Heinemann & Kastner, 2010; Flamant et al., 2012) have shown that SIM are in many case the only way to achieve both efficient energy retrofitting and service ability of buildings (where any inside space reduction is prohibited for instance). Moreover, SIM started to be applied in conventional projects. For the use in buildings in the recent years

first ETAs (European Technical Approvals, until 06/2013, and European Technical Assessments, from 07/2013) have been issued for vacuum insulation panels VIP and so-called advanced porous materials APM (e.g. ETA-11/0414, ETA-11/0471, ETA-13/0493, ETA-13/0515, ETA-13/1026, ETA-15/0090) (European Commission, 2013). However, a large use of these components is still hindered by the higher price level in comparison to common insulation materials and especially for VIP the scepticism on the reliability in practice. In order to improve the confidence in these new components and in order to move towards by design reliable cost-efficient SIM for the future this subtask will make a detailed analysis of such components offered by manufacturers. An overview on all the application areas such as external & internal wall insulation, roofs, floors, ceilings, etc. will be investigated through a few case studies.

All the materials & components manufacturers will contribute to this subtask.

## **SUBTASK 2: Characterisation of materials & components - Laboratory Scale**

Subtask Leader: FIW Munich (Christoph Sprengard, Christine Mayer)

This subtask is divided in two actions:

Action 2A: Materials Assessment & Ageing Procedures (Experiments & Simulation)

Action 2B: Components & Systems Assessment (Experiments & Simulation)

As their structure and microstructure are completely different, SIM cannot be compared directly to traditional insulating materials, but worldwide acceptance of these materials will be improved, if the hygro-thermal and mechanical properties of SIM can be declared clearly and reproducibly. In particular, nano-structured raw materials used to manufacture SIM are characterised by a high specific area ( $\text{m}^2/\text{g}$ ) and narrow pores (smaller than  $1 \mu\text{m}$ ) which make them very sensitive to gas adsorption and condensation, especially with water molecules. Beside those raw materials, SIM may include additives (fibre, opacifier ...), and those could interfere with some characterisation methods.

Therefore, the methods of characterisation must be adapted and even in some cases new methods have to be developed. A multiscale description of the material might be necessary or helpful, which makes a difference between raw nano-structured material, formulated material (the nano-structured + additives + opacifier...) and the full product ready to use on site. This includes tests on the microstructural, hygro-thermal and mechanical properties of raw materials and barrier films, or superinsulation products.

In parallel, multiscale modelling methods to describe heat, moisture and air transfer through nano-structured materials and films will be developed (adsorption and desorption models, diffusion models, freezing-thawing ...).

Of course, a few methods will be common to all SIM, but due to the principle differences in composition some specific methods must be developed.



SIM can offer considerable advantages; however, potential drawback effects should be known and considered in the planning process to optimise the development of these extraordinary properties and to prevent negative publicity, which could be detrimental to this sector of emerging products. It is why ageing tests will be defined according to the conditions in use (temperature, moisture, pressure, load ...) defined in Subtask 3A. One objective of artificial ageing is to understand potential degradation processes that could occur. The durability of the hydrophobic treatment is one of these processes and will also be subject of discussion and investigation.

At the component scale, additional characterisations are needed as in general panels or rolls are sold by manufacturers. In particular, thermal bridges will be carefully investigated, as the extraordinary thermal performance of SIM is sensitive for the influence of thermal bridges.

### **SUBTASK 3: Practical Applications – Retrofitting at the Building Scale – Field scale**

Subtask Leader: Chalmers University (Bijan Adl-Zarrabi)

This subtask will be separated in three actions:

Action 3A: Mapping of the Use Conditions (Components & Systems)

Action 3B: Performance at the Building Scale (Experiments & Simulation)

Action 3C: Practical Applications focused on Retrofitting

The objective of this task will be to define the application areas of SIM and to describe the conditions of the intended use of the products. Indeed, it is clear that the requested performance of the SIM will strongly depend on the temperature, humidity and load conditions.

For building applications, storage, handling and implementation requirements will be also described.

Common and specific modelling methods will be also developed at the building scale in order to understand the impact of SIM on the performance of wall, roof and floors and even the whole envelope with regards mainly to thermal insulation, airtightness and risk of condensation.

This task will be carried out in conjunction with the Annex 58 devoted to the “Reliable Building Energy Performance Characterisation based on Full Scale Dynamic Measurement” (Annex 58, 2016) and with the Annex 61 “Business and Technical Concepts for Deep Energy Retrofit of Public Buildings” (Annex 61, 2016).

For building applications, special attention will be paid to:

- thermal performance such as U-value, including thermal bridge,
- heat, air and moisture transfer air & water tightness,

- high temperature & low temperature (condensation & freezing risk), especially for façade applications.

#### **SUBTASK 4: Sustainability – LCC, LCA, EE – Risk & Benefit**

Subtask Leader: Chalmers University (Holger Wallbaum)

Data will be provided by manufacturers.

This subtask will be separated in two actions:

- Action 4A: Life Cycle Assessment (LCA), including Embodied Energy (EE),
- Action 4B: Life Cycle Cost Analysis (LCC).

The goal of this task is to assess the overall sustainability of SIMs through the evaluation of LCA, and LCC of superinsulation materials over the entire life cycle (production, use and end-of-life).

Life Cycle Inventories for the production step will be established relying on input from material and component producers. The in-use phase will be modelled in various climatic contexts and several building types, considering results from Task 2 and 3 alongside taking into account the fact that SIMs are expected to allow larger living or commercially usable areas in a building whilst achieving lower or equivalent U-values. Current and potential future end-of-life treatment processes will be analysed, and corresponding inventories established.

Inventories for all three phases will not only include material and energy flows but also economic flows, thus allowing evaluating the environmental profile of the materials, components and systems at the same time with costs over the whole life cycle.

This task will be carried out in conjunction with the Annex 57 “Evaluation of Embodied Energy & Carbon Dioxide Emissions for Building Construction” (Annex 57, 2016).

### **1.3 Deliverables & Target Audience**

The deliverables from Annex 65 will be a well-defined set of documentation, as:

- a report on the state of the art on SIM, available on the market, as well as components and systems integrating SIM,
- recommendations on how to characterise SIM,
- recommendations on how to perform reliable testing of components and building integrating SIM,
- guideline of appropriate applications and installation methods,
- a synthesis report and a summary for larger dissemination.

The target audience and Annex beneficiaries are:

- ISO, CEN, UEATc, EOTA,
- the building research community,
- the supply chain: material, component and system,
- engineering offices and consultants,
- building contractors with an interest in high performance systems.

The specific deliverables and related subtask are listed Table 2:

Table 2: The specific deliverables and related subtasks.

<b>Ref.</b>	<b>Deliverables</b>	<b>Related subtask</b>	<b>Target Audience</b>
<i>D1</i>	<i>State of the Art and Case Studies report</i>	ST1	Supply Chain
<i>D2</i>	<i>Scientific Information for Standardisation Bodies dealing with Hygro-Thermo-Mechanical Properties &amp; Ageing report</i>	ST2	CEN, ISO, EOTA, UEATc, Testing laboratories Materials manufacturers
<i>D3</i>	<i>Guidelines for Design, Installation &amp; Inspection with a special focus on Retrofitting</i>	ST3	Designers, Engineers, Contractors, Builders
<i>D4</i>	<i>Report on Sustainability Aspect (LCC, LCA, EE – Risk &amp; Benefit)</i>	ST4	Engineers & Designers

Table 3 depicts the foreseen outreach activities with corresponding target groups.

Table 3: The foreseen outreach activities with corresponding target groups.

	<b>Outreach Activities</b>	<b>Target Group</b>
01	Internet Site & Annex Newsletter	Building Research Community IEA-EBC program
02	Network of Excellence on Measurement Methods	Building Industry & Research Community
03	International Workshops	Building Industry Stakeholders

## 2 Super-Insulating Materials

### 2.1 Description of SIM

In general, heat transfer forced by a temperature gradient may be separated to three different physical heat transfer mechanisms:

- convection, a transport mechanism which is related to the transport of gases or liquids,
- conduction, the energy transfer between neighbouring atoms or molecules in the solid, liquid or gaseous phase, and
- radiation, infrared radiative heat transfer, a mechanism which is not related to the presence of matter at all.

First task of any thermal insulation material at room temperature is to suppress convection, the most efficient heat transfer mechanism. Second task is to attenuate radiative heat transfer. As the thermal conduction of gases is much smaller than that of liquids and solids thermal insulation materials usually are highly porous. Optimisation of air-filled thermal insulation materials balances between radiative heat transfer and thermal conduction via the solid skeleton. Nevertheless, the conductivity of the gas in the hollow spaces is the dominant heat transfer path (see Figure 2). Thus, further improvements are achieved by:

1. modification of the gas - heavy gases have a lower conductivity than air - e.g. in closed-cells polyurethane (PU) foam with blowing agent,
2. reducing the size of the hollow spaces down to the mean free path of the gas molecules in the order of about 100 nm (at 25°C, atmospheric pressure), so that the heat transfer of the gas molecules is hindered by numerous collisions with the solid structure (nano-structured aerogels or fumed silica), or
3. removing the gas by evacuation. Unlike cylindrical vessels like thermos flasks, in flat evacuated elements, a filler material is necessary to bear the external atmospheric pressure. The so-called vacuum insulation panels or VIPs thus in principle are composed by an envelope and a filler or core material.

The scope of the present work covers two different types of so-called super insulation materials (SIM):

- Advanced porous materials (APM), where gaseous heat transfer is hindered significantly by the fine structure in the sub-micrometre range (see the third group in Figure 2) and
- Vacuum insulation panels (VIP), where contribution of gaseous conductivity to the total heat transfer is suppressed by evacuation (see the fourth group in Figure 2).

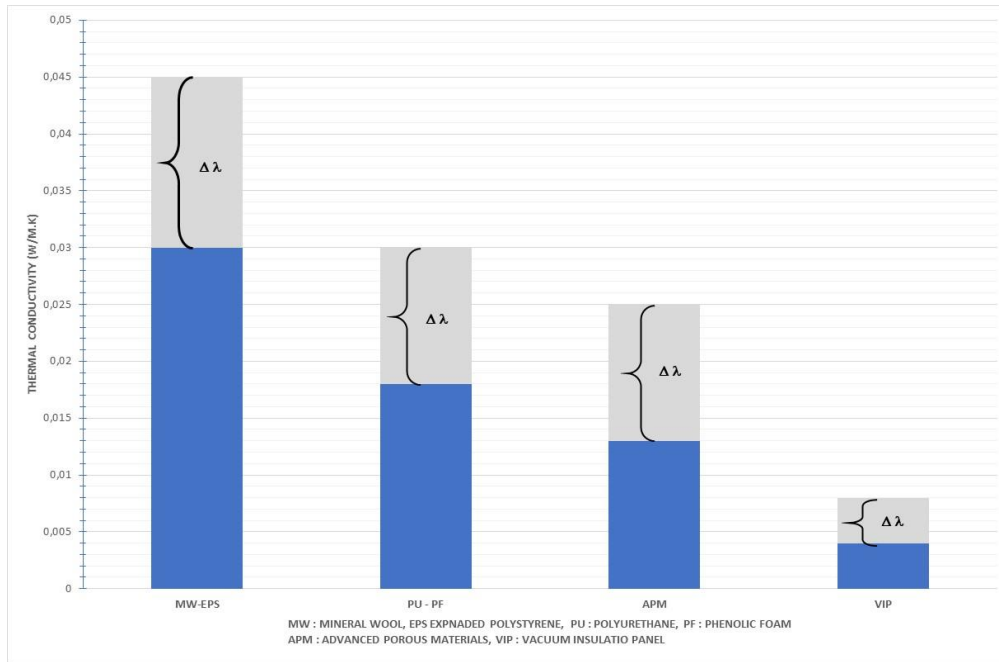


Figure 1: Comparison of the thermal conductivity of different thermal insulation materials used for buildings. The blue bar indicates the spread of different products commercially available.

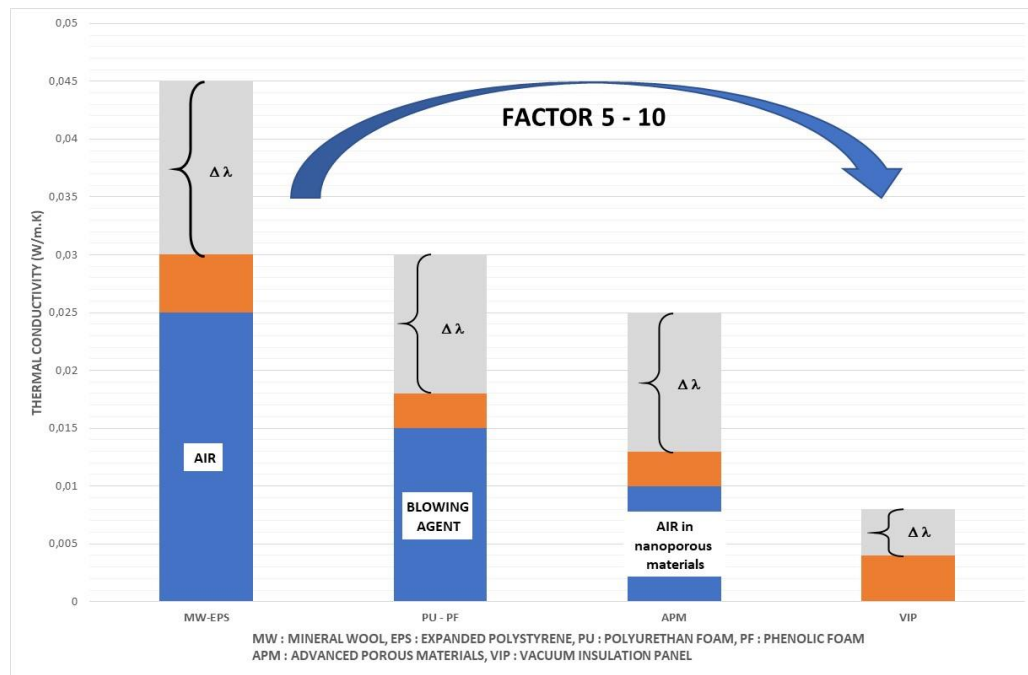


Figure 2: As Figure 1. Additionally, the yellow bar indicates the contribution of the gas to the total heat transfer. It becomes obvious, that significant reductions in the total heat transfer are related to the gas (Heinemann, 2013).

For advanced porous materials (APM) one might distinguish between

- porous silica e.g. based on fumed silica and
- aerogels.

Porous silicas are produced e.g. in flame process (fumed silica); aerogels are gained by a sol-gel process.

The total thermal conductivity of APM is about half of that of conventional insulation materials. Handling and workmanship could be like conventional insulation materials. Therefore, they can be cut and adapted to the needs on-site.

For vacuum insulation panels (VIP) you might distinguish between:

- different core materials: fumed silica, glass fibre, PU, EPS, others;
- different envelopes: metallised film, aluminium laminate, stainless steel, glass, or combinations;
- with or without a getter and/or a desiccant.

The total thermal conductivity of these VIP is about a fifth to one-tenth of that of conventional insulation. Handling and workmanship is quite like windows or façade elements. VIP cannot be cut without losing the benefit of the vacuum. Thus, an exact planning is required to fit to the geometrical sizes of the application. Either standard sizes may be used or special sized and/or shaped VIP have to be custom-made. Staggered double layer pattern could be used to reduce the edge thermal bridge effects. Sensitivity against puncturing of the envelope and increased heat transfer at the edges are characteristics common for façade elements but very unusual for standard insulation products used for buildings.

Some historical review was given by Fricke and Emmerling (1992) for aerogels, and Fricke et al. (2008) for VIP. One of the first publications on aerogels and the relation between heat conductivity and structure in silica aerogel is from Kistler (1932) and (1935). A systematic study on the heat transfer and the contribution of the different paths was given by Kaganer in 1966, translated from Russian to English by Israel Program for Scientific Translation in (1969).

## 2.2 Some basic physics on heat transfer in thermal insulation materials

A thermal insulation material must be optimised with respect to the gaseous thermal conduction  $\lambda_G$ , the solid thermal conduction  $\lambda_S$  and the radiative thermal conduction  $\lambda_R$ , all three of which add up to the total thermal conductivity  $\lambda$ . In addition, a coupling term  $\lambda_C$  must be included;

$$\lambda = \lambda_G + \lambda_S + \lambda_R + \lambda_C . \quad (1)$$

$\lambda_C$  is negligible for foams with non-broken structure. Contrariwise, it can be considerable at elevated gas pressures, e.g., 0.020 to 0.030 W/(m K) for powders consisting of hard grains (see Fricke et al. (2006), Figure 2, examples, perlite and diatomite). The coupling

term becomes noticeable, when – upon an increase of the gas pressure – the gas molecules thermally short the contact resistances between the grains.

The gas conductivity  $\lambda_G$  varies with the gas pressure  $p_G$  according to (Kaganer, 1969)

$$\lambda_G = \frac{\lambda_{G0}}{1 + 2\beta Kn} = \frac{\lambda_{G0}}{1 + p_{1/2}/p_G} \quad (2)$$

$\lambda_{G0} = 0.026$  W/(m K) is the gaseous conductivity of free still air at 300 K,  $\beta \approx 1.6$  for air,  $Kn = l/\Phi$  is the Knudsen number (where  $l$  is the mean free path of the gas molecules and  $\Phi$  is the pore width of the porous insulant).  $p_{1/2}$  is the gas pressure at which the gaseous thermal conductivity is equal to  $\lambda_{G0}/2$ . According to equation (2), we get for air,

$$p_{1/2} \approx 230 \text{ mbar}/(\Phi/\mu\text{m}). \quad (3)$$

From this equation we recognise, that for nano-structured materials with  $\Phi \approx 200$  nm, one gets  $p_{1/2} \approx 1000$  mbar. Moreover, if the gas pressure is reduced to below 10 mbar, the gaseous conductivity is negligible. For coarser materials with  $\Phi \approx 20$   $\mu\text{m}$ , the gaseous conductivity is fully developed at 1 bar and evacuation to about 0.1 mbar is required, in order to suppress gaseous conduction.

The solid conductivity  $\lambda_S$  is the smaller, the more thermal resistances are built into the insulating material, i.e., the finer structured the material is. “Nano-materials” are superior in this respect, as they resemble fractals, which interrupt the heat flow on the nanometre-level, while perlite and diatomite consist of rather coarse, well conducting grains. The solid conductivity scales with the density  $\rho$  of the material;

$$\lambda_S \propto \rho^\alpha, \quad (4)$$

where  $\alpha \approx 1$  for foams and  $\alpha \approx 1.5 \dots 2$  for materials such as aerogels or fumed silica. The solid conductivity also depends on the external pressure load onto the material; a quantitative description is difficult, as most materials show a hysteresis behaviour with an increase of the solid conduction with the increase of external compressive load. Typical values for pressure loaded fibres are  $\lambda_S \approx 0.001 \dots 0.003$  W/(m K), for powders,  $\lambda_S \approx 0.003 \dots 0.010$  W/(m K) and for pressure sustaining foams,  $\lambda_S \approx 0.005$  W/(m K).

In order to reduce the radiative thermal transport at a given temperature, absorbing and scattering particles have to be integrated into the insulating material. As silica is a weak absorber in the near infrared, an opacifier, e.g., SiC must be added. Quantitatively the radiative thermal conductivity is described by (Fricke, 1993).

$$\lambda_R = \frac{16 n^2 \sigma T_R^3}{3 E(T_R)} \quad (5)$$

Here  $n$  is the index of refraction, which can be approximated by  $n \approx 1$  for low-density materials.  $\sigma = 5.67 \cdot 10^{-8}$  W/(m<sup>2</sup> K<sup>4</sup>) is the Stefan-Boltzmann constant, and  $T_R$  is an average temperature within the insulant;

$$T_R^3 = (T_1 + T_2) \cdot (T_1^2 + T_2^2)/4. \quad (6)$$

$T_1$  and  $T_2$  are the temperatures of the surfaces.  $E(T_R)$  is the extinction coefficient of the insulating material, which is the reciprocal of the mean free path  $l_{ph}$  of the thermal photons. It is correlated with the density  $\rho$  and the mass specific extinction  $e(T_R)$  as follows:

$$E(T_R) = e(T_R) \cdot \rho = 1/l_{ph} \quad (7)$$

For opacified silica kernels, e.g. one has  $l_{ph} \approx 100 \mu\text{m}$ , which means that a typical board with a thickness of 2 cm are infrared-optically thick.  $e(T_R)$  can be calculated from the spectral mass specific extinction  $e(\lambda)$ , which is derived from infrared-optical extinction measurements within the wavelength range  $\lambda = 2 \dots 40 \mu\text{m}$ . By properly averaging  $e(\lambda)$  over the diffusing thermal spectrum at  $T_R$  ("Rosseland" average),  $e(T_R)$  is obtained.

According to equation (5), typical radiative conductivities e.g. of an opacified silica kernel at  $T = 300 \text{ K}$ , with a mass specific extinction  $e \approx 50 \dots 60 \text{ m}^2/\text{kg}$  and a density  $\rho \approx 150 \text{ kg/m}^3$  are  $\lambda_R \approx 0.001 \text{ W}/(\text{m K})$ .

To wrap up the details in this section, one can expect total thermal conductivities of about  $0.004 \text{ W}/(\text{m K})$  for dried and evacuated opacified silica kernels, with contributions of  $0.003 \text{ W}/(\text{m K})$  from solid conduction and  $0.001 \text{ W}/(\text{m K})$  from radiative transport.

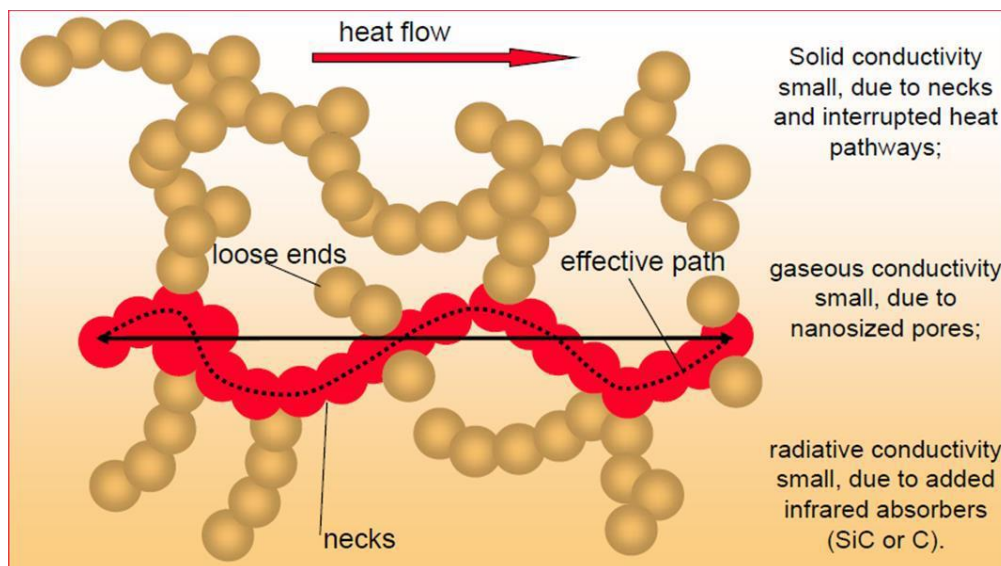


Figure 3: Sketch of the three heat transfer paths in nano-structured aerogels or fumed silica (Fricke, 2005).



The temperature dependence of the total thermal conductivity results from the temperature dependences of all the three heat transfer paths, solid conduction, gaseous conduction and IR radiative heat transfer. For all these, the thermal conduction typically increases with temperature. However, different dependences must be considered due to the different transport mechanisms.

For solid matrix materials used in typical insulation materials for building applications (e.g. glass fibres or organic materials) within the typical temperature range of the application the temperature increase of the solid conduction is only weakly pronounced.

$$\lambda_S(T) \approx \text{const} . \quad (8)$$

For the infrared radiative heat transfer a principle strong dependence results from Stefan-Boltzmann-law. The radiative thermal conduction  $\lambda_R$  at least varies with the third power of  $T_R$  (see equation (5)).

$$\lambda_R(T) \propto T_R^3 . \quad (9)$$

The thermal conduction of a free still gas, without convection and not limited by small pores, typically varies with the square root of the absolute temperature.

$$\lambda_{G,0}(T) \propto \sqrt{T} . \quad (10)$$

The total heat transfer in conventional insulation materials for buildings is dominated by the gaseous contribution (see Figure 2). Thus, its temperature dependence also is dominated by the temperature dependence of the gaseous thermal conduction.

The situation changes if the gaseous heat transfer is reduced by enhanced collisions of the gas particles with structural elements for small pores in the sub-micrometre range. The mean free path of gas molecules typically increases linearly with absolute temperature. For this situation two temperature effects are, more or less, compensating each other. For ideal gases equation (2) may be written as:

$$\lambda_G(T) = \frac{\lambda_{G0}(T)}{1 + 2\beta Kn(T)} = \frac{\lambda_{G0}(T)}{1 + 2\beta \frac{l(T)}{\phi}} , \quad (11)$$

$$\text{with } \lambda_{G,0}(T) \propto \sqrt{T} \text{ and } l(T) \propto T .$$

Thus for advanced porous materials the relative increase of the total thermal conductivity with temperature is less pronounced compared to conventional thermal insulation materials.

For vacuum insulation panels the increase with temperature typically is dominated by the increase of the IR radiative contribution.

## 2.3 Thermal performance of SIM

In most building applications the main purpose of thermal insulation material, component or system is to reduce the heat flux driven by a temperature gradient and thus the energy which is necessary to keep the inside temperature on a desired level. For homogeneous materials with no ageing effects, the characterising property is the thermal conductivity  $\lambda$ . The heat transfer is calculated by:

$$Q = \frac{\lambda}{d} A \Delta T \quad (12)$$

where

$Q$	heat flux in W,
$\lambda$	thermal conductivity in W/(m K),
$d$	the thickness in m,
$A$	the considered area of the element or section of a wall m <sup>2</sup> and
$\Delta T$	the temperature difference across the considered element in K.

The quotient  $U = \frac{\lambda}{d}$  is the material heat transfer coefficient (U-value), which describes the specific insulation property of the insulation layer. For the full U-value the transition resistances between the different material (e.g. also air) layers must be added. Especially in North America the thermal resistance  $R$ , which is the reciprocal of the U-value is commonly used. The concept of using U-values is advantageous when the insulation performance e.g. of a building envelope with different sections (windows, different opaque walls) is considered. Then U-values times the corresponding sizes of areas must be summed up. On the other hand, the use of R-values is advantageous when several layers of different materials or elements are serial-connected. Then the overall performance is described by the sum of the resistances.

Due to the very low thermal conductivity ( $\lambda$ ) (12) of SIM, the  $d$  value can be reduced while reaching a similar U-value compared to traditional insulation materials. This aspect is of great interest for special applications such indoor insulation (space saving), terraces and thermal bridges. The integration in appliances can also greatly improve their performances (refrigerators, boxes and containers for transportation ...)

In practice the building envelope is seldom composed by undisturbed insulation layers. Mechanical fasteners, load-bearing supports, window frames and so on, which typically have higher thermal conductivities or U-values, and smaller R-values, yield in an increase of the heat transfer. Thus, the overall thermal insulation performance is somewhat less (Schwab et al., 2005e).

If one considers the application of super-insulating materials (SIM) the influence of thermal bridges on the overall performance becomes much more significant in relation to total heat flow, the more, the better the insulation property of the insulation material is. This in principle holds for both types of SIM. However, it might be especially pronounced

for vacuum insulation panels (VIP) with a thermal conductivity a factor of 2 to 5 less compared to the advanced porous materials (APM). While APMs typically might be used as homogeneous layers, VIPs are elements consisting of a filler material and a high barrier laminate. Depending on the combination of filler material and the kind of the envelope, the influence of the envelope might increase the overall heat flow of such elements itself by several hundred percent. In addition, the joint of two adjacent VIPs might result in significant thermal bridges.

Thus, for the application of SIMs the influence of thermal bridges must be considered very carefully.

Another aspect to be considered is the possible variation of the thermal performance at long-term perspective. For polyurethane foams filled with heavy gases e.g. an exchange of gases inside and outside yields an increase of thermal conductivity with time (beside climatic conditions depending on thickness and possible barrier layers on the top). For some mineral fibres, a degradation of the thermal performance is observed for the case of water vapour accumulation.

Also, with respect to SIM the durability and possible long-term effects must be scrutinised. For VIPs, even non-professionals ask how long the “vacuum” is maintained within the panels. Indeed, the requirements on the tightness of the envelope are much higher compared to most evacuated products. Without re-evacuation the internal gas pressure should remain on the required level for several decades of use. Additionally, the impact of moisture, freeze/thaw, UV-radiation, solvents and so on must be considered. This also holds for APMs where for example the positive effect of “hydrophobisation” might be reduced with time.

Thus, in the following sections, thermal bridging effects and the long-term behaviour are considered in detail.

## 2.4 Enhanced influence of thermal bridging

### 2.4.1 General

VIPs are made of materials that are geometrically and thermally very different. The barrier complex is composed of several layers of very thin materials with different conductivity values, while the core material is much thicker (1 cm or more) and much less thermally conductive: the overall barrier complex conductivity is at least two orders of magnitude greater than the core conductivity.

This large difference between materials’ thermal characteristics in VIP involves an additional thermal flow at the edges, from the warm side to the cold side. Resulting thermal bridges have to be considered when studying and optimizing VIPs’ global performance, i.e. thermal losses through component and condensation risks.

### 2.4.1.1 Influences on thermal bridging effect

The barrier foils are either aluminium laminated films (ultra-barrier laminates), metallised plastic films (high barrier laminates) or a combination of both (hybrid envelopes). The laminates differ in their permeability values for water vapour and air. As both laminate types make use of aluminium as an inorganic barrier material (thermal conductivity aluminium  $\lambda \approx 200 \text{ W/m.K}$ ) the envelopes and sealing layers are an inevitable thermal bridge at the edges of the panels. The severity of the thermal bridging effect is strongly connected to the thickness and number of the aluminium layer(s) in the laminates, the edge design of the panels (single or multilayer edge design), the gap width between two panels installed next to each other and the filling material of that joint (Sprenghard & Spitzner, 2011a; 2011b). Further influence comes from the use of cover layers on the panel surfaces mostly used to protect the panels during installation and use. Layers made of wood, massive plastics, rubber, metal sheets and similar materials lead to an increase of the thermal bridging effects at the panel edges due to cross conduction in the cover layers towards the panel edge (Sprenghard & Holm, 2014). A slight decrease of thermal bridging effect can be achieved by use of insulating material cover layers such as PU-foam, polystyrene or similar materials of comparatively low thermal conductivity. These materials function as additional thermal resistance and are able to reduce the cross conduction (Sprenghard & Holm, 2013).

Aluminium laminated films (ultra-barrier properties) have aluminium layers from 6 to 12  $\mu\text{m}$ , where metallised plastic films have two or more layers of evaporated aluminium in the thickness range of 30 nm to 100 nm each on PET, special PET or EVOH substrates. The thermal bridging effect (linear thermal transmittance  $\psi$ ) is therefore much higher for the aluminium-laminated films compared to the metallised plastic films.

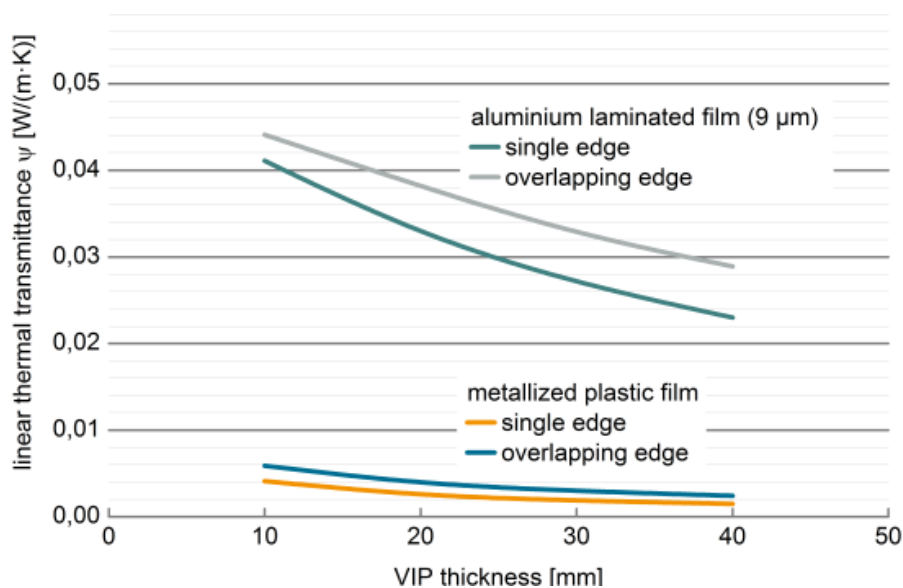


Figure 4: Comparison of linear thermal transmittance calculated for aluminium-laminated films (9  $\mu\text{m}$  AL) and metallised plastics films (3 x 60 nm AL) for two edge designs (Sprenghard & Holm, 2014).

### **2.4.1.2 Influences on different scales (product and building component scale)**

To determine the over-all thermal performance of VIPs for building applications it is inevitable to take the thermal bridging effects of the panel edges into account. The magnitude of the thermal bridging effect at the panel edge is decisive for the total performance of the panel. The total performance is also depending on the perimeter to area ratio, where small panels perform significantly worse than large panels. Additional thermal bridging effects result from the application and from mounting and fixing (Quenard & Sallee, 2005; Schwab et al., 2005e). These effects influence the thermal transmittance of constructions containing VIPs. To date the scientific community distinguishes between various effects that must be added to the panel's performance ("as placed on the market") (in the following mentioned as "panels scale") and effects, which result from the application where the panel is used in (mentioned as "building components scale"). Thermal bridging effects are usually calculated using numerical simulations according to ISO 10211, but they can be measured as well using the guarded hot plate (GHP) or heat flow meter (HFM) technique on the joint of two panels (according to EN 12667 with adjustments).

### **2.4.2 Numerical determination of the overall performance**

In the following subsections first the thermal performance on the scale of panels, i.e. e.g. vacuum insulation panels themselves or APM panels, then the performance on the scale of building components such as façade elements or wall sections, is described.

#### **2.4.2.1 Calculation of thermal bridges on the panels scale**

Global performance, including thermal bridges, of VIPs can be determined.

Conventional insulating materials are sold by their thermal resistance or their thermal conductivity stated in product data sheets or technical approvals. To be comparable with these materials, for VIP manufacturers and architects it is helpful to state and use a single thermal performance value for these products. Therefore, equivalent thermal resistance for the elements or equivalent thermal conductivity for the insulating material is derived backwards from thermal transmittance and the thickness of the panels using various inputs.  $\lambda_{\text{eff}}$  can be derived from  $U_{\text{eff}}$  obtained by 2-/3-dimensional numerical simulations of all thermal bridging effects including additional calculations for various panel sizes.

The overall thermal transmittance (or effective thermal transmittance) for a VIP on panels scale can be calculated as follows (equation (13)). For a VIP on panels scale no point thermal transmittance is considered:

$$U_{\text{eff.-panel}} = U_0 + \Sigma(\psi_i l_i) / A_{\text{panel}} \quad (13)$$

where

$U_0$	thermal transmittance at the centre of panel without thermal bridges (one-dimensional) in $W/(m^2 K)$ ,
$\psi$	linear thermal transmittance resulting from the barrier foil around the panel edges in $W/(m K)$ ,
$l$	length of the rims in m and
$A_{panel}$	area of the panel in $m^2$ .

For VIP studies at any scale, a detailed model taking into account every single layer in the barrier film as well as the seam geometry would be an ideal option regarding accuracy goals in terms of describing heat transfer phenomena (Wakili et al., 2004). However, this kind of approach is very time-consuming, and more simplified modelling methods have been developed by Tenpierik et al. (2008), already published in (Binz et al., 2005).

These modelling methods permit to do parametric studies on VIP properties, such as barrier thickness and thermal properties, heat transmission coefficients at boundary surfaces, core material properties, and VIP thickness and size.

#### 2.4.2.2 Calculations of thermal bridges on the building component scale

If one wants to calculate the overall thermal performance of a construction, the 3-dimensional effects of mounting and fixing need to be considered both by their point thermal transmittance  $\chi$  and by their number  $n$ . Especially if insulation layer penetrating mechanical fasteners are used, also 3-dimensional effects are necessary, as their effect easily exceeds the 3% criterion in ISO 6946. In an analogous way as described in (13) the total heat flow is then calculated by these numbers and the effective U-value  $U_{eff}$  can be derived from panel size and (hypothetic) temperature difference (this can be set to 1 K in  $Q_{eff}$  and  $U_{eff}$  calculations).

$$U_{eff} = \frac{Q_{eff}}{A_{panel} \Delta\vartheta} \quad (14)$$

$$Q_{eff} = \Delta\vartheta (U_{eff,panel} A_{panel} + \sum \psi_i l_i + \sum \chi_i n_i) \quad (15)$$

where

$U_{eff}$	effective U-value of whole element in $W/(m^2 \cdot K)$ ,
$Q_{eff}$	total Heat flux through element in W,
$A_{panel}$	area of element in $m^2$ ,
$\Delta\vartheta$	temperature difference in K,
$U_{eff,panel}$	U-value of panel according to explanations in chapter 2.4.2.1 in $W/(m^2 \cdot K)$ ,

- $\psi_i$  linear thermal transmittance (e.g. for the gap in between assembled panels) in  $W/(m \cdot K)$ ,
- $\chi_i$  point thermal transmittance (e.g. for mechanical fasteners) in  $W/K$  and
- $l, n$  length of the joints in m; number of anchors (dimensionless).

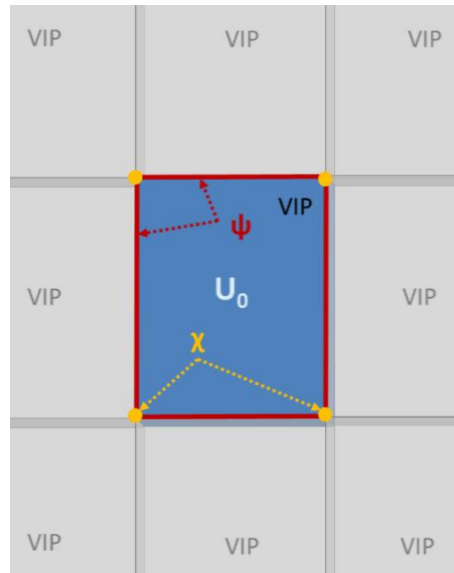


Figure 5: Overall thermal transmittance of assembled VIPs on building components scale.

The aim is to forecast the behaviour over time of materials and components by means of heat and moisture transfer calculations using specific software tools. The main results are moisture contents, temperature and humidity profiles and, in case of whole component analysis, transient U-value. This calculation method can be useful for the assessment of the hygrothermal risks over time and the determination of critical events.

The simulation can be carried out for different initial conditions and different boundaries conditions in 1-dimension or 2-dimension.

The hygrothermal performance of a wall assembly is a balance of the simultaneous normal heat flow by the three way of transport (conduction, convection and radiation), moisture flow by vapour diffusion, convection and liquid transport, and finally the airflows produced by natural or mechanical forces.

Several hygrothermal models, with flow equations combined with mass and energy balance, have been developed in the last 20 years by researchers (Annex 24; Annex 41). Among the 57 hygrothermal models in literatures just 14 are associated to software tools, accessible to the public: 1D\_HAM; BSim; Delphin 5; EMPTIED; GLASTA, HygIRC; HAMLab; HAM-tools; IDA-ICE 4.5; MATCH; MOIST 3.0; MOISTURE-EXPERT; UMIDUS and WUFI.

The combined heat and moisture transfer calculation can be carried out for instance for a thermal retrofit case study, in case of inner and outer insulating as well. In specific

cases the simulation should be coupled with in-situ monitoring (i.e. test wall) to validate the assumption made for the materials and the initial conditions in the model.

The method is valid specifically for porous materials, but with the right assumptions, it may also be adapted for other materials such as metallic surfaces (i.e. vapour barriers) and air cavities.

### 2.4.3 Experimental approach to determine the overall thermal performance

The thermal performance at panel scale can be determined as follows. The first step is to measure the thermal conductivity in the centre of panel  $\lambda_{COP}$  in a GHP or HFM apparatus and calculate the thermal transmittance in the undisturbed area  $U_0$ . Then the thermal bridging effects for the barrier foil around the edges of the panels have to be added by their linear thermal transmittance  $\psi$  and their length (see chapter 2.4.2.1).

Direct determination of thermal performance of assemblies is possible by measurement of  $U_{eff}$  in a hot box or by measuring  $R_{eff}$  in a GHP or HFM apparatus.

The differences are obvious: when numerical simulations are used, all effects can be determined separately (e.g. different edge designs, gasket strips or adhesive tapes). When using hot box measurements, 2- and 3-dimensional effects can be considered, but only in total. It is not possible to determine single effects, but the thermal performance can be measured directly. When using GHP or HFM measurements, the same limitations as for hot box measurements apply and additionally these measurements can only be used to measure 2-dimensional effects.

$$\lambda_{eff} = \frac{d_{panel}}{\frac{1}{U_{eff}} - R_s} \quad \text{or} \quad \lambda_{eff} = \frac{d_{panel}}{R_{eff}} \quad (16)$$

where

- $\lambda_{eff}$  Equivalent thermal conductivity for a VIP including 2- and 3-dimensional thermal bridging effects in W/(m·K),
- $d_{panel}$  thickness of the VIP in m
- $R_s$  Sum of internal and external thermal resistances at the surfaces of the panel in m<sup>2</sup>·K/W
- $R_{eff}$  Thermal resistance of the VIP including thermal bridges – taken from a measurement of a joint assembly in m<sup>2</sup>·K/W

If  $U_{eff}$  is determined by measurement of a joint assembly in a GHP or a HFM apparatus from  $R_{eff}$  the cold-side and warm-side surface resistances are negligible. The term  $R_s$  in the equation can be omitted.



## 2.5 Long Term Performance - Ageing Mechanisms

### 2.5.1 Introduction

The exposure and service conditions of any material, product, system and component could lead to temporary or permanent degradations affecting one or more of their properties. Thermal insulation materials are no different in this respect. Temporary degradation can be due to changing environmental conditions and usually cyclic with environment variables. For example, closed cell foam insulation with blowing agent will change its thermal conductivity or resistivity with the temperature variation (Drouin et al., 2012). Permanent degradation can be short-term or long-term. The terms *short* and *long* are relative to the expected lifetime. Most of the time the mechanisms involved with short or long term are different and *ageing* is the term used only for the set of slow irreversible modifications affecting the material, the product or the system over time (i.e. long-term) in given conditions. SIMs exhibit these two kinds of degradation: ageing and short-term degradation or failures. Both need to be known: the first one for long-term performance assessment and the second to avoid conditions inducing these fast degradations.

Naturally, many properties of SIMs, such as mechanical (compression, tensile, creep), dimensional stability, thermal, hygric (water sorption and permeation), acoustics, aesthetics, optical (visible and infrared) etc., could have significant implications on their end use performance. However, the main one for the SIMs is thermal and it is invariably, linked with hygric properties. For this chapter only the parameters affecting the thermal conductivity are considered; as summarised in Table 4 according to the parallel flow model (Kaganer, 1969) which distinguishes the contributions of the internal infrared radiation, the solid phase conduction and the gas phase conduction (see equation (1)).

Specific ageing and/or degradation may occur at the barrier envelope level of VIPs. However, as we can see in Table 4 there could be a great similitude between VIP and APM depending on the core material. Indeed, nano-structured (mainly mesoporous) materials show the same tendencies to i) sorption, and ii) textural evolution. These two tendencies are both due to the huge specific area ( $A_{spec}$ ) of such materials (160 – 1000 m<sup>2</sup>/g) as sorption capacity is proportional to  $A_{spec}$  in the Langmuir and Henry domains, and as the high internal energy  $E_S$  coming from the surface is a powerful engine to the decrease of the surface:

$$E_S = A \gamma_{sv} = \frac{3 M}{r \rho_s} \gamma_{sv} \quad (17)$$

with

$\gamma_{sv}$	surface specific energy solid – vapour in J/m <sup>2</sup> ,
$M$	molar mass,
$r$	particle radius.

Table 4: Summary of degradation mechanisms where the significance on the thermal conductivity has to be considered.

Thermal/Hygric properties	Mechanisms	VIP	APM
Radiative conductivity	IR-optical modification due to sorption	•	•
Solid conductivity	Water adsorption Physisorption	•	•
	Chemisorption	•	•
	Chemical bonds hydrolysis	•	•
Solid conductivity	VOC adsorption Weight gain		•
	Interaction with water		•
Gaseous conductivity	Other chemical & physical hazards (condensation, freezing)		•
	Pressure increase	•	
Gaseous conductivity	Pores sizes evolution	•	•
	Permeation, sorption, diffusion	•	
Permeation through the barrier	Envelope ageing and/or degradation (Corrosion, hydrolysis, delamination)	•	

Thanks to the very small size of the solid particles, the surface energy reaches high values: typically, 5 kJ/mol for silica aerogel. This explains why chemical reaction and not physical foaming fabricate them, and why such materials are instable when exposed to conditions, where their atoms or molecules are mobile. Such conditions could be reached at quite low temperature for inorganic or organic material reacting with water. Finally, nano-structured VIP core and APM exhibit what we call thermo-hygric ageing whose effects are listed hereafter.

### 2.5.2 Evolution of the radiative conductivity

The radiative conductivity (5) could evolve with ageing. The volume extinction coefficient  $K = \sigma_{ext} \cdot \rho$  could be affected by four means: increase of the density, water sorption (physi- and chemi-sorption), VOC adsorption, and hydrolysis of hydrophobant grafting.

If the influence of the surface chemistry of the silica on its optical properties and thus its conductivity is roughly known (Coquard et al., 2013), other influences are mainly not or badly known. This explains why this evolution is neglected despite its significant contribution to the equivalent conductivity of APM.

### 2.5.3 Evolution of the solid conductivity

We propose, to consider the following simple relation to give the solid contribution of adsorbed species:

$$\lambda_s = \lambda_{s0} + B \cdot \tau_w + B' \cdot \tau_{VOC} \quad (18)$$

Where:

- $\lambda_{s0}$ : solid conductivity at dry state,
- $\tau_w$ : core moisture (ratio mass of water/mass of core),
- $\tau_{VOC}$ : mass ratio of VOC.

This allows to distinguish the simple water sorption (section 2.5.3.1), the hygric ageing (section 2.5.3.2) and the VOC adsorption (section 2.5.3.3).

The physisorption and chemisorption of water on silica are described Figure 6. The water physisorbs by hydrogen bonds on polar sites i.e. silanols here represented, or water molecules previously adsorbed). The water chemisorption corresponds to siloxane hydroxylation by one water molecule and formation of two silanols; this reaction is reversible at  $T \geq 190 \pm 10^\circ\text{C}$  (Zhuravlev, 2000).

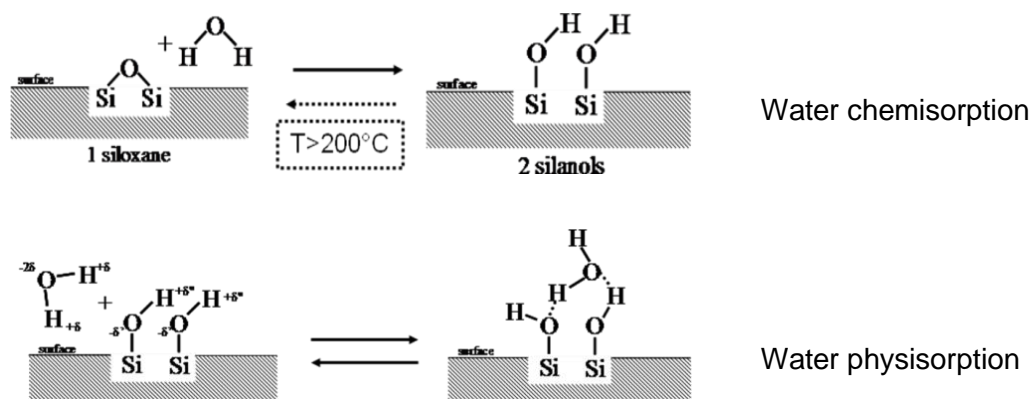


Figure 6: Water adsorption mechanisms (Morel, 2008).

The same type of mechanisms is observed on other materials: physisorption on hydrophilic molecular sites and chemisorption by hydrolysis of weak bonds or by hydration reaction.

#### 2.5.3.1 Simple water adsorption

In that case, only physisorption and condensation occur in a reversible way. The amount of sorbed water  $\tau_w$  is mainly a function of the water activity (relative humidity) given by the sorption isotherm and for some materials also a function of the temperature.

In that case the coefficient  $B$  in equation (18) is often considered constant and the increase of the mass ratio of water induces the increase of the solid conductivity. This is true for the coarser macroporous materials and for those with Henry or Flory-Huggins types of isotherm (in Henry's domain). We can imagine that materials with a very intense Langmuir behaviour and / or with condensation at the highest activities do not show a constant coefficient  $B$ , but there is no evidence in the literature.

### 2.5.3.2 Hygric ageing

In the case of hygric ageing chemisorption occurs in an irreversible way, followed in the reality by physisorption. The higher the temperature and the humidity the higher are the evolutions. Different sub-mechanisms are involved:

- a) Modification of the surface chemistry to a possible increase of the surface hydrophilicity. This parameter is expressed by the ratio  $\psi_{ads}$  of the mass of water at a given activity by the specific area (equation (19)) or by the ratio  $Hp$  of the specific surfaces determined with water and nitrogen (or other non-polar adsorbant). In the silica case the density of silanols,  $nb_{OH}/nm^2$  is often used.

$$\psi_{ads} = \tau_{ads@50\%RH} / A_{BET N_2} \quad (\mu g/m^2) \quad (19)$$

$$Hp = A_{BET W} / A_{BET N_2} \quad (m^2/m^2) \quad (20)$$

- b) Increase of the water thickness, which can be calculated from the sorption isotherms by the Brunauer-Emmett-Teller (BET) or Guggenheim-Andersen-de Boer (GAB) models.
- c) A kind of sintering of the nanoparticles not fully understood but where smoothing and coalescence of particles was highlighted (Yrieix et al., 2014) with two consequences (Figure 7):
1. decrease of the tortuosity of the solid skeleton;
  2. increase of the neck size between particles.

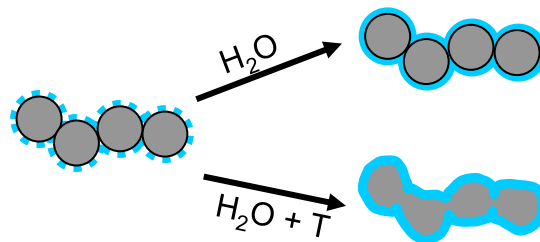


Figure 7: Schematic smoothing and coalescence of primary particles of silica.

The main marker of this evolution is the decrease of the specific area. In a first approximation, this mechanism could be described as an Ostwald ripening process

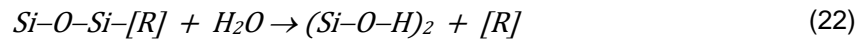
(equation (21)) which explains quite well the higher sensitivity to ageing with the decrease of the size of the particles.

$$S = S_0 \exp\left(\frac{2 \cdot \gamma_{SL} \cdot V_m}{R \cdot T \cdot r}\right) \quad (21)$$

where  $S$ : effective solubility,  $S_0$ : flat surface solubility,  $\gamma_{SL}$ : solid/liquid surface tension,  $V_m$ : molar volume,  $r$ : curvature radius.

This sintering is observed by electronic microscopy, by small angle X-ray diffusion (SAXS), by gas sorption, and indirectly by the stiffening of the matrix.

Another mode of hygric ageing is the hydrolysis of chemical bonds very well known in other applications like polymers, paints, and composites. For the VIPs and APMs considered, the main potentiality is the hydrolysis of the hydrophobant grafting with the following general relationship:



The consequences of such behaviour are manifold:

- a) the hydrophobant release, outgassing in a VIP;
- b) the formation of silanols, so
  1. an easier hydrolysis of siloxane;
  2. an increase of the hydrophilicity;
  3. an increase of the potential micro condensation, which in return boosts the matrix ageing.

To conclude about the hygric ageing, all these modifications of the skeleton lead to the increase of the solid conduction contribution to the conductivity. In equation (18) this results in an increase of the coefficient  $B$  (mainly due to the modification of surface chemistry) and / or an increase of the solid conductivity at dry state  $\lambda_{cs0}$  (mainly due to the textural coarsening).

### 2.5.3.3 VOC adsorption

By definition, this concerns only APMs and not VIPs. In that case, only physisorption occurs in a possibly reversible way.

On one hand the adsorption of matter increases the mass and the density of the material (represented by  $\tau_{VOC}$ , the mass ratio of VOC in equation (18)) leading to an increase of the solid contribution to the conductivity.

On the other hand, VOC are mainly non-polar species, which appreciate to sorb on oleophilic site and due to their large dimensions compared to the distance between hydrophilic sites on the surface, they are able to act as a kind of hydrophobant. This

behaviour has already been observed in nano-structured silica (Morel, 2008) (Morel, 2008) where the hygric ageing was slowed.

In our knowledge, no focused study about the thermal influence of adsorbed VOC exists.

#### **2.5.3.4 Other chemical and physical hazards**

Even if not comprehensive because strongly dependent on the applications we list five reasons of degradations with the consequence of increasing the solid contribution to the conductivity: Condensation and freezing both for VIP and APM, silica – alkali reaction and salts pollution for APM and creep for VIP.

Condensation inside a porous material is enhanced at lower relative humidity by the small pores sizes. As the narrowest pores are filled first, a strong increase of the solid conduction is expected in case of condensation; in nano-structured materials it begins at quite low activity: for example, 50 % RH for silica. After condensation a further decrease of the temperature asks the question of the freezing or not of the water clusters and of the mechanical degradation induced. In our knowledge, no clear study about that exists except for the technological evaluation of silica aerogel-based rendering for external insulation.

For this last kind of material, the questions of the silica-alkali reaction and the salts pollution by diffusion are also on the table.

A creep can occur especially for VIP mechanically loaded. The term “creep” is not fully satisfying because the true mechanism is the re-arrangement of the fibrous or granular media of the core. But this term well characterizes the mechanical behaviour. However, the density of the core can increase with time, typically following a decreasing exponential kinetic. Of course, the increase of the density leads to an increase of the solid conduction. In our experience at the whole conductivity level, this is not compensated by the decrease of the macroporosity.

### **2.5.4 Evolution of the gaseous conductivity**

#### **2.5.4.1 Pressure increase, in VIP**

Of course, the increase of the pressure inside a VIP is well known as a dramatic way to promote the increase of the gaseous conductivity (Equation (2) and Figure 8). The dependence on the nature of the core material is also well known even if the material is often described only by one monomodal pore size (or  $P_{1/2}$ ).

A point that less is known is the relevance of aggregating all the gas incoming in the VIP in a single gas described only by its total pressure. The smaller size of the water molecule compared to the dry air mean molecule (collision diameters respectively  $3.04 \cdot 10^{-10}$  and  $3.52 \cdot 10^{-10}$  m for thermal purpose) plays in the same direction as the lowest conductivity in normal conditions (respectively 0.0182 and 0.025 W/(m K)). As shown in Figure 8 the

gaseous conductivity of water vapour, confined or not, is always lower than the conductivity of air at the same pressure.

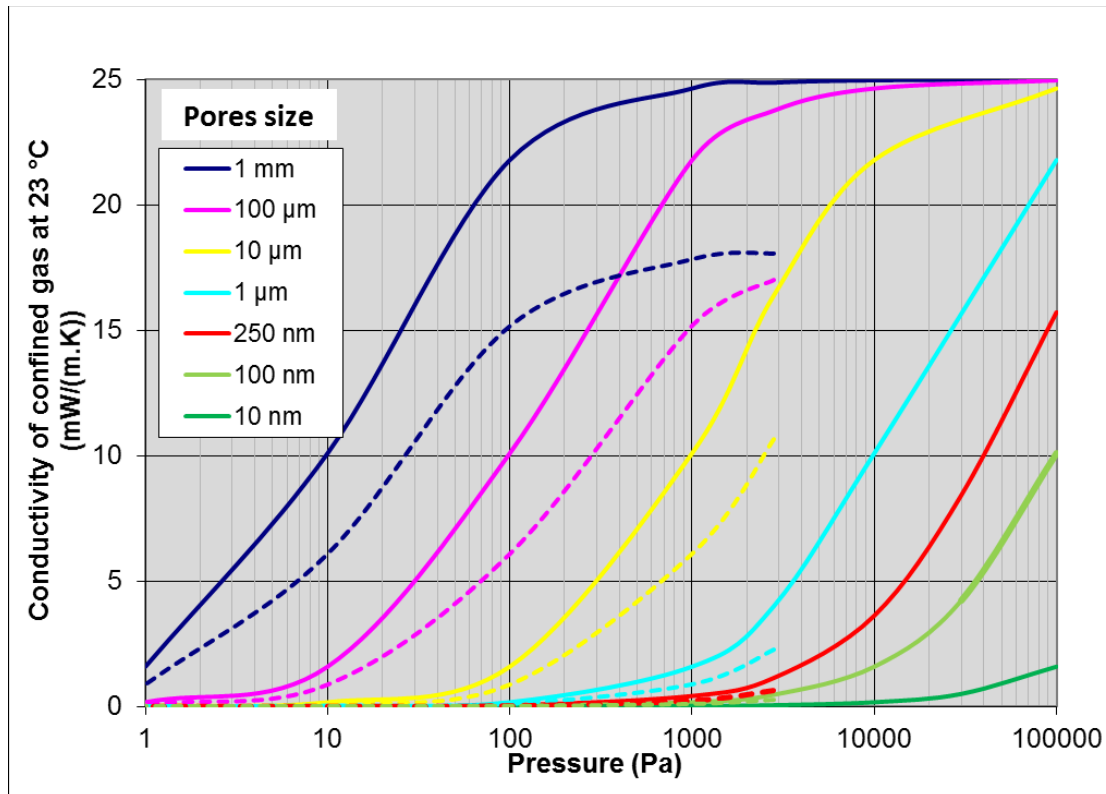


Figure 8: Conductivity of confined gas at 23°C as a function of pressure and pores size (solid lines: dry air; dashed lines: pure water vapour),  $P_{sat} = 2800$  Pa.

Due to the low concentration of water in air at ambient conditions, water has limited effect on the gaseous conductivity in APMs. On the other hand, higher gaseous concentration of water (regardless the mass concentration in the core) could be obtained inside VIPs during ageing, typically 10 to 20% at the end of life. At the end, the overall error will never exceed 5% on the gaseous conduction and 2% on the equivalent conductivity (calculation performed on the silica core reference SIL1 of Annex 39). This theoretical evaluation is consistent with previous experimental observations (Heinemann, 2008). That is why the total pressure is always considered as dry air pressure for the gaseous conduction.

#### 2.5.4.2 Pores sizes evolution

The textural evolutions of the nano-structured materials described in 2.5.3 tend to modify the pore size distribution. Indeed, because they are the more instable the micropores if present first disappear followed by the smaller mesopores (more significant for the gaseous conductivity purpose). The distribution of the aged materials shows a lower small pore porosity and a shift of the main pore size to upper values. Therefore, the

gaseous conductivity increases (APM and VIP quite aged) or the remaining lifetime decreases (VIP) (equation (23)).

Because of these evolutions of the pore size distribution during ageing of nano-structured material (VIP core and APM), a bimodal or multimodal description (equation (23)) is useful to analyse the different contributions to the gaseous conductivity.

$$\lambda_{cg} = \lambda_{cg0} \cdot \sum_i^{PSD} \frac{\theta_i}{1 + \frac{CT}{\phi_i \cdot P}} \quad (23)$$

In a practical way, this means to integrate the Knudsen law over the pore size distribution. The determination of this latter remains very challenging as described in 3.2 and 4.5.

### 2.5.5 Permeation through the barrier

Before the VIP core undergoes the previous evolutions leading to an increase of the gaseous and solid conductivities, atmospheric gases have to come in. The mechanisms are the permeation in nominal or damaged conditions up to the leakage. Therefore, we distinguish:

- the regular ageing of the VIP where no ageing or damaging of the envelope occur;
- the dramatic ageing of the VIP where the ageing of the laminate itself lowers the barrier properties and sometimes leads to the venting of the VIP.

#### 2.5.5.1 Permeation without ageing of the envelope

Permeation is usually described by sorption-diffusion model detailed by Crank and Park (Crank & Park, 1968) for polymers. It is a linear model of mass transfer established for the polymeric homogeneous membranes, where Fick's law is used for the diffusion in the membrane and Henry's law for the solubility and where the permeating gases are considered as perfect i.e. here without interaction between them. The permeance  $\Pi$  in a polymeric membrane is defined as the product of the diffusion coefficient  $D$  and the solubility coefficient  $S$ , divided by the thickness  $x$  (equation (24)):

$$\Pi = \frac{\delta}{x} = \frac{D \cdot S}{x} \quad (24)$$

With the permeability  $\delta = D \cdot S$ . Because both solubility and diffusion are thermally activated, permeability and permeance are also thermal dependent (equation (25)).

$$\delta_{(T)} = \delta_0 \cdot e^{-\frac{Q_\delta}{RT}} = D_0 \cdot e^{-\frac{Q_D}{RT}} \cdot S_0 \cdot e^{-\frac{Q_S}{RT}} \quad (25)$$

With  $Q_\delta$ ,  $Q_D$ , and  $Q_S$  the activation energies of permeability, diffusion, and solubility.

Most of the time diffusion increases with temperature while solubility decrease with a final increase of the permeability dominated by the diffusion.



The behaviour of an ideal layer stacking is given by equation (26):

$$\Pi = \frac{1}{\sum_{j=1}^n \frac{1}{\Pi_j}} \quad j \text{ refers to a single layer.} \quad (26)$$

Note that in equation (26) "layer" should be understood either for virgin polymer film or for metallised polymer film. The metallisations are considered not to be layers within the meaning of this equation. This approach has already been explained by Langowski (2008); it does call for a permeance homogenised across *virgin film + metallisation* which can be accounted by the models of defects (Prins & Hermans, 1959; Hanika, 2004; Langowski, 2008) which considers the metallic deposit as coherent and impermeable. The solubility is a volume parameter; thus, it can be extended to a coated membrane. The diffusion coefficient of the metallised polymer layers is the equivalent diffusion coefficient, controlled by the aluminium layer (barrier function against gas transfer).

If the assumption of Henry's law validity for the most common laminates which use PET, PE, and PP films, is now better documented (Pons et al., 2014), (Dubelley, 2016), the assumption of perfect gas behaviour is more and more subject to doubt (Bouquerel, 2012) and specific studies are in progress: see subtask 2 experimental and modelling.

The manufacturing of the VIP is the origin of damages affecting the barrier: new defects linked to the angles, the edges, the folds (Brunner et al., 2008) and of course of the especial zone of seals. Therefore, the permeance measured on a whole VIP is higher than the one measured on laminate alone.

At the end, each gas has different permeability (diffusion and solubility) through the different polymer layers: for instance,  $\Pi_{air} \ll \Pi_{wv}$  leading to a closer transmission rate thanks to the difference of partial pressure. Therefore, the barrier improvement factor of a given barrier layer (for instance Al foil or metallised Al) is not the same for oxygen, nitrogen and water vapour. An extra difficulty is the plasticizing effect of some sorbed molecules like water in EVOH or PA. In that case, the permeation is not only temperature dependent but also humidity dependent.

### **2.5.5.2 Degradation of the barrier envelope**

If the temperature and / or the humidity exceed values depending on the products (typically  $T \geq 50 \text{ }^\circ\text{C}$ ), different individual degradation mechanisms could occur and thus lead to a rapid loss of barrier properties:

1. Swelling and decrease of the glass transition temperature is reported for PET exposed to moist conditions (Pons et al., 2014).
2. PET, PU (glue), and EVOH are known to be sensitive to hydrolysis. Figure 9 gives the reaction involved for PET.

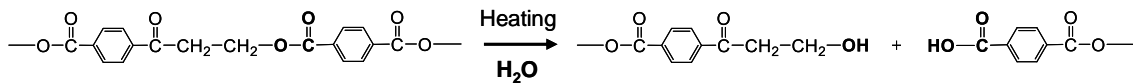


Figure 9: PET hydrolysis mechanism.

F. Dubelley has recently investigated the evidence of this mechanism in the real application of VIP (Dubelley, 2016; Dubelley et al., 2017b). Thermally activated, this mechanism is governed by the water activity and is strongly dependent on the formulation of the polymer

The scission of chains greatly changes the mechanical properties, the polymer becoming brittle, but also releasing carboxylic acid which can promote corrosion.

3. Thermal expansion or restraint could affect many bi-oriented polymers like observed in the packaging industry (Dubelley et al., 2017a).
4. Aluminium corrosion more or less extended has been observed on VIP laminates. Already attributed to halogens in glue and to humidity (Garnier, 2009; Garnier et al., 2011) the aluminium corrosion inside the laminate is studied by LEPMI / LMOPS at Chambéry / France with forthcoming publication in 2017 about the link with the degradation of polymers.

At the macroscopic level of the VIP, these individual mechanisms lead to embrittlement of the laminate, loss of barrier, and to delamination / leakage.

Other damages specific to a given application could exist mainly driven by the environmental conditions:

- UV ageing and embrittlement (glazing applications);
- Alkali attack of polymers or alkali corrosion of aluminium (contact with concrete without protection);
- Solvent or halogen migration from the outside (glue);
- Wearing by friction (transport or thermo-mechanical fatigue);
- ...

### 2.5.6 Practical Approach (for VIP)

Long-term performance of a thermal insulation is indicated by its ability to sustain thermal properties during the expected service life. Usually mentioned as LTTR (long-term thermal resistance) value, it is a very important characteristic of an insulation material and used by the building envelope designers for energy calculations. Building envelope designers in North America and Europe became familiar with the LTTR concept while dealing with ageing of closed-cell foam insulation with captive blowing agents (ASTM C1303 / C1303M-15, 2015; CAN/ULC S770-15, 2015).

Ageing mechanisms of closed-cell foam (Figure 10) and VIP Figure 11 have both similarities and differences. Diffusion of gas and/or vapour is the common phenomenon that governs ageing and LTTR of both closed-cell foam and VIP. In closed-cell foam, the ageing rate is relatively higher at the beginning (i.e. just after production and first few months afterwards) but thereafter ageing rate reduces with time and eventually reaches to a steady state equilibrium with no further ageing due to gas/vapour diffusion. However, for VIP, the ageing rate seems to be about constant, at least for the first 5 to 10 years, and ageing process appears to be a continuous process over a much longer duration of time (Mukhopadhyaya et al., 2011; Mukhopadhyaya et al., 2014a; Mukhopadhyaya et al., 2014b). Moreover, the relative impact of ageing (i.e. percentage of initial thermal resistance) during its service life (25 years or more) is expected to be higher for VIP, compared to closed-cell foam insulation. It is to be noted, even with continuous ageing, due to its extremely high initial R-value (measure of thermal resistance, as used e.g. in North America) VIP for a given thickness provides much higher thermal resistance than conventional thermal insulations (foam, fibre etc.) during its service life. Furthermore, even a totally failed (i.e. no more vacuum) VIP can have higher R-value than traditional insulations used for building envelope construction.

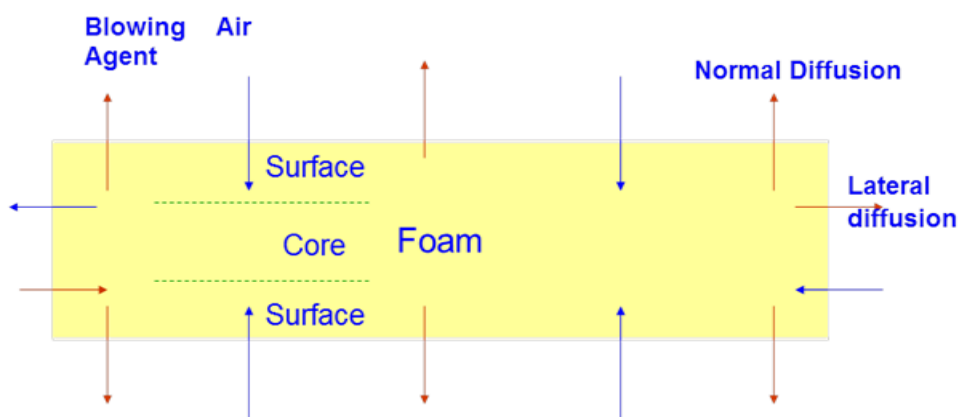


Figure 10: Ageing mechanism – closed cell foam insulation with captive blowing agent.

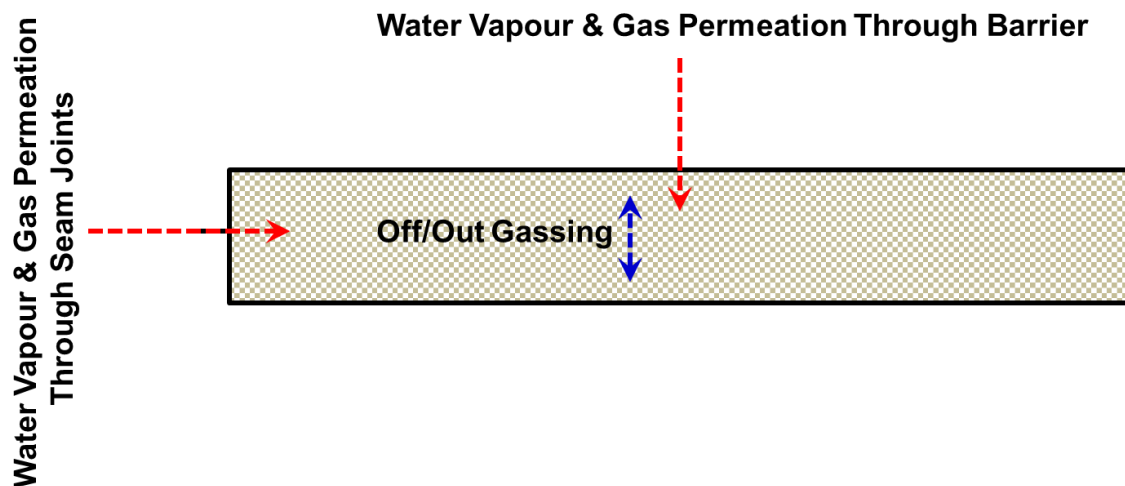


Figure 11: Ageing mechanism – vacuum insulation panel.

## Challenges

Prediction of ageing rate for VIP remains a challenging task. However, a significant amount of theoretical research had been carried out to develop fundamental understandings of the VIP ageing mechanisms (Schwab et al., 2005c; Simmler & Brunner, 2005; Yrieix et al., 2014). In general, theoretical ageing models identify following primary mechanisms for VIP ageing:

- increased thermal conductivity due to gaseous diffusion and resulting internal pore pressure rise,
- increased thermal conductivity due to vapour diffusion and resulting vapour pressure rise,
- increased thermal conductivity due to accumulated moisture content, and
- Increased thermal conductivity due to the textural evolution.

Although there exists some basic understanding on the physics of these ageing mechanisms, there remains a few fundamental and practical challenges for the implementation of these theoretical ageing principles into practical use. They are:

- reliable and repeatable measurement techniques to establish the functional relationships between the thermal conductivity and aforementioned parameters (Pons et al., 2014),
- changes in gas/vapour diffusion properties due to ageing of the facer and seam joint, and
- lack of reliable and controlled field performance data to validate the outputs of the theoretical ageing model.

## **The way forward**

In a way, the aforementioned challenges are not unforeseen in the history of building materials research. New materials when introduced in the building construction industry do not come with long-term field performance data to back its performance claims. Moreover, chemical and physical compositions of many of these building materials keep on changing with the time. These are indeed formidable challenges. One way to address these issues is to conduct accelerated ageing tests in the laboratory. By definition, these are short duration tests, which can clearly demonstrate a VIP's ageing characteristics qualitatively and quantitatively. The only challenge with the results from accelerated ageing tests is to establish the relationship between the accelerated ageing test results and field performance data. This becomes even more complicated when one considers variation of climatic conditions at different geographical locations. However, sustained material research in the laboratory conducted by different research groups and availability of field performance data from various construction types and geographic locations can overcome aforementioned inherent limitation of the accelerated ageing tests. The key factor that makes the difference here is the combination of research expertise, experience and power of diverse field performance data. This is a time tested approach that had worked in the construction industry for many novel construction materials (Chen et al., 2007; ASTM C1303 / C1303M-15, 2015; CAN/ULC S770-15, 2015). Based on this approach, it is possible to develop a comprehensive accelerated ageing test methodology for VIPs and predict the LTTR value of VIP within an acceptable margin of safety. However, it is to be noted that assessment of LTTR of VIP would remain an ongoing process, as global VIP research community members gain more knowledge and generate more information.

In Chapter 4.6 on the state-of-the-art of standardisation, norms, approvals and certifications also the approach how to consider and how to determine long-term performance is outlined.

Subtask 2 of this Annex on “Characterisation of materials & components - Laboratory Scale” especially deals with the practical approach of determination ageing behaviour in context with long-term performance. Accelerated ageing seems to be the most practical approach.

### 3 Advanced Porous Materials

Advanced porous materials (APM) can be described by their morphology. The raw materials consist of a nano-scaled open porous structure with a high-levelled porosity (up to 97%, the most common ones between 90 to 94%) and a solid body built as a network of connected particles and pores in the range of 20 nm. They are known as light materials with density in the range of 50 to 250 kg/m<sup>3</sup>.

APM for thermal superinsulation applications consist primarily of two families:

Firstly, lightweight solids or granular material derived from sol-gel processing, in which the liquid component of the gel has been replaced by air. These may be available as monoliths, granules, fibre reinforced mats, bonded, or packed between to composite sheet.

Secondly, materials based on synthetic amorphous silica packed boards received from hydrophobised pyrogenic (fumed) silicon dioxide.

APMs were first commercially introduced to the building industry in 2003 (Koebel et al., 2012).

Following review articles give an insight to practical applications of APMs in buildings:

- Toward aerogel based thermal superinsulation in buildings: A comprehensive review, (Cuce et al., 2014);
- Glazing systems with silica aerogel for energy savings in buildings, (Buratti & Moretti, 2012);
- Aerogel insulation for building applications: A state-of-the-art review, (Baetens et al., 2011);
- Aerogel-Based Materials for Improving the Building Envelope's Thermal Behavior: A Brief Review with a Focus on a New Aerogel-Based Rendering, (Ibrahim et al., 2015);
- in Chapter 4 "Advanced insulating materials" of the book "Smart Buildings, Advanced Materials and Nanotechnology to improve Energy Efficiency and Environmental Performance", (Casini, 2016)

Details that are more specific are described in:

- Nearly Zero Energy Building Refurbishment, (Torgal et al., 2013);
- Aerogel Plasters for Building Energy Efficiency, (Buratti et al., 2016a) in (Torgal et al., 2013);
- Nanogel Windows for Energy Building Efficiency (Buratti et al., 2016b) in (Torgal et al., 2013);
- Silica Aerogel Composites: Novel Fabrication Methods, (Sachithanadam & Joshi, 2016);
- High-Performance Insulation Materials, (Ebert, 2013) in (Torgal et al., 2013);

### 3.1 Description of APM

Advanced porous materials with superinsulation properties are typically based on materials such as aerogels or synthetic silica.

There are various definitions of aerogels available, depending on the scientific background:

- definition of the International Union of Pure and Applied Chemistry IUPAC: “Aerogel: gel comprised of a microporous solid in which the dispersed phase is a gas. Note: Microporous silica, microporous glass and zeolites are common examples of aerogels.”, (McNaught & Wilkinson, 1997).
- “Aerogel is an open non-fluid colloidal network or polymer network that is expanded throughout its whole volume by a gas, and is formed by the removal of all swelling agents from a gel without substantial volume reduction or network compaction” (Leventis, 2010).
- “Aerogels are cellular solids that feature very low density, high specific surface area and consist of a coherent open porous network of loosely packed, bonded particles or fibres whose voids are filled with ...” (Liebner et al., 2012).

Commercially available products fall into the following categories:

- granular silica aerogels such as Lumira® Cabot, former Nanogel, KWARX® from Enersens, AeroVa® from JIOS, and others;
- silica aerogel composites such as Spaceloft® from Aspen Aerogels Inc., Skogar® from Enersens, Alison, Nanuo and Airloy®, Sto-Aevero from Sto GmbH, Heck Aero from Heck Wall Systems, and Aerowolle and Aerowool from Rockwool International A/S, and others;
- organic aerogels such as polyimide (Blueshift®) or polyurethanes (Slentite® from BASF SE);
- synthetic amorphous silica boards such as CALOSTAT® from EVONIK Resource Efficiency GmbH.

There is a variety of system providers on the market combining APMs with other construction-based materials such as composites based on fibre or binder reinforcement, render or concrete, boards and daylighting.

Typical properties of APM are:

- Thermal conductivity at (20°C):
 

- granular silica aerogels	0.014 to 0.020 W/(m K);
- silica aerogel composites	0.015 to 0.020 W/(m K);
- organic aerogels	0.009 to 0.040 W/(m K);
- synthetic amorphous silica boards	0.016 to 0.020 W/(m K).

- Water vapour permeability:
  - granular silica aerogels  $\mu = 5-10$ ;
  - silica aerogel composites  $\mu = 5-10$ ;
  - organic aerogels  $\mu = 5-10$ ;
  - synthetic amorphous silica boards  $\mu = 5-10$ .
- Hydrophobicity (expressed by contact angle):
  - silica aerogels with hydrophobisation  $140^\circ$  to  $160^\circ$ ;
  - synthetic amorphous silica boards up to  $160^\circ$ .
- Fire classification:
  - granular silica aerogels B to C;
  - silica aerogel composites A to F;
  - organic aerogels: C to F;
  - synthetic amorphous silica boards A to B.
- The density of APMs ranges from  $80$  to  $200 \text{ kg/m}^3$ .

An overview of silica aerogels, especially on synthesis, properties and characterisation is given by Dorcheh and Abbasi (2008); a study on thermal conductivities on silica aerogel and its composite insulation materials by Wei et al. (2011).

An additional extraordinary feature of APM, which is related to the small size of the pores, is the weak dependence of thermal conductivity with temperature (see section 2.2). Depending on the characteristic pore size of the material the contribution of the gas to the total conductivity even might decrease with temperature. Provided an Infrared opacifier is used to diminish IR radiative heat transfer, APM may yield excellent insulation properties for high temperatures.

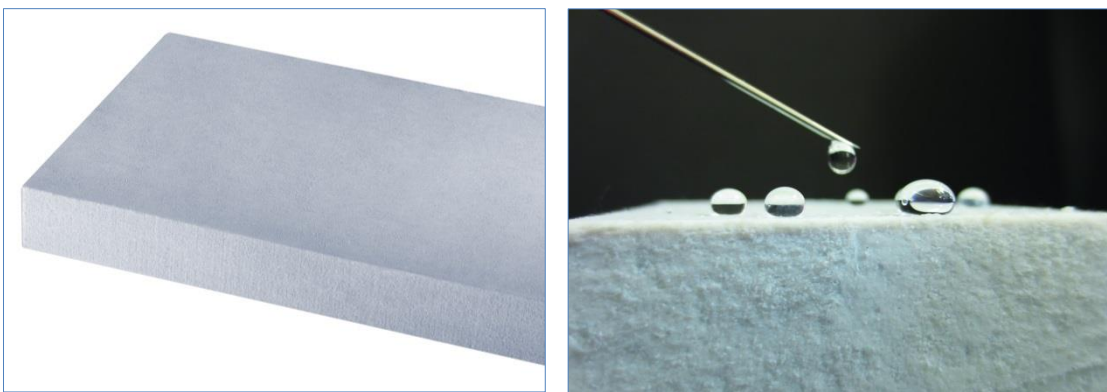


Figure 12: Amorphous silica boards. The effect of hydrophobisation is obvious by large contact angles (© Evonik).





Figure 13: Boards of organic aerogels (polyurethanes) (© BASF).

## 3.2 Characterisation methods for APM

The state-of-the art characterisation methods are:

### 3.2.1 Thermal Conductivity

The thermal performance of building materials and products is typically determined using guarded hot plate (GHP) or heat flow meter (HFM) method. For details see sections 4.5.1.1 and 4.5.1.2. The test specifications e.g. are described in EN 12667. The results are used to determine U-values.

Beside these steady-state methods, transient methods may be used. The transient methods typically are much faster than the steady-state methods. However, in order to gain reliable results, special requirements have to be fulfilled, such especially the isotropy of the specimen. If these requirements are not fulfilled these methods might be used as fast indicator for materials development in the lab or for quality control on factory site. In the appendix, three transient methods are described: the hot disk method (0), the hot wire method (0) and the hot stripe method (0).

### 3.2.2 Water vapour permeability

The water vapour permeability ( $\mu$ -value) is typically determined using the cup method with specific humidity at different level over the sample. Test specification e.g. is described in EN 12086. Results are used in hygrothermal design tools, such as WUFI, mainly to determine condensation limits.

### 3.2.3 Hydrophobicity

ASTM D570 typically determines the water vapour up-take. The results are used in hygrothermal design tools.

### **3.2.4 Fire Classification**

The fire classification might be determined according to e.g. EN ISO 13501.1.

### **3.2.5 Freeze and thaw**

A procedure to describe freeze and thaw performance of products and materials for external insulation applications that are subject to weathering is described in the European Technical Approval Guideline ETAG 004, Chapters 5.1.3.1 and 5.1.3.2.2 (ETAG 004, 2011). ETAG 004 is the guideline for European Technical Approval of External Thermal Insulation Composite Systems (ETICS) with rendering.

### **3.2.6 Health and safety**

#### **3.2.6.1 Susceptibility to mould growth**

For characterisation of susceptibility to mould growth EN ISO 846 typically is used.

#### **3.2.6.2 Health Toxicological testing**

In Europe health toxicological testing has to comply with Directive 67/548/EEC (EU Directive 67/548/EEC, 1967), Regulation (EC) No. 1272/2008 (EU Regulation (EC) No 1272/2008, 2008) and the CP-DS database on “Legislation on substances in construction products” (CP-DS database).

### **3.2.7 Wettability**

For testing wettability typically EN ISO 4618, which determines the contact angle, is used.

### **3.2.8 Mechanical properties**

Taking into account, the raw material scale, compressive strength and others, the mechanical properties are described in detail by Lu, Luo and Leventis in the Aerogels Handbook p. 500 ff (Lu et al., 2011).

Dealing with the formulated composite (including fibre/opacifier and so on) flexural strength, creep, shear should be characterised (Baetens et al., 2011). This especially holds for ceramic or plasterboards.

### **3.2.9 Density**

With respect to the “density” ( $\rho$ ), which is given by the ratio of the materials weight ( $m$ ) to volume ( $V$ ) at a given temperature and pressure, different properties have to be distinguished:

- The skeletal density, also known as true density is defined by the mass per volume of the solid itself (excluding pore spaces. Volumetric gas displacement methods such as He-pycnometer are used to measure the skeletal density.

- The bulk density, also known as apparent density or tap density, is defined by the mass per volume of the total material (including pore spaces and spaces between the particles), and can easily be measured in terms of weight to volume ratio, but depends on the degree of compaction. For APM e.g. the Standard Test Method for Apparent Density of Activated Carbon (D2854 – 09 (2014)) might be followed.
- The particle density, also known as envelope density is defined by the mass of a particle or granule per its volume (including pore spaces). Archimedes principal is used to measure particle densities. It depends on a unique displacement measurement technique. For advanced porous materials instead of liquids, quasi fluids are in use.

The porosity  $\Pi$ , which is defined by  $\Pi = 1 - \rho/\rho_s$ , with  $\rho$  the overall density of the porous material and  $\rho_s$  the density of the skeleton, can be calculated via density measurement results or if the APMs are mechanically strong enough by Mercury Porosimetry.

### **3.2.10 Structural characterisation**

Some superinsulation materials are oriented others are isotropic. Therefore, global or 2D measurement techniques are associated with 3D characterisation methods:

- 3D tomography (XR, electrons), non-destructive technique, may be coupled with properties measurements;
- microscopy techniques like SEM, TEM and FIB;
- porosity, specific surface, pore size distribution (nitrogen-, Argon- or Krypton-adsorption, Hg-porosimetry, BET, BJH, thermoporometry and other methods);
- SAXS/SANS.

An overview on structural properties and characterisation methods is given in the Aerogels Handbook by Reichenauer (2011). In addition characterisation is done by Pollanen et al. (2008), Gonçalves et al. (2016), Phalippou et al. (2004) or Roiban et al. (2016).

### **3.2.11 Thermal chemical properties**

The following methods are used for characterisation of the thermal chemical properties:

- thermogravimetric behaviour measured via TGA-FTIR;
- infrared spectrometry to assess the state of potential hydrophobisation as a global measurement technique or 2D mapping and
- the hygric behaviour via water vapour isotherms.

### **3.2.12 Long-term performance**

For testing long-term performance, typically products are stored at different conditions with respect to temperature, humidity and UV-radiation, accelerated or non-accelerated, under steady-state conditions or with cycling.

Thermal performance with time is then determined according to standard methods (see 3.2.1).

Further indicative methods investigate variation of inner surface, network deformation, mechanical strength, hydrophobicity and others. Methods are described e.g. in the Aerogels Handbook (Aegerter et al., 2011).

### 3.3 Long-term performance of APM

Within the scope of this report mainly the thermal performance, i.e. the extraordinary low thermal conductivity compared to standard insulation materials, is considered. One has to distinguish between the initial properties and the long-term performance. Main reviews on the properties of APM are available from literature, e.g. (Baetens et al., 2010; Aegerter et al., 2011; Koebel et al., 2012).

#### 3.3.1 Initial thermal performance

The initial thermal conductivity, typically determined for a mean temperature of 20°C, may be summarised for the different categories of products to:

- granular silica aerogels                      0.014 to 0.020 W/(m K);
- silica aerogel composites                    0.015 to 0.020 W/(m K);
- organic aerogels                              0.009 to 0.04 W/(m K);
- synthetic amorphous silica boards        0.016 to 0.020 W/(m K).

#### 3.3.2 Failure mode and ageing, long-term performance

In line with traditional insulation products for buildings, the anticipated lifetime is expected to be at least 50 years. Durability requirements vary in different countries and regions.

Up to now, only limited research on the long-term performance is available. Thus, part of the ANNEX 65 is to promote the understanding of the ageing mechanisms and the development of future testing methods.

Up to now, first findings are:

- Accelerated weathering, which includes UV radiation, the moisture and cyclic temperature treatment between 65°C and 35°C simulates a 20 years life time with a 10% higher thermal conductivity (Ihara et al., 2015).
- Statement of Aspen Aerogels:  
In Accordance with ETA 11\_0471, when installed in line with the best practice recommendations Spaceloft® is expected to perform for the life of the building or, at minimum of 50 years.” (ASPEN, 2014).
- In chapter 4 “Advanced Insulation Materials” of the book from Marco Casini “Smart Buildings, Advanced Materials and Nanotechnology to improve Energy Efficiency and Environmental Performance” (Casini, 2016) is in the context of

Fibre Reinforced Aerogel Blankets (FRABs) stated, "...FRABs ..., ... show no degradation of performance over time, with accelerated ageing test reaching 90 years." ASPEN Aerogels confirmed this result of 90 years operation for a service temperatures below 5°C, (Private communication Marco Cassini with ASPEN (2016/08)).

Ongoing research is dealing with the following aspects:

- durability of hydrophobic surface => influence of moisture up-take;
- densification due to physical & chemical process;
- cracking due to wetting/drying, capillary forces, freeze/thaw.
- Effects of moisture and gas (e.g. VOC, CO<sub>2</sub> or ...) adsorption on the large specific surface area can be neglected unless chemical or physical affinity is reasonable.
- Mechanical behaviour under service load (shear or compression creep for floor application);
- ... .

Results are expected to be published in 2017.

## 4 Vacuum Insulation Panels

Vacuum insulation panels (VIP) represent a state-of-the-art high performance thermal insulation solution. The pristine non-aged centre-of-panel thermal conductivity value for a VIP can be as low as 0.002 to 0.004 W/(m K) depending on the core material. Declared values for the thermal conductivity, which also account for thermal bridge effects and ageing e.g. within 25 years, typically are between 0.007 and 0.008 W/(m K) for VIPs with fumed silica cores. VIPs enable highly insulated solutions for building applications, both for construction of new buildings and for renovation of existing buildings, and hence may be a measure to reduce the energy usage in buildings without having to employ thick building envelopes.

Some kind of a historical overview on VIP was given by Fricke et al. (2008). A more recent review on vacuum insulation products was performed by Kalnaes and Jelle (2014). Even though the text comprises some deficiencies and mistakes it is a comprehensive work on the state-of-the-art literature and products. In a newer article most of the bugs have been worked out (Jelle & Kalnæs, 2016). Other review articles were performed by Wang et al. (2007), Tenpierik (2010), Baetens et al. (2010), Alam et al. (2011) and Johansson (2012).

In 1998 the first of a series of special conferences on vacuum insulation panel technology was organised by Paolo Manini from the company SAES GETTERS SPA, Milano, Italy: “European Workshop on Vacuum Panel Technology for Superinsulation in Domestic and Industrial Applications” in Milano, Italy (Manini, 1999a). This workshop was the beginning of a series of the now called “International Vacuum Insulation Symposia, IVIS”. The 13<sup>th</sup> edition IVIS 2017, will be held in Paris, France from September 20 to 21st, 2017.

### 4.1 Description of Products

A vacuum insulation panel (VIP) in general consists of a porous core (filler material) enveloped by a considerably air and vapour tight barrier (high barrier laminate). A schematic of a VIP is given in Figure 14. The core has an open pore structure to allow all the air to be evacuated, and to create a vacuum. The envelope needs to be air and vapour “tight” for the panel to uphold its thermally insulating properties over time. As no matter is perfectly tight, thus the question arises: Is the permeation rate of the entire envelope small enough to maintain the gas pressure inside the VIP on a sufficiently low level over the intended operational life span? Alternatively: What is the expected rate of degradation of the thermal performance especially that related to gas permeation?

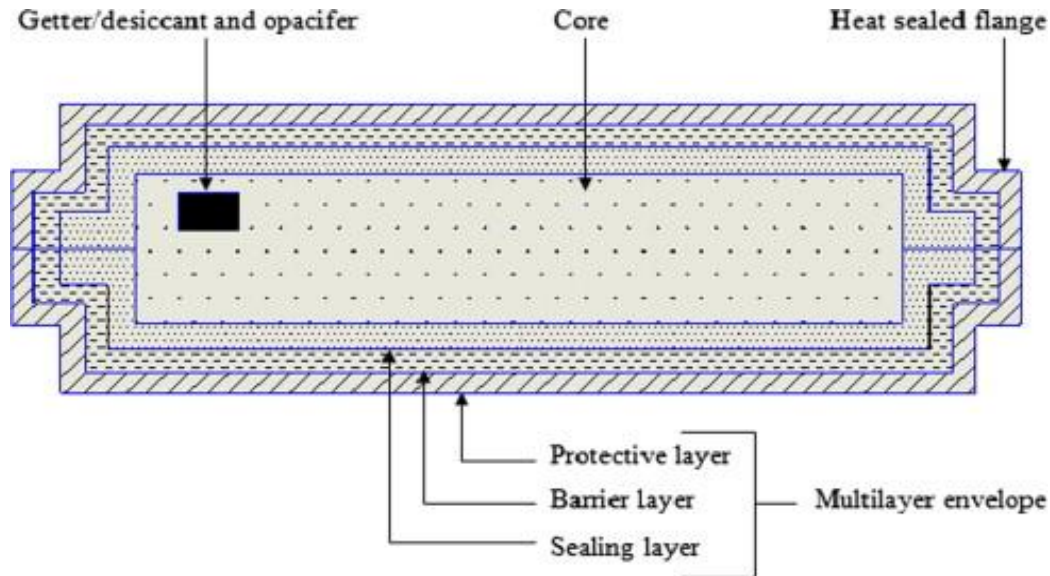


Figure 14: Schematic of a VIP (not drawn to scale) (Alam et al., 2011).

Different materials have been tested, optimised and used as cores for VIPs. With respect to the long-term performance one of the most important properties is the characteristic size of the pores. The smaller the pores the less are the requirements on the pressure level which has to be achieved and to be kept suppressing significant contribution of the gas to the total conductivity (see also section 2.2). For a broader pore size distribution most important for the characteristic pore size are the largest pores (Reichenauer et al., 2007).

The development of VIPs focuses on two main aspects of the panel, i.e. the core and the envelope. Before going into the details of the core and the envelope, different materials and films, and specifically related characterisation methods in chapters 4.2 and 4.3, in the following some groups of VIP products briefly are outlined.

With respect to the characteristic pore size, one might distinguish between:

- core materials with pores in the sub-micrometre range (up to 0.5  $\mu\text{m}$ ):  
different silica powders:
  - fumed (pyrogenic) silica,
  - some precipitated silica,
  - silica aerogel (monolithic materials, blankets or powders),
  - mixtures of fine powders,
  - ..., and
- core materials with more coarse pores (up to 100  $\mu\text{m}$ ):
  - organic open-celled foams: e.g. from polyurethane, polystyrene, polyimide, ...,
  - glass or mineral fibres,
  - inorganic granular material: e.g. perlite, granular silica aerogel,
  - ... .

The materials of the first group - non-evacuated – also might be used for advanced porous materials APM, the second group is materials, which in principle are known from standard insulation materials.

While for the fine materials a coarse vacuum of e.g. 10 mbar might be sufficient to suppress the contribution of the gas to the total heat transfer to a non-relevant fraction, for the coarse material a gas pressure of 0.1 mbar or even less might be required.

Compared to lightweight standard insulation materials the density of the filler material is much higher, typically between 150 and 300 kg/m<sup>3</sup>. It is a result of the required compression strength. The core material in a VIP has to withstand the external pressure load of the atmosphere of 1 bar, corresponding to a load by mass of 10 tons per square metre.

Two typical types of VIP mainly are used or tested for the application in buildings: VIPs with a core of compressed fumed silica powder and VIP with a core of glass fibres:

### **1. VIP with fumed silica core:**

The VIPs with fumed silica cores have a centre-of-panel thermal conductivity which typically ranges from 0.004 to 0.0048 W/(m K) in pristine condition (see the VIP-related ETAs mentioned in Chapter 1.2: ETA-13/0493, ETA-0515, ETA-13/1026, ETA-15/0090). This is 5 to 10 times better compared to traditional insulation used in buildings today. When perforated and thus loss of vacuum, a VIP with fumed silica core typically attains a thermal conductivity value typically between 0.020 and 0.023 W/(m K) (e.g. see Figure 15). Values for the declared (effective) thermal conductivity accounting for thermal bridge (edge) effects and ageing during e.g. 25 years typically range from 0.007 to 0.008 W/(m K). In order to reduce the thermal bridge effect of the envelope to a minimum, so-called metallised-high-barrier-laminates widely are used. These metallised films MF typically consist of three layers of metallised (metal coated) polymer films (PET) and an inner sealing layer of polyethylene (LLDPE) or polypropylene (PP). The typical density of the core is about 200 kg/m<sup>3</sup>.

### **2. VIP with glass fibre core**

The initial thermal conductivity in the centre of a panel ranges down to 0.002 W/(m K) or even below. Thus, the thermal insulation potential is a factor of 2 higher (better) compared to fumed silica boards. In the case of a leaking envelope the thermal conductivity in the non-evacuated state arises up to a value between 0.035 and 0.040 W/(m K), i.e. a factor of 20 higher (worse) compared to the evacuated state. The sensitivity on increasing gas pressure is about a factor of 100 higher compared to fumed silica VIP (see Figure 15). Instead of metallised films, laminates of a metal foil and polymeric films are used. These laminates typically consist of a (6 to 12) µm aluminium foil, a protecting outer polymer film and again an inner sealing layer of polyethylene or polypropylene. Compared to the metallised barrier laminates the thickness of aluminium is about a factor of 30 larger yielding a significant, non-negligible thermal bridge effect



(see Figure 4). Additionally, getters and desiccants are necessary to keep the internal gas pressure on the required lower level.

In a recent publication M. Alam et al. analysed the energetic and economic aspects of these two types of VIPs in non-domestic buildings (Alam et al., 2017).

The following companies are producing vacuum insulation panels with different kind of core materials (in alphabetic order):

**Fumed silica:**

- Dow Corning,
- Microtherm / Promat /Siniat
- Morgan-Porextherm,
- OCI,
- Kingspan,
- Turna d.o.o. / Recticel,
- Vaku-Isotherm GmbH,
- Variotec GmbH & Co. KG,
- va-Q-tec AG,
- ... .

**Glass fibre**

- Asahi Fiber Glass,
- Changzhou Sanyou Dior Insulation Materials MFG Co., Ltd.,
- Fujian Super Tech Advanced Materials Co. Ltd.,
- LG Hausys,
- Panasonic,
- Suzhou V.I.P. New Material Co., Ltd.,
- ThermoCor / AcuTemp Thermal Systems,
- Turna d.o.o.,
- va-Q-tec AG.
- ... .

**Others (PU, EPS, other silica, unknown, ... ):**

- Qingdao Kerui new environmental materials group Co., Ltd.,
- va-Q-tec AG,
- ... .

This list does not claim to be complete or the correlation to be correct.

Up to now, only products with fumed silica core got an approval for the application in buildings: in Germany beside OCI and Turna products from all companies mentioned above got an abZ (allgemeine bauaufsichtliche Zulassung), products from Kingspan,

Microtherm, Porextherm and Variotec at least also an European Technical Approval resp. Assessment ETA ([www.eota.eu](http://www.eota.eu)).

Several of these manufacturers also provide VIPs with additional layers laminated on one or both sides:

- sandwiched between mats of rubber granulate especially for the application in floors,
- sandwiched between layers of foams of polystyrene (EPS as well as XPS), where the additional layers are used to reduce the risk of puncturing the barrier laminate,
- sandwiched between sound absorbing layers,
- or even some kind of cladding which provides the outer layer of the façade.

## 4.2 Description of Core Materials

The purpose of the core material is to provide the insulating and mechanical properties. It must fulfil following requirements:

1. The porous structure needs to be 100% open, so all the gas easily can be evacuated.
2. It must be able to withstand the external pressure load of the atmosphere of 1 bar, corresponding to a load by mass of 10 tons per square metre.
3. The total conductivity in the evacuated state, which is the sum of conductivity along the skeleton and the Infrared radiative heat transfer, should be as low as possible,
4. whereas a small effective pore size is advantageous with respect to the requirement on the vacuum level, that must be achieved and to be maintained.

A first overview on different kinds of core materials, which more or less have been optimised for the use in vacuum insulation panels, was given in “Characterization and Optimization of Filler Materials for Vacuum Super insulations” by Heinemann, Caps and Fricke on the first “European Workshop on Vacuum Panel Technology for Superinsulation in Domestic and Industrial Applications” in Milano, Italy 1998 (Heinemann et al., 1999). Figure 15 is a subsequent version of the figure given on this conference. For different core materials, the thermal conductivity is depicted versus the internal gas pressure. A logarithmic scale for the pressure was chosen to illustrate the differences of the onset of significant increase, which for the different core materials varies over several orders of magnitude. A linear scale is less illustrative Figure 16.

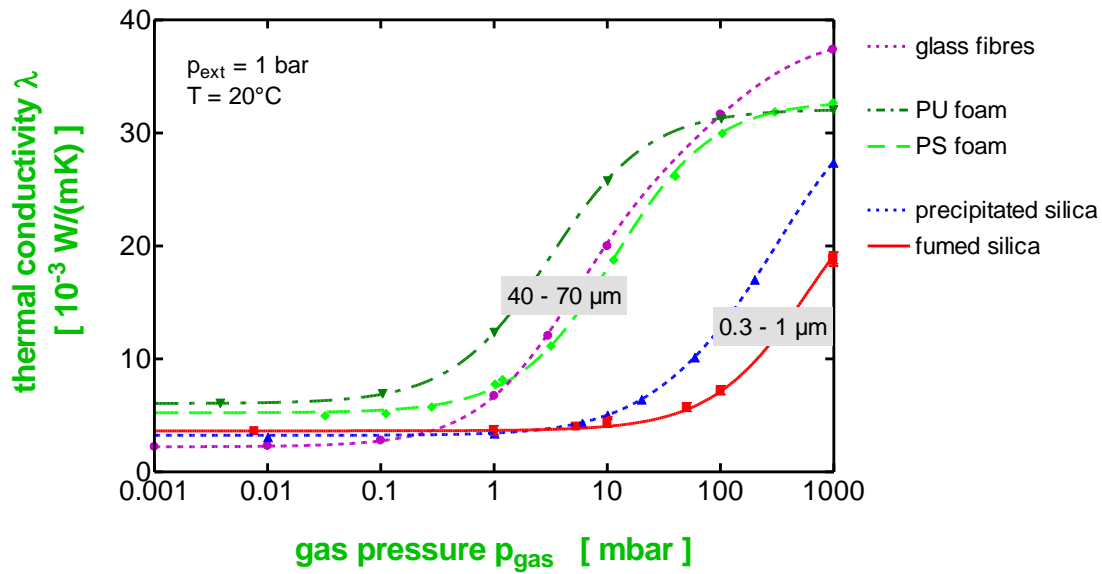


Figure 15: Thermal conductivity of different filler materials more or less optimised for the application in vacuum insulation panels. External pressure is 1 bar, the temperature 20°C (Heinemann et al., 1999; Heinemann, 2008).

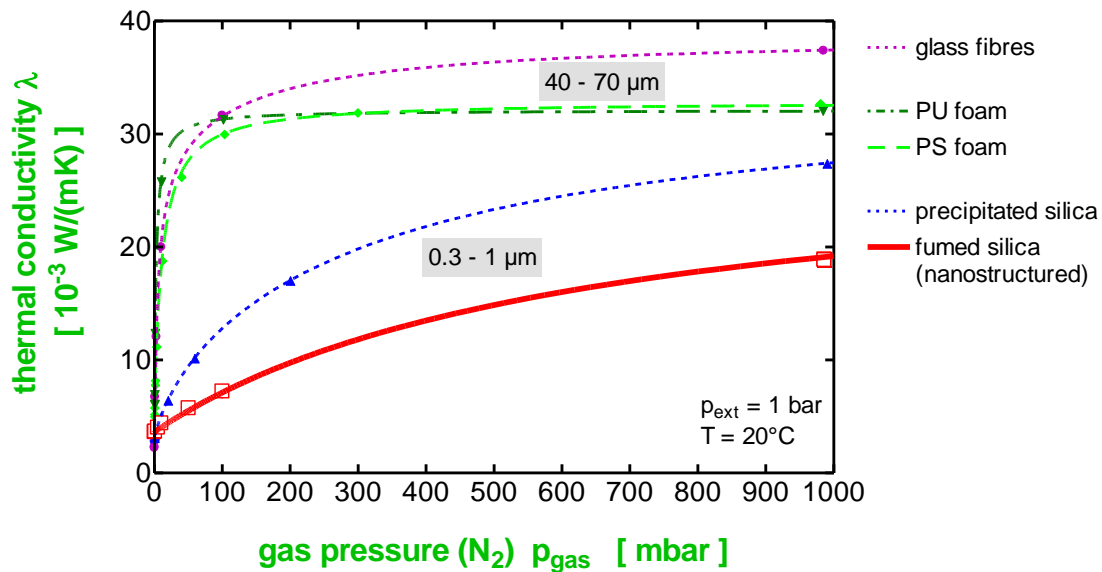


Figure 16: As Figure 15, but the gas pressure given in a linear scale.

Various types of filling materials for vacuum insulation panels have been tested, such as powders, foams, fibres or composites:

**Powders:**

- Silica aerogel powder (opacified with carbon black), precipitated silica, perlite and diatomite by T. Rettelbach (Rettelbach et al., 1996),

- Different infrared opacifiers tested in mixtures with perlite powder, precipitated silica, fumed silica and silica aerogel powder (Caps & Fricke, 2000),
- fumed silica boards, as commonly used today as core material for VIP (Caps et al., 2001),
- ,

**Foams:**

- Polyurethane foam (Biedermann et al., 2001a; Biedermann et al., 2001b),
- phenolic foam (Kim et al., 2012),

**Fibres:**

- ultrafine glass fibres (Di et al., 2013),
- borosilicate glass fibres and alumina fibres (Fricke et al., 1987)

**Composites:**

- fibre-powder composites (Mukhopadhyaya et al., 2009),

**Others:**

- polycarbonates (Kwon et al., 2009; Kwon et al., 2011),
- monolithic silica aerogels of different density (Fricke, 1994; Heinemann et al., 1996), ;

#### **4.2.1 Different Core Materials (Data)**

The various core materials have different advantages and drawbacks. In the following some more details are given.

##### **Fumed Silica**

Fumed silica is produced by pyrolysis of  $\text{SiCl}_4$ , which is then vaporised and reacts with oxygen, thus forming  $\text{SiO}_2$  which is a fine white powder. This powder is pressed into boards, normally with added fibres for structural stability and IR opacifiers to reduce infrared radiative heat transfer on (Caps & Fricke, 2000; Caps et al., 2001; Alam et al., 2014). Figure 17 shows a VIP with fumed silica as a core.

Due to its small pore size, ranging from (30 to 100) nm, and ability to withstand compression, the fumed silica core fulfils all the criteria stated earlier. The normal material properties for fumed silica are a mass density of around  $200 \text{ kg/m}^3$  and a thermal conductivity of (0.003 to 0.006)  $\text{W/(m K)}$  under an internal gas pressure of (20 to 100) mbar (Wang et al., 2007). However, pure fumed silica is not able to block thermal radiation very well. While the heat transfer through reduced gas conductivity in a vacuum panel is especially low, the contribution from radiation will give a significant relative contribution to the total thermal conductivity. Therefore, it is a common solution

to add IR-opacifiers to the fumed silica in order to reach an initial centre-of-panel thermal conductivity as low as around 0.004 W/(m K).



Figure 17: VIP with a fumed silica core (© va-Q-tec 2013).

Fumed silica is a very common core material for VIPs in the building sector today. Several advantages of fumed silica makes it a good choice for building applications. Silica is non-toxic, incombustible and recyclable, and it does not release harmful emissions to the environment. A core of fumed silica works as a desiccant, absorbing water vapour permeating through the envelope. Applying three-fold metallised laminates, yield a low thermal bridge effects. Even an internal gas pressure of about 100 mbar of dry gases might be acceptable (see Figure 15).

In the case of panel perforation, fumed silica cores will still have a rather low thermal conductivity of around 0.020 W/(m K) at atmospheric pressure. And importantly, note then that the difference between 0.004 W/(m K) (pristine condition) and 0.020 W/(m K) (punctured) of 0.016 W/(m K) is due entirely to the gas thermal conductivity.

### **Silica Aerogels**

Aerogels are produced in two steps. First, wet gel formation by acidic condensation or sol-gel process. Second, the wet gel is dried by using supercritical or ambient drying. This produces a material with pore sizes typically around 20 nm and a mass density typically between 100 and 250 kg/m<sup>3</sup>. When used as a core material for VIPs, aerogels may deliver a low thermal conductivity. At an ambient pressure of 50 mbar, and with an addition of carbon black to reduce the radiative transfer, silica aerogels may reach a low thermal conductivity of 0.004 W/(m K), whereas at ambient pressure the thermal conductivity rises to 0.0135 W/(m K) (Baetens et al., 2011; Mendenhall, 2011; Jelle et al., 2015).

Silica aerogel is non-flammable and non-reactive. However, due to its high cost, aerogel-core VIPs are not yet an economically reasonable product for building applications.

An additional approach with organic aerogels was commercialised (Mendenhall, 2011).

### **Polyurethane and polystyrene foams**

Polyurethane (PUR) and polystyrene (PS) foams are widely used thermal insulation materials by their own. PUR has the mechanical strength and can be made with an open pore structure required for a core material. However, the pore size in PUR and PS is about a factor of 100 larger than that in fumed silica and aerogel. In order to reduce the contribution of the gas to the total heat transfer to a negligible fraction, thus the internal gas pressure has to be less by the same factor (see Figure 15). A pressure below 0.1 mbar has to be achieved and maintained (Fricke et al., 2008; Yang et al., 2012). The thermal conductivity in the evacuated state ranges from about 0.005 to 0.007 W/(m K) (see e.g. (Biedermann et al., 2001a; Biedermann et al., 2001b)).

The matrix of the PU-foam releases a reasonable amount of water vapour over long time. Under practical considerations, this cannot be removed sufficiently by prior processing (Yang et al., 2012). For both types of foams, additional getters and desiccants commonly are used. PUR and PS foam core VIPs are less expensive to produce. Due to the low density of about 50 kg/m<sup>3</sup> these organic foams are used as core of VIP for applications, where weight is crucial (transport containers, boxes, ...). The expected unfavourable fire classification and the high requirements on the tightness of the envelope are strong arguments against a practical application in buildings.

### **Glass fibres**

The requirements on internal gas pressure in order to suppress significant gaseous contribution to the total thermal conductivity are quite similar for glass fibre cores and PUR foam cores, but with the advantage of lower centre-of-panel thermal conductivity values. The centre-of-panel thermal conductivity can be as low as 0.0015 W/(m K) (Fricke et al., 1987). Because of the relatively large characteristic pore size in the order of 50 µm for 10 µm fibres, the gas pressure also needs to be 0.1 mbar or less. Because of its high thermal stability, Araki et al. (2009) have investigated the use of glass fibre core VIPs for high-temperature applications. The core material itself is relatively inexpensive, but Di et al. (2013) concluded that the lifetime expectancy for a glass fibre core vacuum insulation panel is about 15 years. The typical density of glass fibre core is in the order of 250 to 350 kg/m<sup>3</sup>.

With respect to the application in buildings the high requirement on the tightness of the envelope up to now still is a challenging task. Laminates with an integrated aluminium foil yield better tightness than threefold metallised films, however they are combined with reasonable thermal bridge effects. The development of better laminates is going on. Additionally, getters and desiccants help to maintain the low internal gas pressure (see Chapter 4.4). First tests of glass fibre filled VIP applied to buildings actually are on the way (Boafo et al., 2012), which is also subject of Subtask 3 of this Annex 65.

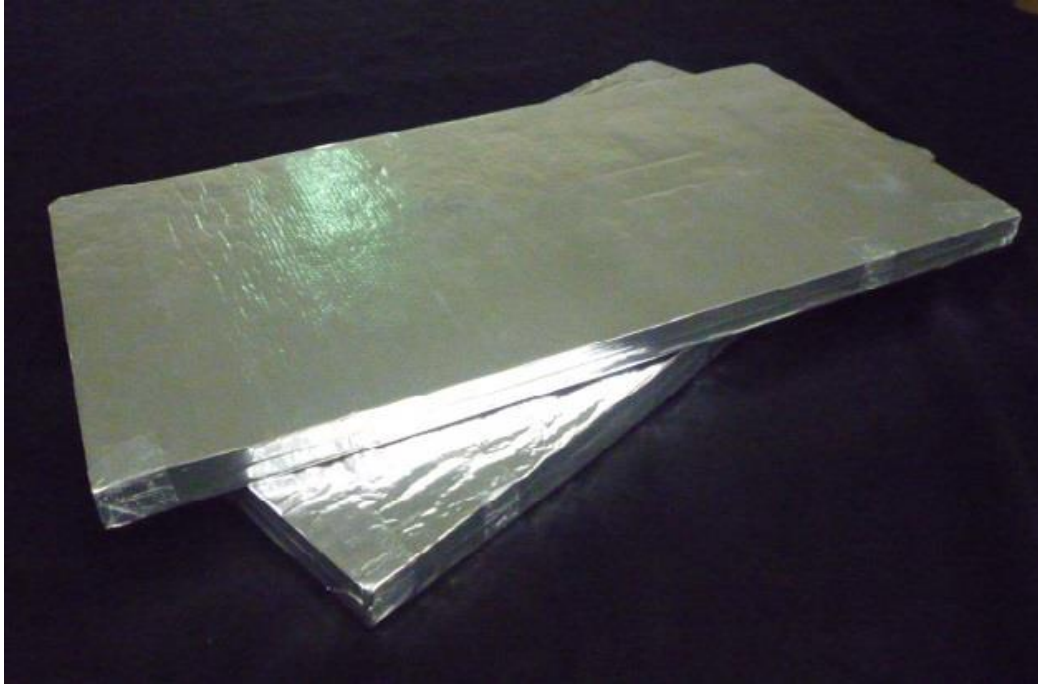


Figure 18: VIPs with glass fibre core (© Panasonic).

#### **4.2.2 Characterisation Methods Core Materials**

For a systematic characterization and optimization of the thermal properties of insulation materials and systems, especially for evacuated super insulations such as foams, glass and ceramic fibres, silica monoliths, powders and granules, mineral powders, foil systems, peg-supported systems several special guarded hot plate devices were developed and built at ZAE Bayern (Heinemann et al., 1995).

The principle of a guarded hot plate GHP is described in chapter 4.5.1.1 in the context of characterisation methods for VIP. The ZAE apparatuses are further developed GHPs. For the characterisation of materials thought as load bearing core of vacuum insulations special features are implemented:

- Instead of only one guard for the central heating unit (hot plate) as required by ISO 8302 multiple guards are implemented: two for the hot plate, one for each cold plate and an extra one in the outer region of the apparatus for one of the devices, dedicated for an extraordinary broad temperature range from  $-200^{\circ}\text{C}$  to  $800^{\circ}\text{C}$ , (see Figure 19). Thus, even for the most challenging case of extremely low thermal conductivity in the direction considered, combined with a high conductivity perpendicular, i.e. strongly anisotropic materials, as it is the case for evacuated compressed glass fibre boards, an unidirectional heat flow surely is established.
- Additionally, a special correction method compensates for residual radial heat fluxes and errors in temperature measurement (Heinemann et al., 1995).

- The stack of hot plate, samples and cold plates is integrated in a vacuum chamber; thus the gas pressure and the kind of the gas can be varied.
- In order to simulate the atmospheric pressure load, that each core material of a VIP has to bear, an external load can be applied to the GHP stack via a vacuum-tight-guided stamp. Additionally, by variation of the external load, the material may be compressed or pre-compressed. By means of thickness sensors and the prior measured masses, the density of each specimen can be determined in-situ.
- The extraordinary broad variability in the parameters gas pressure, temperature and pressure load is used to gain the necessary data basis for the analysis of heat transfer modes and coupling effects.

Examples on the analysis of heat transfer modes and on the extended range of parameter variation may be taken from several publications by ZAE Bayern (Heinemann et al., 1986; Fricke & Caps, 1988; Fricke, 1993; Heinemann et al., 1996) ... .

Typical range of parameters to be varied:

- Temperature: (-200 to 800) °C,
- Internal gas pressure: ( $10^{-5}$  to 1000) mbar,
- External load: (0 to 3) bar,
- Emissivity of the surfaces: 0.04 to 0.8.

The characterisation methods on other properties beside thermal conductivity, described in chapter 3.2 “Characterisation Methods for APM”, also can be applied to the core materials of VIP, especially those made of fine powders. This also holds for possible structural changes caused by the presence of water or water vapour, and thus a possible degradation of the thermal performance ((Collins et al., 2008; Brunner & Ghazi Wakili, 2014).



## LOLA 3

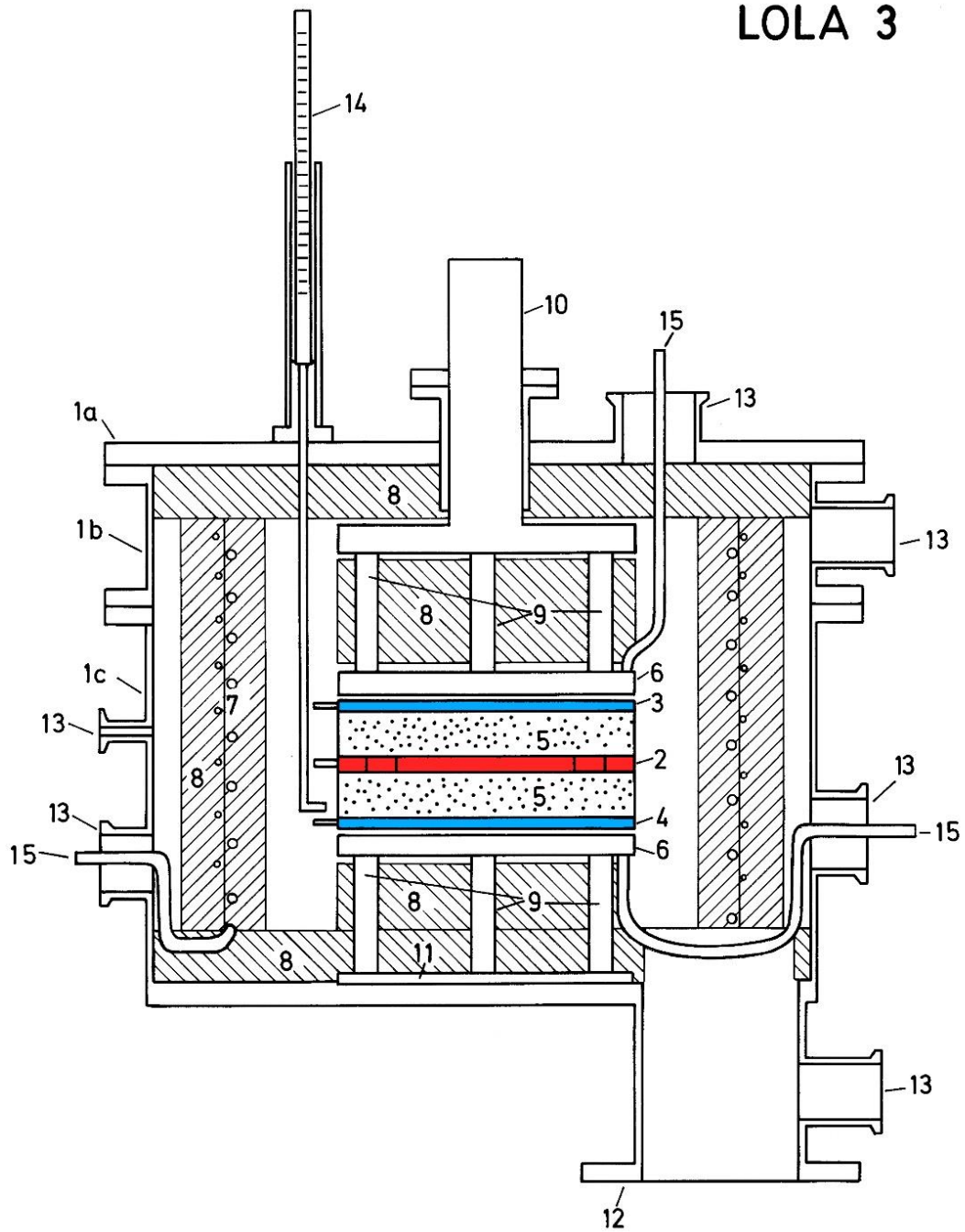
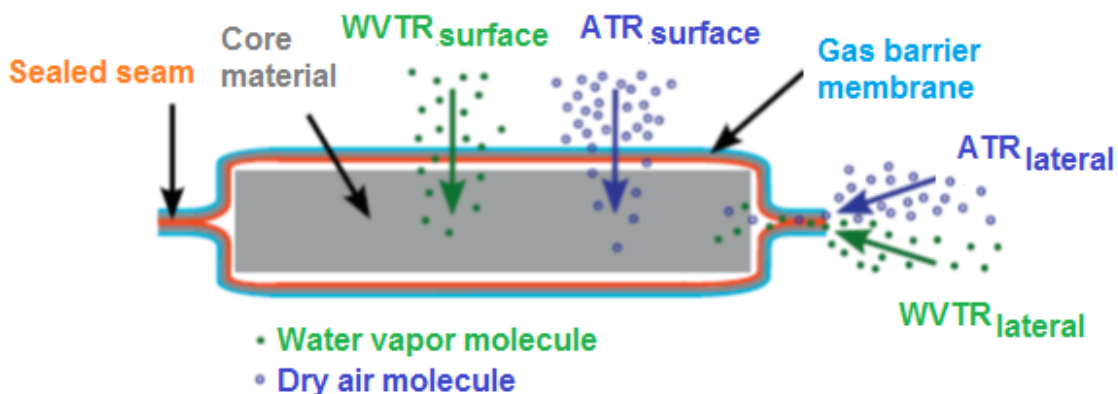


Figure 19: Diagram of the two-plate apparatus LOLA 3: 1 vacuum chamber, 2 hotplate with two guard rings, 3 and 4 cold plates, 5 samples, 6 heat sinks, 7 additional chiller or heater, 8 insulation, 9 ceramic supports, 10 vacuum-tight guided stamp, 14 three thickness sensors (Heinemann et al., 1995).

### 4.3 Description of the Envelope

In order to maintain the thermal insulation performance of VIPs during their intended lifetime, the VIP envelope has to significantly reduce the permeation of air and water vapour into the VIP core (Schwab et al., 2005b; Baetens et al., 2010; Bouquerel et al., 2012b). The required low air permeability and water vapour transmission rate of the VIP envelope depends on the targeted lifetime of the final application, the VIP core type, the VIP dimensions, and the environmental conditions such as temperature, humidity, and UV exposure that the VIP is exposed to. The atmospheric gases; nitrogen, oxygen and water vapour, permeate via two paths into the VIP, which are through (Schwab et al., 2005b; Wegger et al., 2011):

1. The surface plane of the envelope material on the top, bottom and rear sides of the VIP
2. The sealed material at the sealed seam, i.e. along the circumference of the panel and through the micro-defects possibly contained in it.



**WVTR<sub>lateral</sub>**: Water vapour transmission rate through the sealed seam

**ATR<sub>lateral</sub>**: Air transmission rate through the sealed seam

**WVTR<sub>surface</sub>**: Water vapour transmission rate through the surface plane of the envelope material

**ATR<sub>surface</sub>**: Air transmission rate through the surface plane of the envelope material

Figure 20: Gas transfer mechanisms in a VIP, picture adapted from (Bouquerel et al., 2012b).

A rough estimation on the requirements of the envelope may be performed for the core material with the least requirements on the internal gas pressure, i.e. fumed silica boards as described in (Caps et al., 2001; Simmler et al., 2005; Heinemann, 2008). Let's assume a panel size of 0.5 m × 0.5 m × 0.02 m and an acceptable increase of internal gas pressure of 100 Pa/y. Then the air permeability of the flat film has to be less than  $100 \text{ Pa} \times 5 \text{ l} / (0.25 \text{ m}^2 \times 1 \text{ a} \times 1 \text{ bar})$  corresponding to about  $0.05 \text{ cm}^3(\text{STP})/(\text{m}^2 \text{ d bar})$ . Air permeation through the seams, as well as the impact of water vapour is not taken into account here. Thus the requirements on the tightness of the envelope are even

higher. For coarse core materials as glass fibres the requirements on the tightness of the envelope in addition to it are a factor of 100 higher (see Figure 15).

A more detailed consideration on water vapour and air gas barrier requirements of a VIP envelope for building insulation applications e.g. is given in (Miesbauer et al., 2014).

In summary, a fumed silica-based VIP having dimensions of 0.5 m × 0.5 m × 0.03 m is considered. A maximum acceptable thermal transmittance of 0.2 W/(m<sup>2</sup>K) after 50 years (NanoInsulate, 2013) corresponds to an effective thermal conductivity of 0.006 W/(m K). The required barrier performance of a VIP envelope to gases is calculated for ambient conditions with a temperature of 23°C and 50% RH in the environment. For calculating the influence of water vapour on the heat transfer, a simple model by Heinemann for a specific type of fumed silica without additional desiccants for moisture absorption (Heinemann, 2008), was used. The model defines the effect of the moisture on the total thermal conductivity increase first due to an increase in the solid conduction related to adsorbed amount of water, and second to an increase of gaseous conduction proportional to the partial pressure of the water vapour. For equilibrium conditions when the internal water vapour pressure corresponds to the mean outside conditions, assumed to be 23°C and 50% RH, a maximum possible water vapour pressure of 1400 Pa within the VIP and a thermal conductivity of 0.0058 W/(m K) of the core results.

In order to fulfil the requirement not to exceed a value of 0.006 W/(m K) after 50 years the contribution of the permeating dry gases (oxygen and nitrogen) to the total thermal conductivity must not be more than 0.0002 W/(m K). For the assumed core material this corresponds to a tolerable pressure increase rate of 10 Pa/y for dry gases.

In order to estimate how the gas permeation through sealed seams contributes to this gas pressure increase, low density polyethylene (LDPE), a typical material used for seal layers, is considered. A seal layer thickness of 50 µm resulting in a seal thickness of 100 µm, and the typical seal width of 1 cm are taken for the calculations. The oxygen and nitrogen permeabilities of LDPE were used as given in (Pauly, 1999). A gas (oxygen and nitrogen) pressure increase of 7 Pa/y is found to be due to permeation through the sealed seams. Based on that, a maximum pressure increase of about 3 Pa/y should be only due to gas permeation through the VIP barrier envelope in order to fulfil the requirements. Thus the permeability for dry air of the barrier film must be lower than 0.0025 cm<sup>3</sup>(STP)/(m<sup>2</sup> d bar) at 23°C and 50% RH.

By using a VIP envelope having also good barrier properties for water vapour, e.g. a water vapour transmission rate of lower than 0.001 g/(m<sup>2</sup> d) at 23°C and 85% → 0% RH, the increase of thermal conductivity with time can be reduced.

In the example given above, the major contribution of the increase of total thermal conductivity after 50 years is due to water vapour (86%). In practice this effect can be reduced by using desiccants as additive to the core. Theoretically if the increase in thermal conductivity is only due to permeating dry gases (oxygen and nitrogen), then the increase of gaseous conduction must not be more than 0.002 W/(m K), corresponding

to a pressure increase rate of 100 Pa/y and a permeability of the barrier film of less than  $0.07 \text{ cm}^3(\text{STP})/(\text{m}^2 \text{ d bar})$  at  $23^\circ\text{C}$  and 50% RH.

In a real case scenario, for a fumed silica based core, the oxygen permeability requirement of a VIP envelope is between  $(0.05 \text{ and } 0.005) \text{ cm}^3(\text{STP})/(\text{m}^2 \text{ d bar})$ .

#### **4.3.1 VIP Envelope Structures**

There exist two types of VIP envelope structures, which can fulfil the above mentioned air and water vapour tightness needed to ensure a long-term performance:

1. VIP envelopes consisting of a laminated aluminium foil:  
They consist of an aluminium foil at a thickness of about 5 to 10  $\mu\text{m}$  combined in most of the cases with a polyolefin-based seal film (Figure 21, left picture), such as polyethylene. A cover layer is also included on the outside for the protection of the aluminium layer from mechanical damages. Aluminium foils would fulfil the required barrier performance of VIPs, but they cause a significant thermal bridge effect when they are used for encapsulation (Baetens et al., 2010; Alam et al., 2011; Bouquerel et al., 2012b; Bouquerel et al., 2012a).
2. VIP envelopes consisting of several aluminium deposited (metallised) films (VIP laminates):  
They consist of two or more layers of thin aluminium metallised polymeric films laminated to each other using an adhesive-lamination process. This multi-layered stack is then laminated to a seal film, e.g. a polyethylene-based film (Figure 21, right picture).

The metallisation is a vacuum deposition process performed by the thermal evaporation of aluminium on one or both surfaces of a polymeric substrate film. Typically used substrate films are biaxially polypropylene (BOPP), or biaxially oriented polyethylene terephthalate (PET) at a thickness from 5.7  $\mu\text{m}$  or more. In addition to these substrates, some of the VIP envelope producers use ethylene vinyl alcohol (EVOH), which is a copolymer of ethylene and vinyl alcohol, as a substrate. The thickness of the metallised aluminium can vary between 20 nm and 120 nm. Due to their much lower thickness, the thermal bridge effect for vacuum-deposited aluminium layers is significantly lower than for aluminium foils (Spregard & Holm, 2014).

Following companies (in alphabetic order) are manufacturing such polymeric films, used as component of VIP envelopes:

- Kuraray/EVAL Europe (EVOH films, not metallised and metallised),
- Toray Films Europe (BOPP & PET, not metallised and metallised),
- ... .

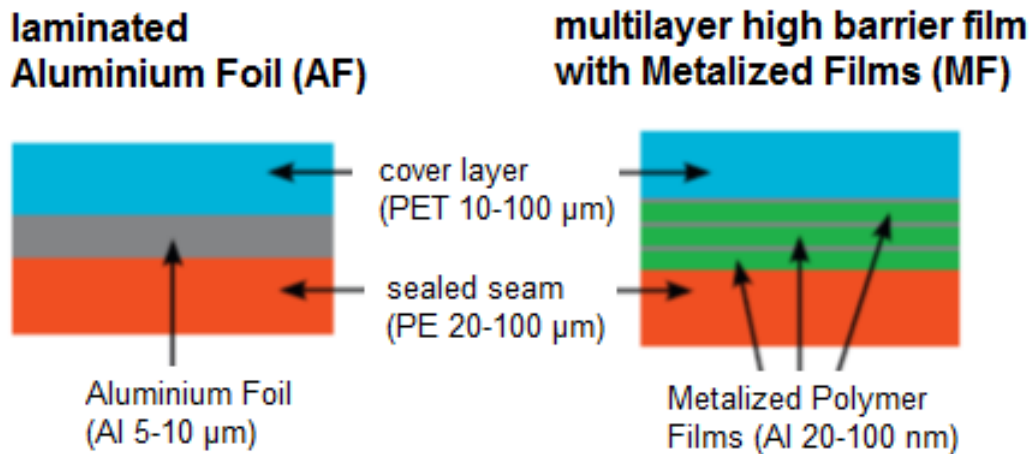


Figure 21: Typically used multi-layered VIP-laminates for the production of VIP envelopes. Picture adapted from (Bouquerel et al., 2012b).

Since the single metallised barrier film can still not fulfil the barrier requirements for the VIPs, due to the high density of defects, the metallised polymeric films are laminated two times or more to form the high barrier multi-layered barrier film structure. Solvent-based, thermally curable, two-component polyurethane (PU) based adhesive is typically used for the adhesive-lamination process. The lamination of metallised Bi-oriented polyester films (PET) with the metallised EVOH film results in a very high barrier performance both for water vapour and for air. In addition, polyethylene films such as linear low density polyethylene (LDPE), high density polyethylene (HDPE), or Bi-oriented polypropylene (BO-PP) are laminated to this ultra-high barrier (UHB) film structure to serve as seal layers (at about 50 μm of layer thickness).

Laminates containing up to three metallised films can reach gas permeabilities down to  $2$  to  $5 \times 10^{-3} \text{ cm}^3(\text{STP})/(\text{m}^2 \text{ d bar})$  at  $23^\circ\text{C}$  and  $50\% \text{ RH}$  and water vapour transmission rates of  $1$  to  $5 \times 10^{-3} \text{ g}/(\text{m}^2 \text{ d})$  at  $23^\circ\text{C}$  and  $85\% \rightarrow 0\% \text{ RH}$  and therefore can fulfil the barrier requirements for a fumed silica core based VIP for the building applications. The water intake level of such a laminate is around  $0.017 \text{ g}/(\text{m}^2 \text{ d})$  at  $40^\circ\text{C}$ ,  $95\% \text{ RH}$  and the air permeability at  $23^\circ\text{C}$ ,  $50\% \text{ RH}$  corresponds to  $\sim 6.7 \text{ cm}^3(\text{STP})/(\text{m}^2_{\text{panel}} \text{ y})$ .

The following companies (in alphabetic order) are producing VIP envelopes with the above-mentioned structures. The multi-layered VIP envelope structures are designed according to the type of the final application and the type of the VIP:

- Avery Dennison Israel LTD (before Hanita Coatings Israel),
- Rexor,
- Toppan,
- ... .

Some of the typical properties for a commercially available VIP envelope are shown in Table 5.

Table 5: Typical properties for VIP envelopes.

Property	Typical Values	Units	Test Method
Water vapour transmission rate of the flat film at 38°C, 90%RH	< 0.03*	g/(m <sup>2</sup> d)	ASTM F 1249
Sealability			T=165°C / t = 4s / P = 200N
Heat seal break HDPE / HDPE	> 45	N / 20 mm	After sealing under above conditions
Adhesive bonding strength (e.g. HDPE to UHB film)	> 3.50	N / 20 mm	ASTM D 882
Thickness (with 3 metallised substrates)	90 +/- 5%	µm	
Breaking strength - MD	> 60	N/mm <sup>2</sup>	ASTM D 882
Breaking strength - TD	> 60	N/mm <sup>2</sup>	ASTM D 882
Elongation at break - MD	> 60	%	ASTM D 882
Elongation at break - TD	> 60	%	ASTM D 882

Ongoing research is dealing with the further enhancement of gas and water vapour barrier performance of VIP envelopes. In the already finalised European funded FP7 project NanoInsulate (2013), Fraunhofer Institute for Process Engineering and Packaging (Fraunhofer IVV), Freising, Germany developed novel high barrier films for VIPs. The aim was to reduce the VIP envelope production costs by reducing the number of layers and the number of inorganic barrier layers used within the stack. With the objective to still fulfil the VIP functional requirements, the inorganic barrier layers were combined with hybrid polymeric layers. The O<sub>2</sub> permeability of these VIP envelopes was less than the Mocon<sup>®</sup> OX-TRAN<sup>®</sup> measurement limit of 5×10<sup>-3</sup> cm<sup>3</sup>(STP)/(m<sup>2</sup> d bar) at 23°C, 50% RH for the VIP barrier envelope. Similarly, the water vapour transmission rate was 5×10<sup>-3</sup> g/(m<sup>2</sup> d) at 23°C and 85% RH. Fraunhofer IVV continues the research on this topic by using various types of barrier lacquers and adhesives in the framework of the European funded Horizon 2020 project INNOVIP (2016-2019), with other industrial project partners.

#### 4.3.2 Sealed Seams

The sealed seam can have a significant contribution to the gas pressure increase due to the permeating air and water vapour through the sealed seam (Schwab et al., 2005b; Wegger et al., 2011). This contribution depends on the type of the seal material, the sealing process parameters (temperature, time and pressure), the VIP geometry (VIP effective volume, panel surface area, the length of the VIP circumference, the sealed seam width and thickness), the VIP core type, and the VIP envelope barrier performance. The sealing conditions need to be adjusted by the VIP producers according to the equipment used for VIP production in order to achieve optimal sealing.

S. Kojima et al. has calculated the dependence of the amount of gas permeation on the width of the sealed area and on thickness of the sealant layer (Kojima et al., 2011). Based on the results, a die is modelled for the reduction of gas and water vapour

permeation through the sealed seam. Figure 22 shows the geometry of this new “wave-seal” in comparison to the conventional form. According to the results shown, the gas permeation through the sealed seam made by this new heat-sealing technology “Wave Seal” becomes half compared to the gas permeation through the conventional geometry, Figure 23.

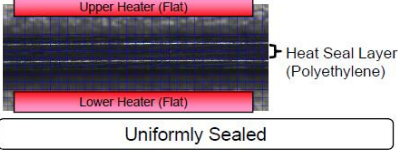
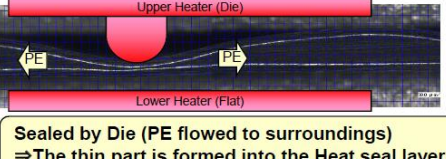
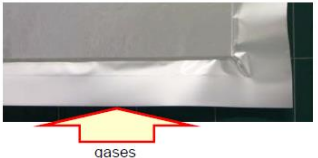
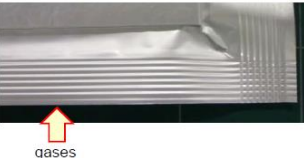
	Conventional model (Flat Seal)	New model (Wave Seal)
Heat seal technology	 <p>Upper Heater (Flat) Lower Heater (Flat) Heat Seal Layer (Polyethylene) Uniformly Sealed</p>	 <p>Upper Heater (Die) Lower Heater (Flat) PE Sealed by Die (PE flowed to surroundings) ⇒ The thin part is formed into the Heat seal layer</p>
Shape of Fin	 <p>gases</p>	 <p>gases</p>

Figure 22: New heat seal technology (Wave seal) in comparison to the conventional model (Flat seal).

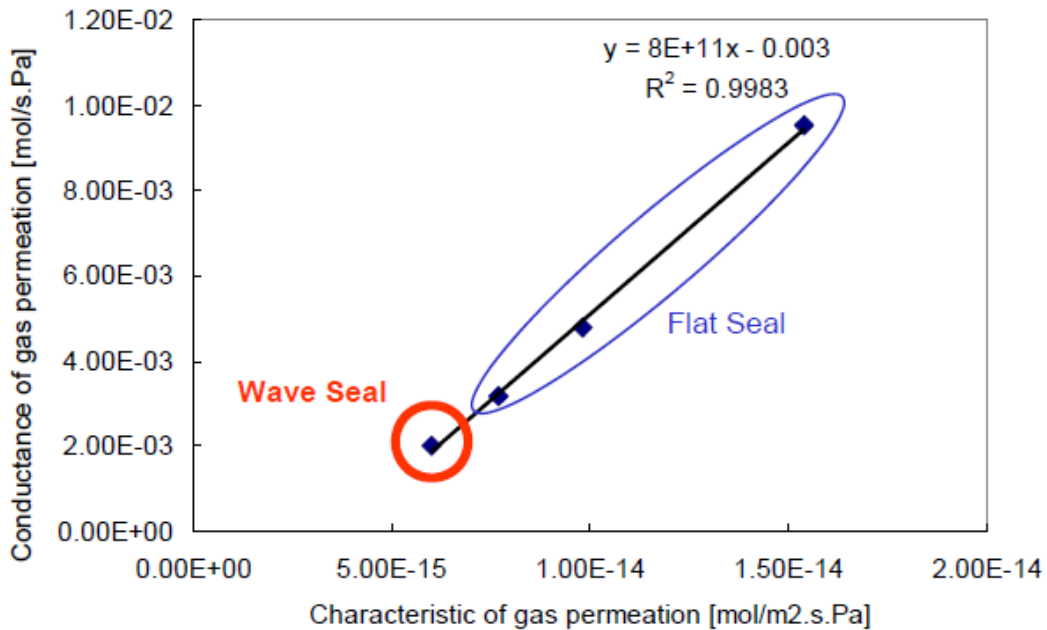


Figure 23: New heat seal technology (Wave seal): VIP size: 175 mm x 280 mm x 8 mm, Envelope: aluminium foil (6 µm) is laminated to a nylon layer (40 µm) and an inner polyethylene seal layer.

### 4.3.3 Characterisation Methods

The VIP envelopes are typically characterised in terms of their gas and water vapour barrier performance, their mechanical properties, such as heat seal performance, or adhesive bonding strength. Other related characterisation methods are the investigation of their flame retardant properties, residual gas analysis within the film, and the effect of the accelerated lifetime tests on the performance of the VIP envelope; such as degradation, delamination and thereby effect on barrier performance. The related measurement methods are described in the sections below. The samples for the evaluations described below must be carefully chosen, particularly in the case of single metallised films, to avoid the presence of macroscopic defects in the metallised layer. It can be done through an examination on a light table. Several samples of the same film or laminate have to be tested.

It is important to evaluate the gas and water vapour permeation properties of a VIP envelope both before (as a flat film) and after the VIP is produced. The latter includes the mechanical stresses that the envelope faces, when the film is converted to a panel. Therefore, the permeation measurement methods that are used for the determination of gas or water vapour permeation through the flat films and also through the envelope after the VIP production are described in the sections below. Before starting with the measurement methods for gas and water vapour permeation, below is a short section, describing the basics about permeation and relevant terms used within the community during these measurements.

#### Permeability

The permeation occurs by the solution of the gas molecules in the polymer matrix and then their transport via diffusion. According to Fick's first law, the gas flux density,  $J_{gas}$ , can be defined by:

$$J_{gas} = P_{gas} \frac{\Delta p}{\Delta x} = Q_{gas} \cdot \Delta p, \quad (27)$$

$P_{gas}$  is the permeation coefficient of a certain gas type (e.g. nitrogen, oxygen),  $\frac{\Delta p}{\Delta x}$  is the pressure difference ( $\Delta p$ ) per polymer layer thickness ( $\Delta x$ ).  $P_{gas}$  is a material property for single layered polymeric films and depends on temperature, and humidity. VIP envelopes, on the other hand, consist of more than one single polymeric film, as discussed in Section 4.3.1, therefore, the permeation coefficient,  $P_{gas}$ , cannot be used. The commonly used value term for multi-layered structures is the so-called "permeability", or "permeance", or "transmittance", which is shown as  $Q_{gas}$  in equation (27).  $Q_{gas}$  is the permeability, which is a function of the permeation coefficient,  $P_{gas}$ , and material thickness (Langowski, 2008).

The permeation mechanisms of water vapour through the polymeric films, or through VIP envelopes, on the other hand, cannot always be described using the simple Fickian behaviour as shown in equation (27) with concentration independent diffusion and solution coefficients. The most typical term used for reporting the water vapour transport



is, water vapour transmission rate (WVTR) in  $\text{g}/(\text{m}^2\cdot\text{d})$ , which during the reporting always needs to include the measurement conditions used for humidity and temperature. Table 6 shows the typical definitions with their units used for the characterization of VIP envelopes in terms of their gas and water vapour transport performance.

Table 6: List of definitions with units used for gas/water vapour transport performance characterisation of VIP envelopes.

Gas permeation coefficient, $P_{gas}$	$\text{cm}^3(\text{STP}) \text{ cm}/(\text{m}^2 \text{ d bar})$ $\text{mol}/(\text{m Pa s})$ $\text{mol m}/(\text{m}^2 \text{ Pa s})$
Gas permeance (permeability), or (transmittance), $Q_{gas}$	$\text{cm}^3(\text{STP})/(\text{m}^2 \text{ d bar})$
Flux density ( $J_{gas}$ ) or gas transmission rate (GTR)	$\text{cm}^3(\text{STP})/(\text{m}^2 \text{ d})$
Water vapour permeation coefficient, $P_{wv}$	$\text{g cm}/(\text{m}^2 \text{ d bar})$ $\text{mol}/(\text{m Pa s})$
Water vapour permeance (permeability), or (transmittance), $Q_{wv}$	$\text{g}/(\text{m}^2 \text{ d bar})$
Flux density ( $J_{wv}$ ) or water vapour transmission rate (WVTR)	$\text{g}/(\text{m}^2 \text{ d})$
IUPAC definition of STP (standard temperature and pressure)	273.15 K and 1.013 bar. 1 $\text{cm}^3(\text{STP})$ is the amount of gas that has a volume of 1 $\text{cm}^3$ in standard conditions of temperature and pressure.

### Temperature and relative humidity dependency of permeability

The permeability of VIP envelopes,  $Q_{gas}$ , generally show an Arrhenius-type of temperature dependency as shown in equation (28).

$$Q(T) = Q(T_0) \cdot \exp\left(\frac{E_a}{R} \left(\frac{1}{T_0} - \frac{1}{T}\right)\right), \quad (28)$$

where  $R$  is the gas where constant, and  $E_a$  is the activation energy.

It has been reported in literature that for the humidity values up to a value of 75% RH, the plastics of the multi-layered stack did not show a significant dependence of air permeability on the humidity (Schwab et al., 2003). The water vapour permeability, on the other hand, depends on the relative humidity.

The manometric, coulometric, and ultra-permeation accumulation methods as described in Sections 4.3.3.1, 4.3.3.2 and 4.3.3.3 below are for the measurement of gas or water vapour permeation through a flat film.

The water intake technique and the air transmission rate (ATR) measurements as described in Sections 4.3.3.4 and 4.3.3.5 are for the measurement of permeation in to a VIP. During the gas permeation measurements over a long period, the observed differences throughout the measurement time can be due to the outgassing of some residual gasses coming from the VIP envelope. These can be identified by using a residual gas analyser (RGA) as discussed in Section 4.3.3.6. The accelerated lifetime

time tests performed with VIPs at high/low temperature cycles can indicate the delamination/degradation mechanisms of a VIP envelope. Section 4.3.3.7 presents some possible examples on this. The measurement principles and procedures for all these techniques are summarised below according to the “Hanita Methodology for Testing High Barrier Laminates” (Shufer, 2017).

#### 4.3.3.1 Manometric Permeation Measurements (Water vapour, Dry Air)

##### Description of measurement principle

According to ISO 15105-1, a flat film test specimen is mounted in a gas transmission cell to form a sealed barrier between two chambers. The chambers are evacuated. A gas is introduced into the evacuated upstream chamber and permeates into the downstream chamber. The gases that can be used are water vapour, or gases like N<sub>2</sub>, or O<sub>2</sub>. The amount of gas, which permeates through the specimen, is determined by the increase in pressure of the downstream side. The measurements can be made at different temperatures and relative humidities (typically between 25 and 70°C, and 0 to 90% RH).

Equation (29) describes the gas flux density  $J_{\infty}$  once the steady-state regime is reached:

$$J_{\infty} = \frac{M \cdot V}{R \cdot T \cdot A} \frac{dp_{down}}{dt} , \quad (29)$$

where  $M$  is the molar mass of measured gas (e.g. water, or other gas types),  $V$  is the volume of the downstream chamber,  $R$  is the universal gas constant (8.314 m<sup>3</sup> Pa/(K mol),  $T$  is the temperature,  $A$  is the area of the sample,  $p_{down}$  is the pressure measured in the downstream chamber.

The permeability (e.g.  $Q_{wv}$ ,  $\Pi_{wv}$ ,  $Q_{gas}$ ) is then expressed by:

$$Q_{gas} = \frac{J_{\infty}}{\Delta p} , \quad (30)$$

where  $\Delta p$  is the difference of pressure between the upstream and downstream chambers.

##### Illustration of the functional principle

In Figure 24 the setup of a manometric permeation measurement device, the operation modes, as well as pressure versus time and flux versus time curves are illustrated.

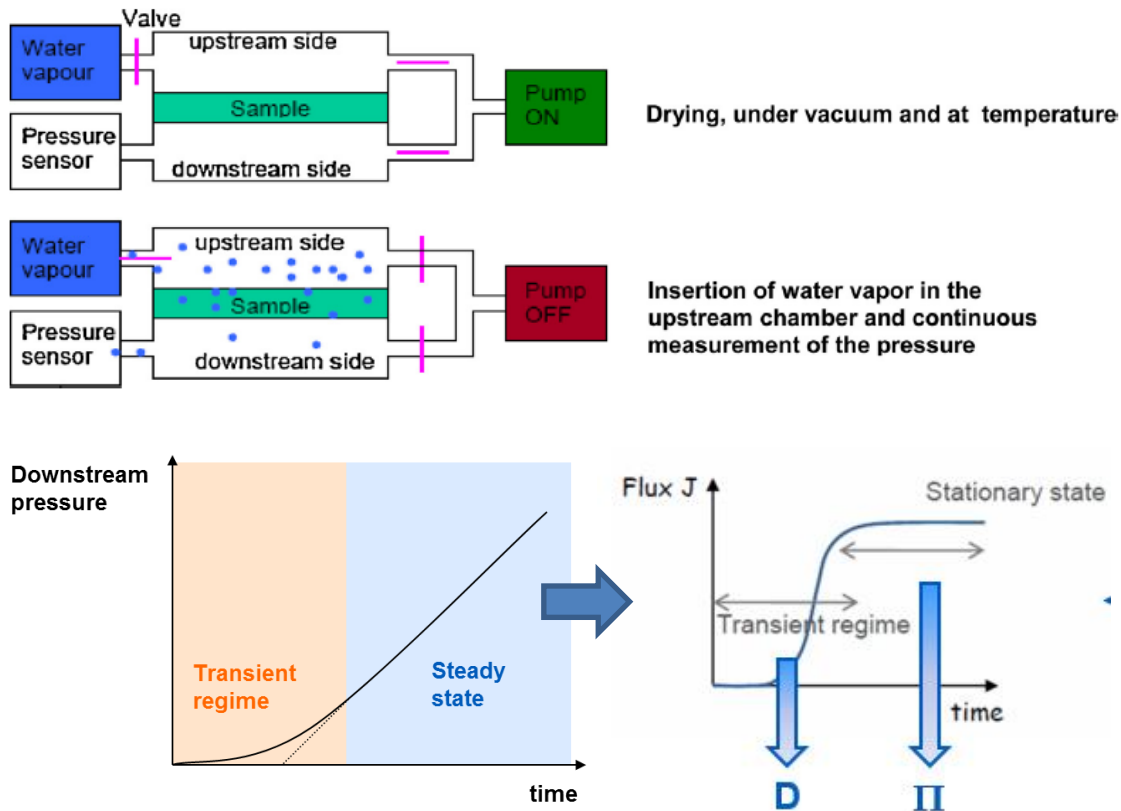


Figure 24: Top: Illustration of the manometric permeation measurement principle. Bottom: Time-dependent flux density; transient regime for calculation of diffusion coefficient,  $D$ , and stationary state for calculation of the permeability,  $Q$ .

Significant sources of uncertainty are the quality of the drying and the validity of the steady-state. It must be checked carefully that the steady stage is reached. The measurements made on multi-layer laminates take very long (typically 2 weeks for water through a 3-ply metallised laminate at temperature equal or greater than 40°C). A precaution to be taken is to use only metallic materials for the supplying gas circuits.

The related standards are ISO 15105-1 Plastics - Film and sheeting - Determination of gas-transmission rate - Part 1: Differential-pressure methods (2007) and ASTM D1434-82 - Standard Test Method for Determining Gas Permeability Characteristics of Plastic Film and Sheeting (2009). Samples must be carefully dried and degassed before testing. A vacuum drying is performed in the apparatus between 3 and 48 h according to the operating temperature and to the number of metallised layers to begin with a completely dry and degassed sample at initial state. This is of special importance, if the transient regime is used for the determination of the diffusion coefficient. For example, the typical three-metallised layers laminate must be dried under vacuum during 24 h at 60°C or 72 h at 40 °C.

#### 4.3.3.2 Coulometric Permeation Measurements (Water Vapour, Oxygen)

##### Mocon® PERMATRAN-W 3/31 (Water Vapour)

PERMATRAN-W 3/31 is a commercially available instrument for WVTR measurements from the company Mocon®. The measurements are performed according to ASTM F-1249 on flat film samples (as produced, without any mechanical stress). The sample of flat barrier film to be tested is mounted in a two-compartment permeation cell. A constant water vapour pressure is maintained on one side of the sample to keep the cell at 100% relative humidity. On the other side, extremely dry carrier gas, nitrogen (N<sub>2</sub>), picks up the water molecules permeating through the sample. The N<sub>2</sub> then exits the cell and passes through Infrared (IR) sensor (Figure 25). The sensor measures the amount of water vapour and the WVTR is calculated. The detection level of the Mocon® Permatran-W3/31 device is limited to 0.01 g/(m<sup>2</sup>·d), which is much higher than the WVTR level of high barrier films for VIPs (Figure 26).

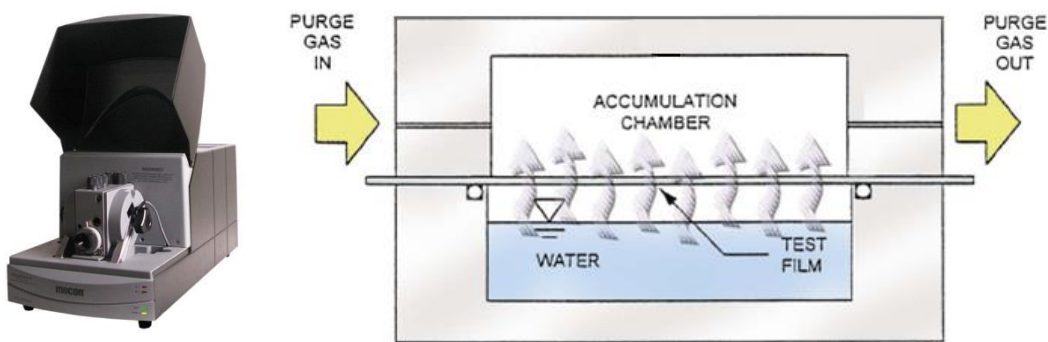


Figure 25: Mocon® PERMATRAN-W 3/31 on the left. Schematic view on the right.

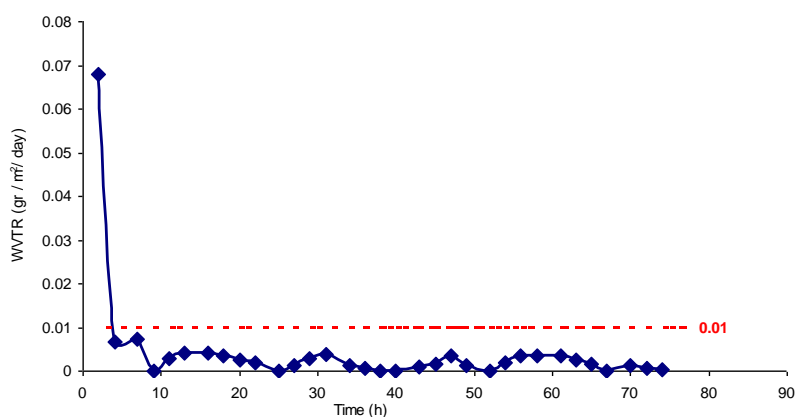


Figure 26: WVTR of Hanita 3 ply laminate (with three metallised substrates) as a function of measured time (Mocon® Permatran-W 3/31).

### Mocon® AQUATRAN™ Model 2 (Water Vapour)

The coulometric measurements are performed according to DIN EN ISO 15106-3 for water vapour on flat film (as produced, without any mechanical stress). AQUATRAN™ Model 2 is commercially available from the company Mocon®. The detection limit is  $5 \times 10^{-5} \text{ g}/(\text{m}^2 \text{ d})$ . Temperature range is up to  $40^\circ\text{C}$ , controlled relative humidity testing is up to 90%. The detection limit is sufficient for the determination of moisture permeation through the flat VIP-laminates. In the device, the measurement cell is divided by the sample into two chambers. In one chamber, constant relative humidity and temperature is maintained. The second chamber is purged using a carrier gas (dry nitrogen), which guides the permeated water molecules to a coulometric sensor (Figure 27). The sensor itself is based on phosphorous pentoxide ( $\text{P}_2\text{O}_5$ ) coated electrodes. The  $\text{P}_2\text{O}_5$  absorbs all incoming water molecules, which are then electrolyzed by a voltage across the electrodes. Therewith, an electrical current between the electrodes is induced that is measured and used to calculate the WVTR (Mocon, 2014).

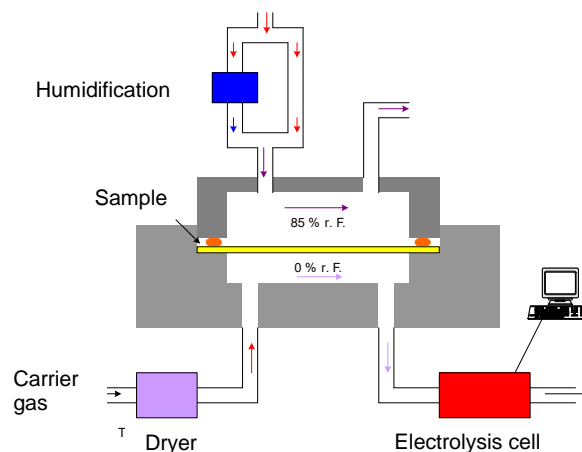


Figure 27: Mocon® AQUATRAN™ Model 2 on left. Schematic view of measurement principle on right.

### Mocon® Oxtran® Model 2/21 (Oxygen)

The measurements are performed according to DIN 53 380, T3 for oxygen permeability. It is a commercially available instrument from the company Mocon®. A photo and a schematic are depicted in Figure 28. The detection limit is  $5 \times 10^{-3} \text{ cm}^3(\text{STP})/(\text{m}^2 \text{ d bar})$ . Temperature range is up to  $40^\circ\text{C}$ , controlled relative humidity testing is up to 90%. The measurement principle is similar to the Aquatran® Model 2. The sensor consists of a graphite cathode and a porous cadmium anode. The permeated oxygen is transported by the carrier nitrogen gas to the sensor and absorbed in the cadmium anode, where it reacts with the Cadmium. The oxidation of the cadmium anode creates electrical current, which can directly be calculated into the oxygen permeability.

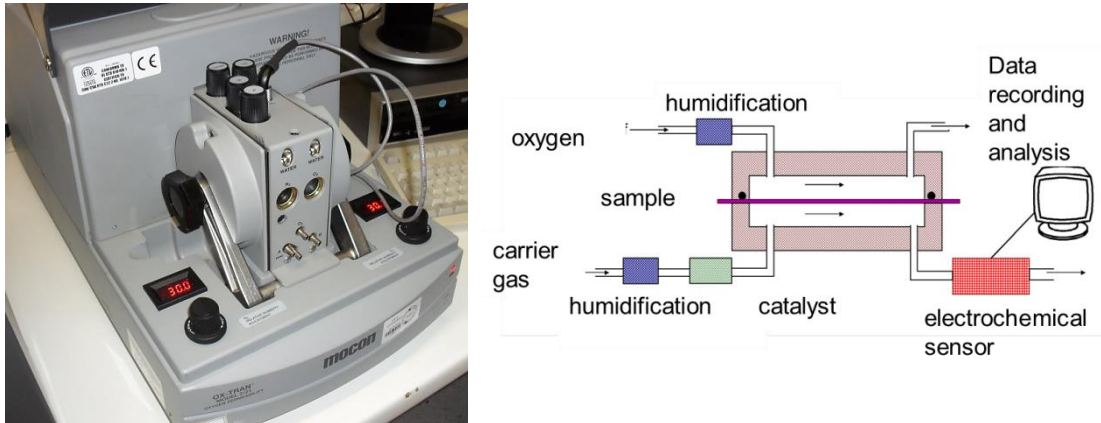


Figure 28: Oxtran® Model 2/21 (top). Schematic view of measurement principle (bottom).

#### 4.3.3.3 Ultra-Permeation Accumulation Measurement – UPA (Water Vapour)

This device used for WVTR measurements is a novel developed instrument by Fraunhofer Institute for Process Engineering and Packaging (Fraunhofer IVV), Freising, Germany (Kiese et al., 2017). It is a modified ultra-low permeation measurement device based on a constant-flow carrier-gas-system to measure both the transient and the stationary water vapour permeation through high-performance barrier films (Figure 29). It is based on the accumulation of water vapour and an appropriate evaluation method (Figure 30):

- Sample measurement area is up to  $188 \text{ cm}^2$ , precise temperature control is possible within broad ranges of temperature ( $23^\circ\text{C}$  to  $80^\circ\text{C}$ ) and RH (15% to 90% RH).
- The steady-state WVTR values can be determined more rapidly, because measurements can be taken at high temperatures, with 30 measurement cells operating at the same time dependent of the barrier performance of the samples.
- Fraunhofer IVV has combined the measurements with advanced theoretical calculations based on the finite element method (FEM) allowing the prediction of the steady-state WVTR values accurately, long before the steady-state conditions are reached. By this way, the long measurement times required for reaching the steady state WVTR for VIP envelopes are significantly reduced. Numerical solution of the diffusion equation allows us to calculate the diffusion,  $D$  and the solubility  $S$  values of each layer of the multi-layered structure.
- The detection limit of this instrument is  $2 \times 10^{-5} \text{ g}/(\text{m}^2 \text{ d})$ .

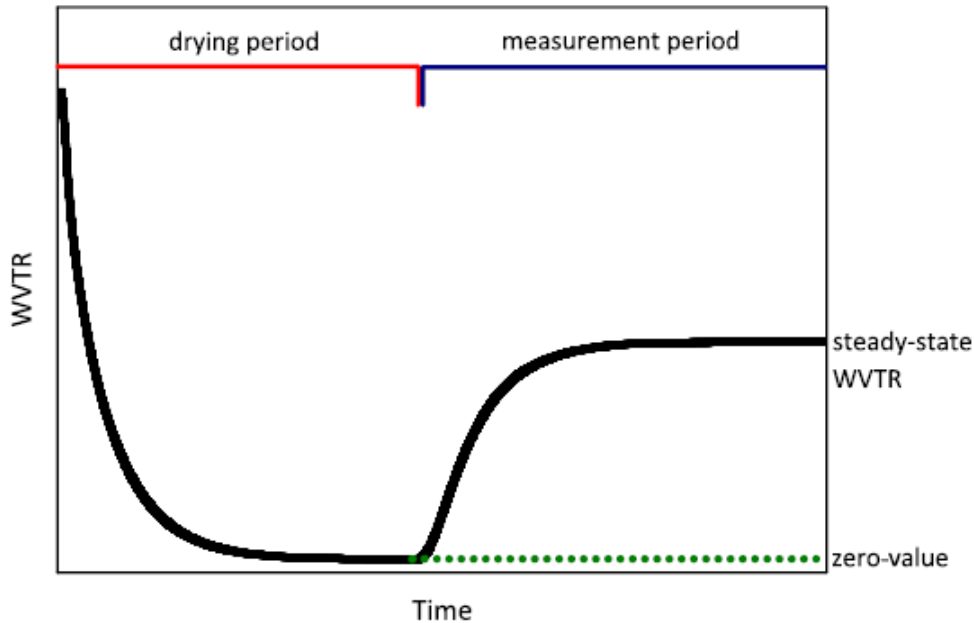


Figure 29: Schematic representation of the time-dependent WVTR showing an initial drying period and the measurement period (figure used with permission from Kiese et al. (2017)).

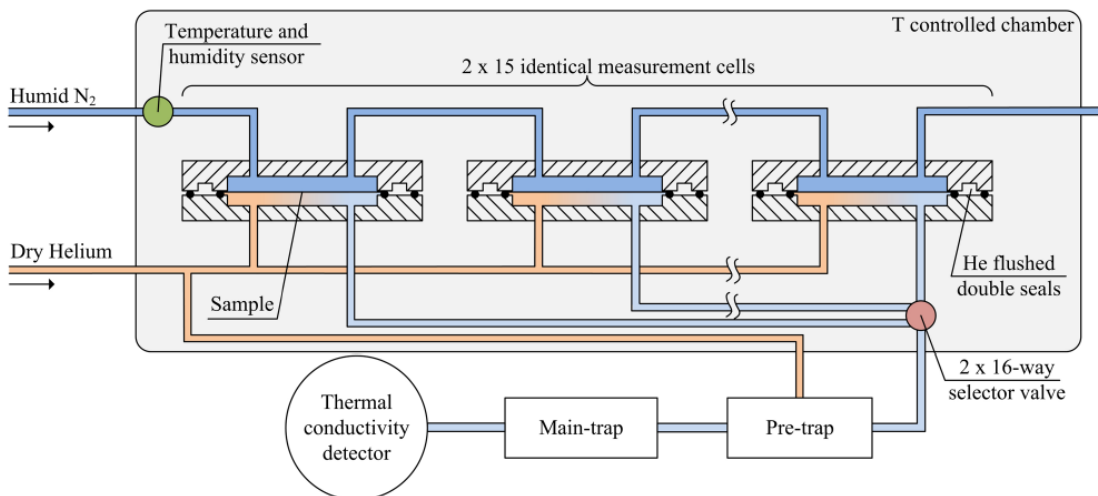


Figure 30: Cross-sectional schematic view of the UPA device based on the accumulation of water vapour on a pre- and main-trap of Chromosorb® 104 and Tenax®, respectively. (figure used with permission from Kiese et al. (2017)).

#### 4.3.3.4 Water Intake (Gravimetric) Technique for WVTR of VIP Envelopes

This technique determines the WVTR through the VIP envelope after the VIP production. The procedure starts with the preparation of small fibre glass core based panels (~15 cm x 12 cm) with desiccant inside using the inspected film (Figure 31, left). The panels are weighed using a microbalance, and then held in a humidity oven at 40°C and 90% RH (Figure 31, right).



Figure 31: (left) Small panel (~15 cm x 12 cm) with glass fibre and desiccant; (right) weighing the panel with an analytic balance (Shufer, 2017).

Over the coming months, the panels are weighed once a week. The mass gain during this period is caused by the water molecules permeating and absorbed by the desiccant. Theoretically, the water permeation rate is about 1000 faster than the permeation rate of air, therefore the contribution of the weight gain of air permeation is negligible. At the end of the test period, the WVTR of the panel (depending on the type of the envelope only) is calculated by dividing the mass gain by test duration and the area of permeation.

The main advantages of the Water Intake (WI) technique are its low detection limit (due to longer test duration) and the realistic values achieved due to testing at an application level. The results obtained include the contribution of the water vapour transmission through the film surface and the sealed seam. The detection level of the WI test is around  $0.002 \text{ g}/(\text{m}^2 \cdot \text{d})$ , which is 5 times lower than the detection level of for instance Mocon<sup>®</sup> PERMATRAN-W 3/31 instrument.

#### **4.3.3.5 Air Transmission Rate (ATR) Measurements of VIP Envelopes**

This procedure describes the measurement of air permeability through the VIP envelope after the VIP production. The air transmission rate through the VIP envelope is measured using the evacuated fibre glass (FG) core based panels according to the following procedure:

1. Produce a 30 cm x 30 cm, 3-seal bag using the sealing machine shown in Figure 32.





Figure 32: Heat-sealing machine.

2. Insert a FG core with a known dependency of thermal conductivity on gas pressure plus desiccant into the bag (after being baked at 150°C for more than 2 hours) (Figure 33).



Figure 33: VIP before evacuation.

3. Evacuate the panel to a pressure lower than 0.01 mbar, and seal the open (fourth) edge (see Figure 34).

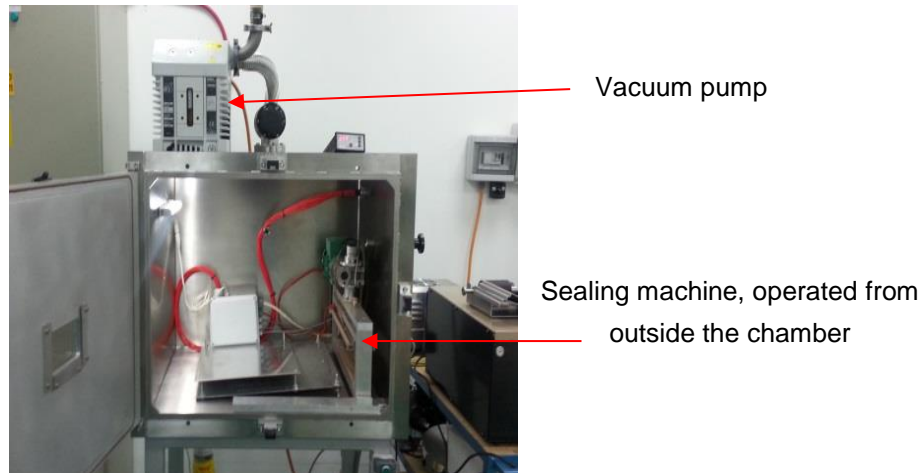


Figure 34: Vacuum chamber.

4. After preparation, store panels at different temperature and relative humidity levels, and measure their thermal conductivity frequently using a Laser Comp thermal conductivity measurement device (Laser Comp FOX314), over long period of time. In most cases, the panels are stored at a wide range of temperatures (4°C, 23°C, 40°C, 50°C/70%RH and 80°C). The thermal conductivity of each panel is measured over at least 3 months. Pressure is then calculated from the measured values of thermal conductivity using the known thermal conductivity versus pressure curve of the FG core (Reichenauer et al., 2007), enabling a very accurate assessment of internal pressure increase along the storage time (Shufer, 2017).
5. In the final stage, the air transmission rate, ( $\text{cm}^3(\text{STP})/(\text{m}^2 \text{ y})$ ), of the laminate for a given temperature is calculated using the pressure increase rate and the panel dimensions (width, length and thickness). This calculation will give the amount of air ( $\text{cm}^3(\text{STP})$ ) permeating through the envelope of a 1  $\text{m}^2$  panel in a year.

Figure 35 shows internal pressure as a function of test duration for a commercially available Hanita 3-ply laminate at 50°C/70%RH. The graph shows two different linear segments (a and b), each described by a trend line, whereby the slope represents the pressure increase rate. It is clearly shown that the pressure increase rate at the initial stage is larger by factor of about 2. This phenomenon refers to outgassing, which contributes substantially to the pressure increase rate in the first few weeks after panel production. This initial period should be excluded from the permeability calculation.

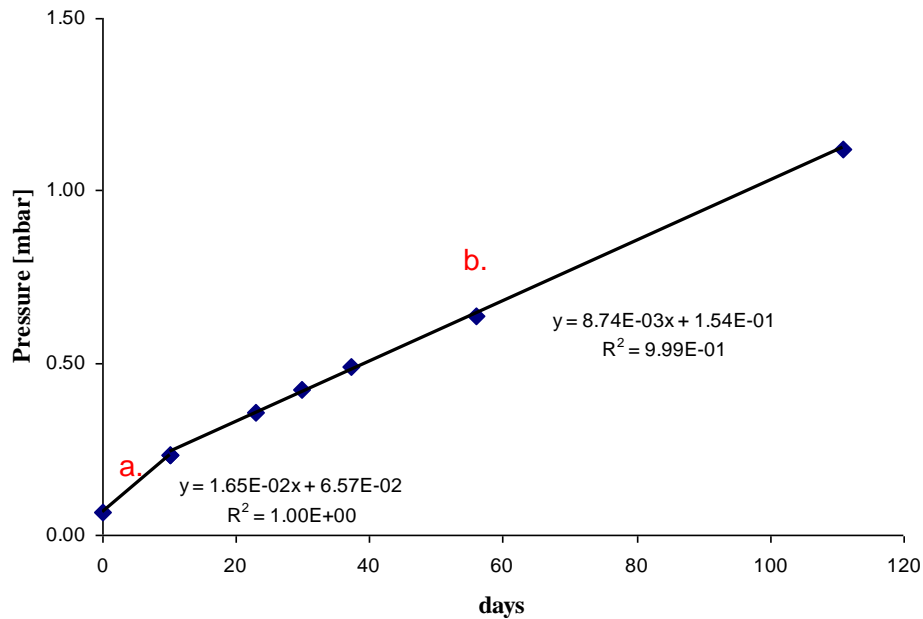


Figure 35: Internal pressure as a function of time for Hanita 3-ply laminate stored at 50°C/70RH.

Outgassing occurs at all temperatures; its duration is longer at a lower storage temperature. At ambient temperature, it may take about 2 months before the contribution of outgassing to the pressure increase rate becomes insignificant and can be ignored. The pressure increase rate should be determined solely by the steady state permeation rate of air through the envelope. In general, the permeability should be calculated using only the pressure increase after steady state has been reached, and the outgassing effect negated. The origin of outgassing can be analysed using an RGA (residual gas analyser) as explained below.

#### 4.3.3.6 Analysis of Residual Solvents in a VIP Envelope by Residual Gas Analyser

The following procedure is followed for the analysis of residual solvents in a VIP envelope by means of a residual gas analyser (RGA). Figure 36 shows the set up for analysing the residual solvents in the VIP envelope (Shufer, 2017).

1. The whole system without the inspected film (closed vacuum valve) is pumped down to a low pressure of  $10^{-4}$  mbar. The system then records the background partial pressure of all molecular weights from 1 amu to 200 amu.
2. The cavity with the film inside is stored at 80°C for 3 h to encourage outgassing from the film to the cavity.
3. The cavity is then connected to the RGA set up.
4. A small amount of gas from (a) is inserted into the RGA by opening the vacuum valve. The scan is recorded as a film test.

5. At the final stage, the difference between the two scans is calculated for each molecular weight.
6. The differences between the two scans for each molecular weight are the measured partial pressures of the molecules with the different molecular weights (the partial pressures inside the RGA SYSTEM).

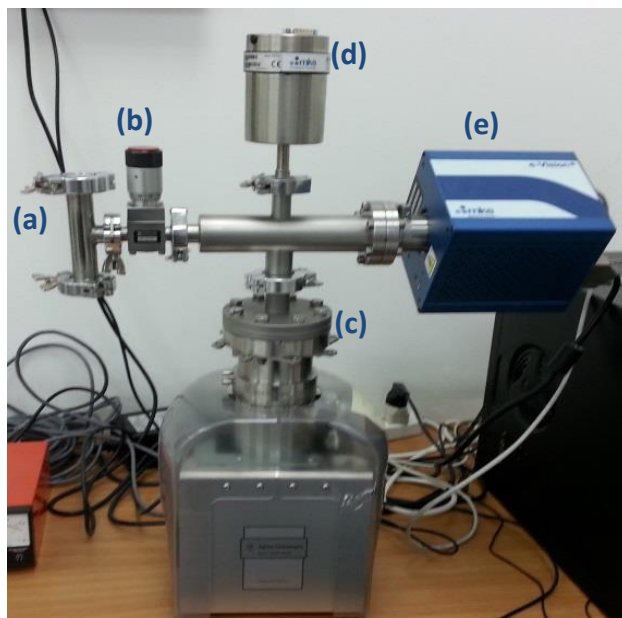


Figure 36: RGA setup. (a) Small cavity with inspected film and small bag of CaO desiccant (optional), (b) Vacuum needle valve, (c) Vacuum turbo molecular pump, (d) Vacuum gauge for monitoring the amount of gas entering the RGA unit, (e) RGA unit with connection to computer.

The spectrum in Figure 37 presents typical results for an RGA analysis, revealing that no residual solvents exist in the film, as shown by the absence of peaks at high amu. The only gas detected was air (nitrogen + oxygen); the amount of water decreases below the background level due to its absorption by desiccants.

It is important to mention that this measurement does not provide information on the absolute value of the partial pressure of the different molecules inside the tested compartment. However, it provides very accurate information about the relative concentration of the different molecules in the tested compartment.

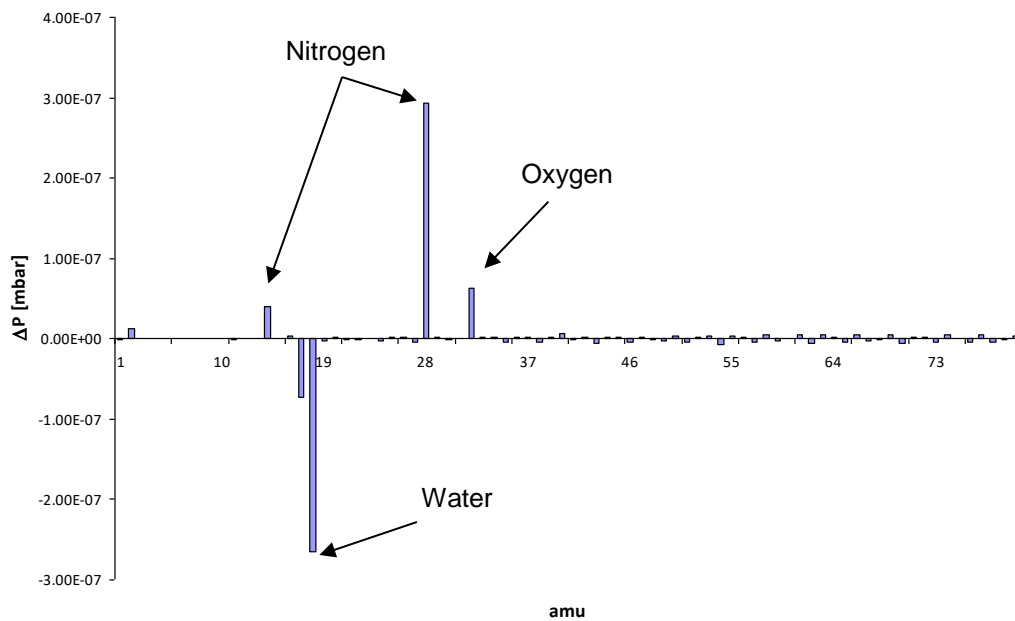


Figure 37: RGA scan. Source (Shufer, 2017).

#### 4.3.3.7 Accelerated Life Testing (ALT) of VIP Envelopes

This test enables a comparison between different ultra-high barrier film laminates and supports to understand the adhesive, substrate related degradation, delamination mechanisms during accelerated life testing ALT. During ALT, VIPs are stored in a climate oven with periodically cycling conditions. During the test, the panels are exposed to extreme conditions:

- 2.5 hour at -30°C, dry,
- 5.5 h at 80°C and 65% relative humidity,
- and back to the first condition.

Each cycle lasts 9 days, and the test consists of 4 to 5 cycles, with thermal conductivity measured after each cycle. The results of three ALT tests on several types of laminates are presented in Figure 38. This test enables a comparison between different laminates. For example, Figure 38 leads to the following conclusions:

1. Laminate 1 fails almost immediately: The failure mechanism is due to barrier degradation caused by high temperature and RH. This result correlates with high permeability at 50°C/70RH.
2. Laminate 2 fails after 2 cycles: Such a failure is typically due to degradation of the adhesive layer resulting from exposure to the combination of elevated temperature and high levels of humidity.
3. Laminate 3 stands the test quite well: Thermal conductivity increase is due to gas permeation only, and all the laminate films and the adhesive layer survived the test well.

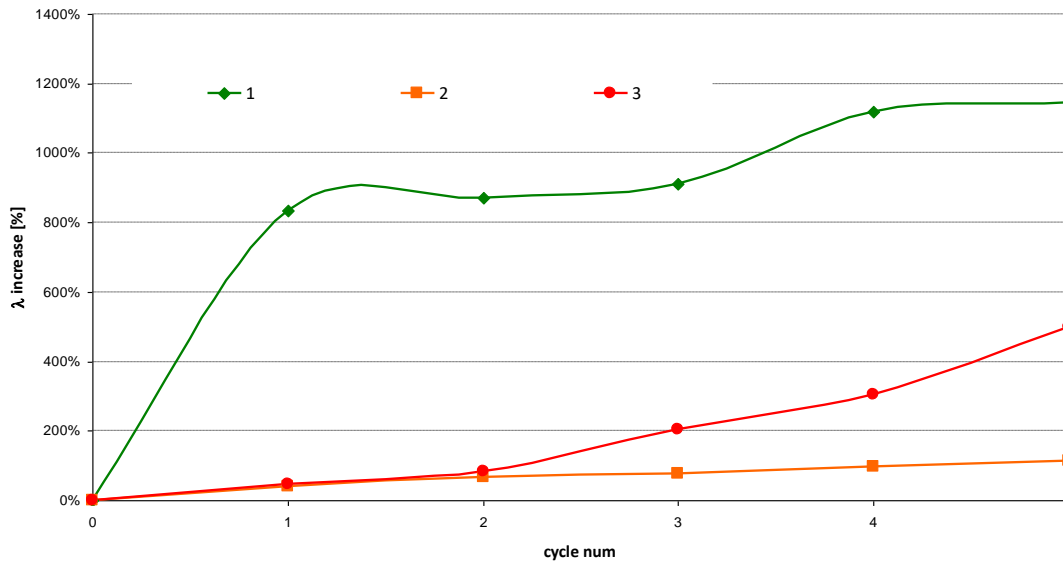


Figure 38: Thermal conductivity increase of 3 different laminates as a function of cycle number of ALT tests, source: (Shufer, 2017).

#### 4.3.3.8 Mechanical Properties of VIP Envelopes

The typical mechanical properties tested are laminate bond strength, sealing strength, puncture resistance, tensile strength and elongation at break point.

1. Lamination bond strength between the layers needs to be tested on each production roll at each lamination stage. The measured laminate bond strength values should be above  $> 3.50 \text{ N} / 20 \text{ mm}$ .
2. Tensile strength and elongation at break point: Tests on final product, similar to ASTM D882.
3. Puncture resistance. Tests on final product, similar to FTMS 101C 2065 or ASTM D4833M.
4. Sealing strength: Tests on final product, similar to ASTM F88M. The measured sealing strength should be above  $> 45 \text{ N} / 20 \text{ mm}$ .

Avery Dennison Israel LTD (previous Hanita Coatings, Israel), producer of VIP envelopes, uses Lloyd Tensiometer Unit, as shown in Figure 39 for testing the mechanical properties of the VIP laminates.



Figure 39: Lloyd Tensiometer as an example unit for testing mechanical properties of VIP envelopes (Shufer, 2017).

#### **4.3.3.9 Flame Retardant (FR) Properties - DIN4102 of VIP Envelopes**

The flame retardant properties of a laminate are determined by exposing a small VIP to fire for a period, as dictated by the standard, and measuring the height that the flame reaches. For example, in order to achieve rating B2 in DIN 4102, the flame should not pass a certain distance over a certain period (see Figure 40).



Figure 40: FR measurement setup.



## 4.4 Description of Getters und Desiccants

Getters are chemicals that absorb gases; desiccants are chemicals that absorb moisture. Getters and desiccants are used to extend the life of VIP by absorbing unwanted gases and moisture that promote heat transfer within the evacuated space. To be effective, the getters and desiccants must be carefully matched to the kind and quantity of gas/moisture they will be expected to absorb. Besides that, getters and desiccants must also be capable of effectively absorbing and holding the gases and moisture at the required low level of the pressure inside the VIP.

Two sorption mechanisms must be distinguished: chemisorption and physisorption. Chemisorption is a kind of adsorption which involves a chemical reaction between the surface and the adsorbate. New chemical bonds are generated at the adsorbent surface with a strong interaction between the adsorbate and the substrate surface. In contrast with chemisorption is physisorption, which leaves the chemical species of the adsorbate and surface intact. The fundamental interacting force is caused by van der Waals force and hydrogen bonding. The interaction energy for physisorption is very weak.

A comprehensive report on getters, the history, sources of gases, mechanisms of gettering, types of getters, fabrication, characterization, applications, and advantages and disadvantages is given by Rajeshuni Rarnesharn (2000). Furthermore work is described in (Ramesham, 2004) and (Ramesham, 2009). Reviews are given in (Ramesham & Kullberg, 2009) and (Kullberg & Bradley, 2012).

The required pressure level inside a VIP is related to the structure of the core material. The coarser a material the higher are the requirements on the quality of the vacuum (see Figure 15). For cores made of fibres or foams with a typical characteristic pore size in the range of 20 to 100  $\mu\text{m}$  a pressure level below 10 Pa is needed. For cores made of fumed silica with a characteristic pore size typically in the range of 0.3 to 1  $\mu\text{m}$ , a factor 100 smaller, correspondingly a 100 times higher pressure level of 1000 Pa might be enough.

The fumed silica material, due to a huge inner surface of several hundred square meters per gram, may bind reasonable amounts of water vapour by physisorption (several percent by weight) (see Figure 41). In some foam-based panels due to water that is solved within the matrix, which under practical considerations cannot be removed prior to evacuation (Yang et al., 2012), at least desiccants are necessary.

It is, therefore, important that the quantity and type to be selected are in accordance to the core material, membrane film and required life expectancy.

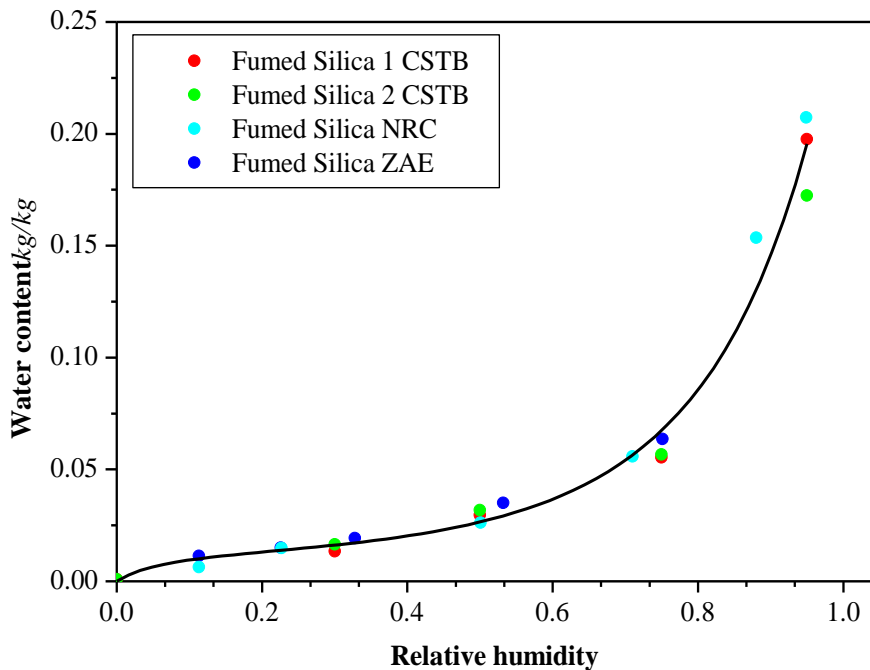


Figure 41: Sorption isotherm for fumed silica core determined by different institutes. For a relative humidity of 70% up to 5% in mass of water is adsorbed by the huge inner surface of about 200 m<sup>2</sup>/g (Simmler et al., 2005).

In the mid of the 1990s developments of VIP with organic foam as core material (polystyrene and polyurethane) for the application in refrigerators and freezers were going on. It proved that gases released from the inside of the panel together with gases permeating through the barrier laminate need to be captured inside the VIP. Getters for oxygen, nitrogen, CO<sub>2</sub> and hydrocarbons are required. Typically, getters fulfilling the requirements are very reactive at ambient conditions. To be able to handle them, chemical predecessors are used. After evacuation of the devices, e.g. formerly cathode ray tubes for TVs, they were thermally activated from outside at temperatures typically above 500°C. As the organic foams as well as the barrier laminates don't stand these high temperatures, a different approach was developed by the Italian company SAES GETTERS S.p.A. with their concept of the COMBOGETTER® (Manini, 1999b; Kullberg & Bradley, 2012).

The active getter is placed in the middle of a metal cup, surrounded by several millimetres of a chemical desiccant (CaO or BaO). This encapsulation provides twice:

1. a fairly amount of desiccant which captures even larger amounts of water vapour - especially for polyurethane foam it proved to be necessary - and protected the internal getter from saturation just by water vapour,

2. it reduced the velocity for the transport of dry gases to the inner of the capsule significantly.

Thus, a handling time for its integration into the VIP and the evacuation of several minutes was achieved. Before that the getter capsules were stored under argon atmosphere.

For getters and desiccants safety and environmental concerns must be considered.

A last remark: Considering the elongation of the life time of VIP by using getters. Even if there might be adequate and sufficient getters and desiccants to capture even larger amounts of gases, the limit is given by argon. There is no practical approach to capture noble gases. Assuming in a simple first-order approximation the same permeation rate for all dry gases, thus an amount of about 1% of argon in the atmospheric air limits the potential of getters (and desiccants) by a factor 100.

## 4.5 Characterisation Methods for VIP

This section describes the state-of-the-art of the characterisation methods related to the thermal performance of VIP.

Method		Responsible	Supportive Participants			Status	To Do	
Thermal Properties	Thermal Conductivity	Guarded Hot Plate	EMPA	Isover Saint Gobain	Paul Sabatier University	First draft from FIW, some comments from EMPA	Review	
		Vacuum Guarded Hot Plate				No team so far	Work out Guideline	
		Heat Flow Meter	POLITO	CRM Group	CSTB	Hanita	Extensive version submitted	Review
		Hot Disk	DLR	Kongju Uni	MATEIS, INSA Lyon		Extensive version submitted	Review
		Hot Wire	Kongju Univ	CSTB	MINES ParisTech		Two separate versions submitted by Kongju and CSTB	merge two version to one final guideline and review.
		Hot Disk - Vacuum	KTH				Version submitted	Review
	Specific heat capacity	Hot Strip	KTH				Version submitted	Review
		DSC	CSTB	Chalmers	EDF		Two separate versions submitted by CSTB and EDF	merge two version to one final guideline and review.
Porosity Properties	Density	Skeleton	Recticel	EMPA	MATEIS, INSA Lyon	incomplete draft	Review	
		Granular - 3D X-ray tomography	EMPA	EDF	MATEIS, INSA Lyon		Extensive version submitted	Review
		Granular - Hg picnometry	EMPA	EDF	MATEIS, INSA Lyon		Extensive version submitted	Review
		Granular - water pycnometry	EMPA	EDF	MATEIS, INSA Lyon		Extensive version submitted	Review
		Apparent	MINES ParisTech	Evonik	va-Q-tec		Version submitted	Review
	Porosity / average pore diameter	Hanita	DLR	EDF	MATEIS, INSA Lyon		Version submitted	Review
	Specific Area	DLR	Evonik	KTH	MINES ParisTech		Extensive version submitted	Review
	Pore Size Distribution	MATEIS, INSA Lyon	DLR	EMPA	MINES ParisTech	Outstanding	Work out Guideline	
	Solid morphology and size distribution	MATEIS, INSA Lyon	DLR	EDF	EMPA	Outstanding	Work out Guideline	
	Water sorption	Evonik	CSTB	LEPMI			Extensive version submitted	Review
Envelope Properties	Permeance	Adsorption	Recticel			Outstanding	Work out Guideline	
		Desorption	LEPMI			Outstanding	Work out Guideline	
	Diffusion	Manometry	LEPMI	EDF	Fraunhofer IVW	Metra Grou	Version submitted	Review
		VIP in climatic chamber	va-Q-tec	Hanita	KTH		Outstanding	Work out Guideline
	Solubility	Fraunhofer IVW				Outstanding	Work out Guideline	
	Activation Energies	LEPMI	EDF			Version submitted	Review	
Modeling Methods	Film	Impact of coating defects on film/barrier permeance				No team so far	Work out Guideline	
		Hygrothermal approach	EDF	MATEIS, INSA Lyon			Finalized	-
	Component	Pure thermal approach	EDF	MATEIS, INSA Lyon			Finalized	-
		Raw material approach	EDF	MATEIS, INSA Lyon			Finalized	-
		Wufi	POLITO				Finalized	-
	System	Cmsol	KTH				Finalized	-
		Building	Impact of the insulation system on the building thermal performance	Kongju Uni				Finalized
Ageing Method	Ageing under complex conditions	Accelerated ageing test in climatic chamber	POLIMI				Finalized	-
		Accelerated climatic strains	University of Perugia				Finalized	-
		Accelerated light and water exposure	University of Perugia				Finalized	-
	Ageing under severe conditions	Barrier	LEPMI	Hanita	Metra Group	va-Q-tec	Version submitted	Review
		Degradation of laminate	va-Q-tec	Kongju Uni	LEPMI		Outstanding	Work out Guideline
		Conductivity evolution	Evonik				Finalized	-

Figure 42: Characterisation Methods available among the Annex65 partners Status Dec. 2015

### **4.5.1 Thermal Conductivity**

As described in chapter 2.3 thermal bridges at the edges have large influence on the overall performance. Before coming to the experimental approach to determine the global performance, including thermal bridges (see 4.5.1.3), methods to determine the thermal transmittance in the undisturbed area are described in the following.

#### **4.5.1.1 Guarded Hot Plate Method**

This method defines the steady-state heat transfer through flat slab specimens and the calculation of its heat transfer properties. Thereby the heat transfers through radiation, conduction (solid and gas phase) and convection are considered. However, the separation is a difficult task.

#### **Description of functional principle according to ISO 8302:**

The guarded hot plate apparatus (GHP) is intended to establish within specimens, in the form of uniform slab(s) having flat parallel faced, a unidirectional uniform density of heat flow-rate at steady-state conditions as the one that would exist in an infinite slab bounded by two flat parallel isothermal surfaces. This is an absolute or primary method of measurement of heat transfer properties, since only measurements of length; temperature and electrical power are required.

From this basic principle, two types of guarded hot plate apparatus are derived:

- Two specimens with central heating plate (two plate apparatus) usually taking into account the gravity effects on the heat flow (convective part) as a mean value of upward and downward heat flow.
- Single specimen (one plate apparatus)

In the two specimen apparatus a central round or square flat plate assembly consisting of a heater and metal surface plates is installed (called the heating unit (C)), which is sandwiched between two nearly identical specimens (B1 and B2). The heat flow rate is transferred through the specimens to separate round or square isothermal flat assemblies called the cooling units (A) (see Figure 43).

The heating unit consists of a separate metering section, where the unidirectional uniform and constant density of heat flow-rate can be established, surrounded by a guard section (D) separated by a narrow gap. The cooling units may consist of a continuous flat assembly, but it is preferable to have them in a similar form to the heating unit.

With establishment of steady-state (thermal equilibrium) in the metering section, the density of heat flow-rate is determined from measurement of the heat flow rate  $\Phi$ , and the metering area  $A$ , that  $\Phi$  crosses.

The temperature difference across the specimens,  $\Delta T$ , is measured by temperature sensors fixed at the surfaces of the metal plates and/or fixed to the surface of the specimens where possible.

The thermal resistance  $R$  is calculated from a knowledge of  $\Phi$ ,  $A$  and  $\Delta T$ :

$$R = \frac{T_1 - T_2}{\Phi} A \quad (31)$$

The mean thermal conductivity  $\lambda$  of the specimen may also be computed if the thickness  $d$  of the specimen is measured.

$$\lambda = \frac{d}{R} \quad (32)$$

Tests can be conducted at various mean temperatures and in vertical and horizontal position. Normal mean temperatures for building products range between 0°C and 50°C, but different boundary conditions for specific investigations are also possible. The measurement method can be carried out for the whole temperature range where insulation products are used (e.g. from -180°C to +900°C). For higher temperatures, other measurement methods have to be used.

### Illustration of functional principle:

#### Determination of thermal conductivity with Guarded Hot Plate:

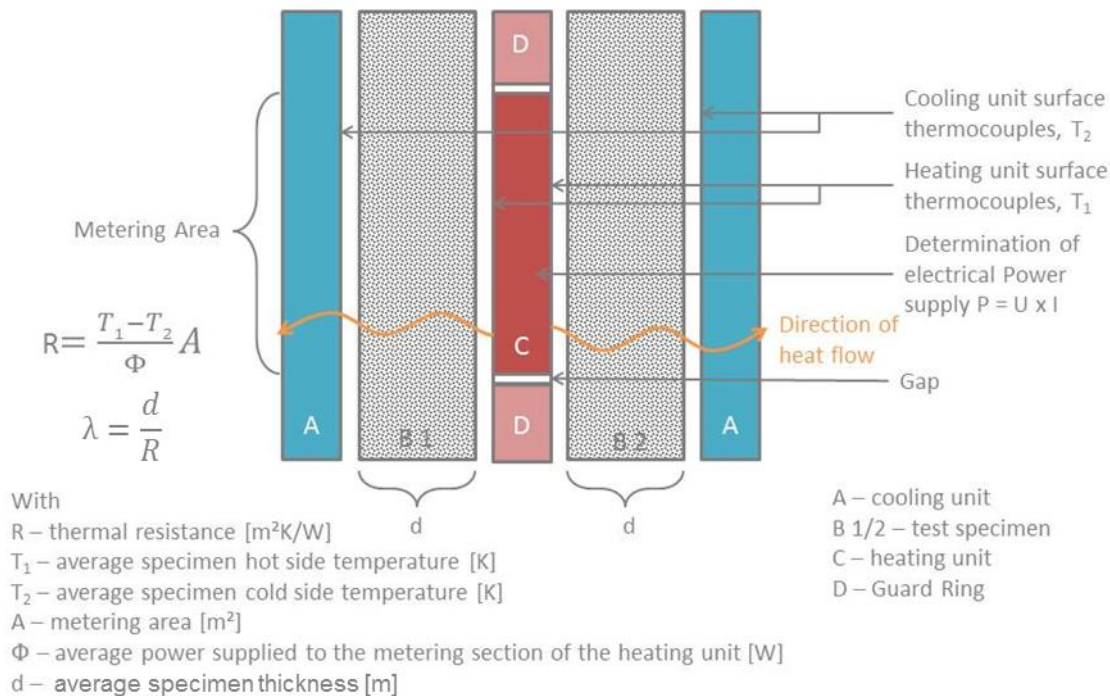


Figure 43: Principle of test method and determination of thermal conductivity value.

#### 4.5.1.2 Heat Flow Meter Method

This method defines the steady-state and transient heat transfer through flat slab specimens and the calculation of its thermal properties (resistance and conductivity). The method defines the global heat transfer through the specimen and does not allow to evaluate the contribution of solid and gas phase thermal conduction, radiation and convection.

##### Description of functional principle

The heat flow meter (HFM) apparatus is mainly based on digital thickness measurements, responsive temperature control and heat flow transducers electrical power measurements. The main purpose of the experimental method is the evaluation of the thermal properties (thermal conductivity or resistance) for the tested materials, through the measurement of heat flow density. This heat flow density is measured by means of one or two heat flow meter(s) placed against the specimen(s). The HFM is composed by a heating unit, one or two heat flow meters, one or two specimens and cooling unit (see Figure 44).

Samples must have flat parallel faces, to be inserted between two plates in the test stack. The plates may be positioned in an automatic way in contact with the specimen (exerting always the same pressure on the sample faces), or to a user-defined thickness. Plates are set with different temperatures (generating a temperature gradient) generating a heat flux through the specimen proportional to its thermal resistance. The heat flux transducer provides a reliable representative measurement of the total heat flow, integrating it over the entire measuring area of the plates (area where sensors are placed). The same thermocouples are also used for the control of the temperature of the heating and cooling plates.

Several apparatus configurations are available: single-specimen configuration (with single or double heat flow meter configuration) and two-specimen configuration.

In case of specimens characterised by high thermal resistance, the single specimen configuration is adequate. Otherwise, for low-resistance materials, the two-specimens' configuration is the best suited solution (ISO 8031:1991).

For this reason, in case of SIMs the most frequent configuration is the single specimen (symmetrical or not).

The following procedure is specific for single-specimen configuration: for the other cases see ISO 8031:1991 and EN 12667:2001.

The general measuring method is based on the one-dimensional Fourier-Biot law:

$$q = -\lambda \left( \frac{\Delta\vartheta}{s} \right) \quad (33)$$

where  $q$  is the measured heat flux density through the sample [ $\text{W}/\text{m}^2$ ],  $\lambda$  is the sample thermal conductivity to be determined [ $\text{W}/(\text{m K})$ ],  $s$  the sample thickness [ $\text{m}$ ] measured by the apparatus and  $\Delta\theta$  the temperature difference across the specimen [ $\text{K}$ ]:

$$\Delta T = T_{hot} - T_{cold} . \quad (34)$$

The temperature field in the sample should be considered uniform within all the sample's volume. This is due to the following reasons:

- The apparatus plates are isothermal (uniform one-dimensional temperature field);
- Size of the plates much larger than thickness of the sample.

The HFM apparatus must be calibrated through the test of reference certified sample materials (standard) with reliable known values of thermal conductivity  $\lambda_{cal}$  [ $\text{W}/(\text{m K})$ ], before measurements of materials with unknown thermal properties.

The specific heat flux  $q$  [ $\text{W}/\text{m}^2$ ] is proportional to the electric signal from the transducer  $E$  [ $\mu\text{V}$ ]:

$$q = \frac{\lambda_{cal}(T_{cal}) \cdot \Delta T_{cal}}{s_{cal}} = f_{cal}(T_{cal}) \cdot E . \quad (35)$$

The physical properties of the transducer change with temperature, for this reason calibration standard is always necessary for the calibration of the instrument and get the temperature dependent to calibration factor  $f_{cal}(T)$  [ $\text{W}/(\text{m}^2 \mu\text{V})$ ]. The calibration factors should be referred to the transducers actual temperatures (each transducer has its own temperature and so separate sets of the calibration factors are measured).

The calibration factors  $f_{cal}(T)$  represent a characteristic of the device. They are used for the evaluation of the thermal conductivity during the test run:

$$\lambda_{test} = \frac{f_{cal}(T_{test}) \cdot E \cdot s_{test}}{\Delta T_{test}} = \frac{q \cdot s_{test}}{\Delta T_{test}} . \quad (36)$$

Because of each plate has its own temperature, the calibration factors should be calculated for plate's actual temperature: the result of thermal conductivity test is obtained by averaging two thermal conductivity values.

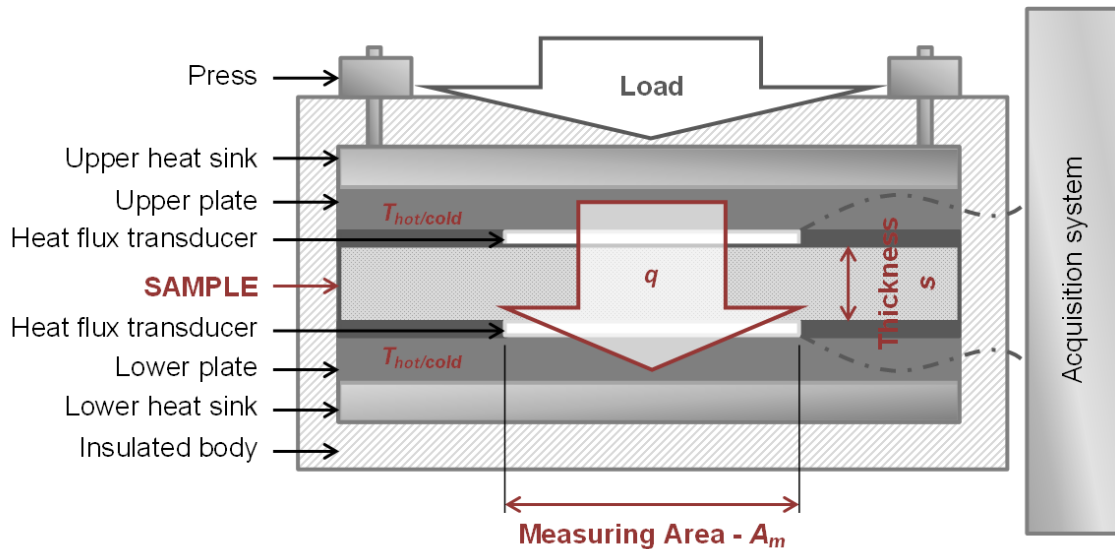
Before determining the results, the two heat flow meter signals have to reach equilibrium (experimental check demonstrated that equilibrium is reached faster in case of average value of two heat flow meter measures than in case of their individual values).

When stable conditions are reached, the heat flux  $\Phi_{test}$  over the centre measurement area,  $A_m$  [ $\text{m}^2$ ] is measured.

The thermal resistance of the panels is then determined as (according to EN 12667:2001):

$$R_{test} = \frac{\Delta T_{test}}{\Phi_{test}} \cdot A_m = \frac{\Delta T_{test}}{f_{cal}(T_{test}) \cdot E} . \quad (37)$$



**Illustration of functional principle:**


$$\lambda = \frac{f_{cal}(T) \cdot E \cdot s}{\Delta T} = \frac{q \cdot s}{\Delta T} \quad R = \frac{\Delta T}{\Phi} \cdot A_m = \frac{\Delta T}{f_{cal}(T) \cdot E}$$

Where:

- $T_{hot}$  and  $T_{cold}$  are the set-point temperatures of the two plates [K];
- $\Delta T$  is the temperature difference between the plates [K];
- $q$  is the specific heat flux through the sample in measuring area [ $W/m^2$ ];
- $A_m$  is the measuring area of the heat flux transducers [ $m^2$ ];
- $R$  is the thermal resistance of the sample [ $m^2K/W$ ];
- $s$  is the sample thickness [m];
- $\lambda$  is the sample thermal conductivity [ $W/m/K$ ];
- $E$  is electric signal from the transducer [ $\mu V$ ];
- $f_{cal}(T)$  is the calibration factor [ $W/m^2\mu V$ ].

Figure 44: HFM Apparatus and test specimen, vertical section. Principle of test method and determination of VIP thermal conductivity value,  $\lambda$ .

**Anisotropic specimens**

Some specimens are characterised by different thermal conductivity values if measured in a direction parallel to the surfaces or normal to the surfaces. In the cases, when the ratio between the two measurable thermal conductivity values is larger than two, as it is e.g. for glass-fibre VIP, the ISO 8302:1991 standard must be consulted.

**4.5.1.3 Experimental approach to determine the overall thermal performance**

The first step is to measure the thermal conductivity in the centre of panel  $\lambda_{COP}$  in a GHP or HFM apparatus and calculate the thermal transmittance in the undisturbed area  $U_0$ . Then the thermal bridging effects for the edges of the panels have to be added by their linear thermal transmittance  $\psi$  and their length.

Direct determination is possible by measurement of  $U_{eff}$  in a hot box or by measuring  $R_{eff}$  in a GHP or HFM apparatus. The differences are obvious: when numerical simulations are used, all effects can be determined separately (e.g. different edge designs, gasket strips or adhesive tapes). When using Hot-Box measurements, 2- and 3-dimensional effects can be considered, but only in total. It is not possible to determine single effects, but the thermal performance can be measured directly. When using GHP or HFM measurements, the same limitations as for Hot-Box measurements apply and additionally these measurements can only be used to measure 2-dimensional effects.

$$\lambda_{eff} = \frac{d_{panel}}{\frac{1}{U_{eff}} - R_s} \quad \text{or} \quad \lambda_{eff} = \frac{d_{panel}}{R_{eff}} \quad (38)$$

where

- $\lambda_{eff}$  equivalent thermal conductivity for a VIP including 2- and 3-dimensional thermal bridging effects in W/(m K),
- $d_{panel}$  thickness of the VIP in m,
- $R_s$  sum of internal and external thermal resistances at the surfaces of the panel in  $m^2 \cdot K/W$ ,
- $R_{eff}$  thermal resistance of the VIP including thermal bridges – taken from a measurement of a joint assembly in  $(m^2 \cdot K)/W$ .

If  $U_{eff}$  is determined by measurement of a joint assembly in a GHP or a HFM apparatus from  $R_{eff}$  the cold-side and warm-side surface resistances are negligible. The term  $R_s$  in equation can be omitted.

#### **4.5.1.4 Transient Methods for the Measurement of the Thermal Conductivity**

##### **Hot Disk Method**

The transient plane source technique (“Hot Disk”) is based on measuring the sample behaviour in the transient regime of heat flow. During measurement, a current passes through the nickel spiral of the sensor and creates an increase in temperature. The heat generated dissipates through the sample on either side at a rate dependent on the thermal transport characteristics of the material. By recording the temperature-versus-time response in the sensor, two properties, thermal conductivity and the thermal diffusivity, can be calculated.

**Illustration of functional principle:**

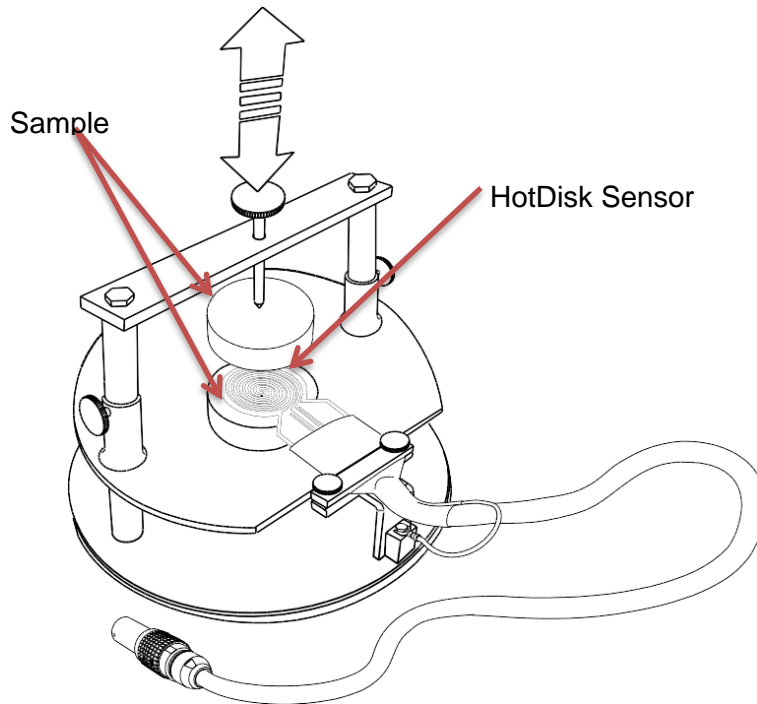


Figure 45: Room temperature sample support (International-Organization-for-Standardization- (ISO), 2008).

**Description of functional principle**

According to ISO 22007-2:

A specimen containing an embedded hot disk probe as shown in the Figure 45 and Figure 46 of negligible heat capacity is allowed to equilibrate at a given temperature. A heat pulse in the form of a stepwise function is produced by an electrical current through the probe to generate a dynamic temperature field within the specimen. The increase in the temperature of the probe is measured as a function of time. The probe operates as a temperature sensor as well as a heat source (i.e. a self-heated sensor). The response is then analysed in accordance with the model developed for the specific probe and the assumed boundary conditions. Setup, a picture of the probe and the position of the sensor are drafted in Figure 45 and Figure 46.

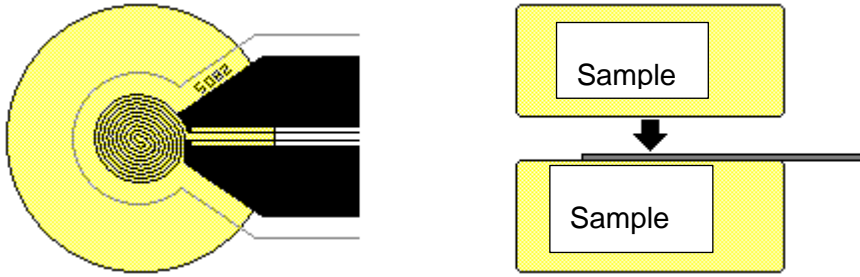


Figure 46: Sensor position between sample pieces (Hot Disk AB, 2013) .

The hot disk utilizes a sensor element in the shape of a double spiral which acts both as a heat source for increasing the temperature of the sample and a resistance thermometer for recording the time-dependent temperature increase of the heat source itself. Usually, the sensor element is made of a 10  $\mu\text{m}$  thick nickel-metal double spiral, which is supported by a material (polyamide or Mica) to protect it, give it mechanical strength and keep it electrically insulated. The encapsulated Ni-spiral sensor is then sandwiched between two halves of the sample.

The theory assumes that the hot disk consists of a certain number of concentric ring heat sources located in an infinitely large sample. If the hot disk is electrically heated, the increase in its resistance as a function of time will be recorded and can be given as:

$$R(t) = R_0[1 + \alpha \cdot \Delta T(t)] \quad (39)$$

where

$\Delta T(t)$  mean temperature increase of the probe;

$R_0$  initial resistance of the probe at temperature  $T_0$ ;

$\alpha$  temperature coefficient of resistance (TCR) of the probe.

The temperature increase can be seen as a sum of increase in temperature over the insulating layers of the probe  $\Delta T_i(t)$  and increase in the temperature of the specimen surface  $\Delta T_s(t)$ .

The thermal conductivity can be calculated with:

$$\Delta T_s(\tau) = P_0 \left( \frac{3}{\pi^2 r \lambda} \right)^{-1} D(\tau) \quad (40)$$

where

$P_0$  power output of the sensor;

$r$  radius of the outermost ring source;

$\lambda$  thermal conductivity of material;

$\tau$  is defined as

$$\tau = \left(\frac{t}{\theta}\right)^{1/2} \text{ where } \theta = \frac{r^2}{\alpha}$$

$D(\tau)$  dimensionless specific time function.

By making a computational plot of the recorded temperature increase versus  $D(\tau)$ , a straight line is obtained, from which the thermal conductivity is calculated through a process of iteration (see Figure 47). In this way, it is possible to determine both the thermal conductivity and the thermal diffusivity from one single transient recording.

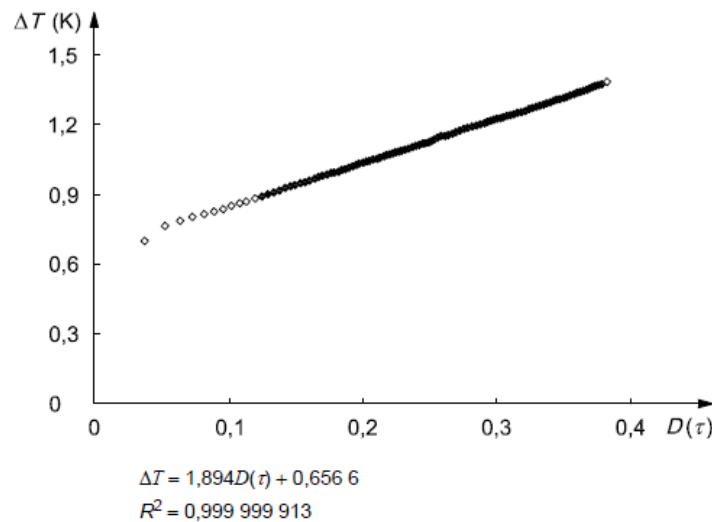


Figure 47: Temperature increase versus  $D(\tau)$  [ISO 22007-2] (International-Organization-for-Standardization-(ISO), 2008).

## Hot Wire Method

This method covers determination of thermal conductivity  $\lambda$  of isotropic materials; principal heat transfer through radiation, conduction (solid and gas phase) and convection are considered.

### Description of functional principle

According to ASTM C1113 and ISO 8894-2. The apparatus consists of the following main parts:

- The control unit: made up of (a) a programmable power supply which is capable of generating electrical power for the heating needle (lead wire) and analyses the temperature increases, and (b) a computer capable of controlling the operation of the power supply.

- The probe which is formed of two main components: the heating needle (lead wire) and the thermocouple (installed to measure sample temperature) (see Figure 48).

**Illustration of functional principle:**

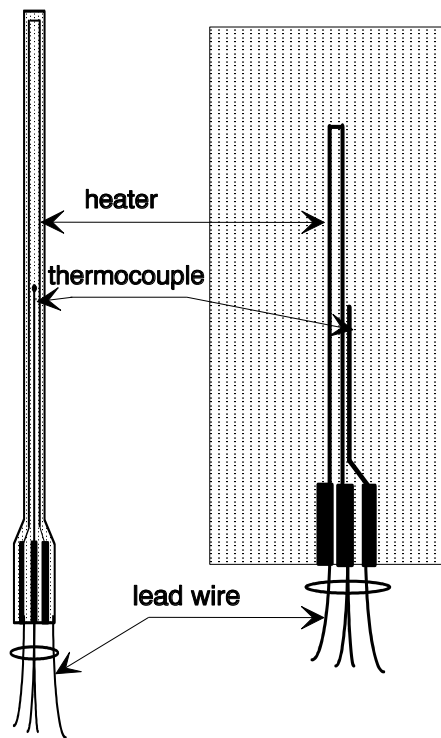


Figure 48: Thermal probes.

**Hot Strip Method**

Several methods have recently also been developed for transient measurements of thermal conductivity ( $W/(m \cdot K)$ ) as well as thermal diffusivity ( $m^2/s$ ) of low conductive materials, such as the transient hot bridge (THB) method, the transient line source (TLS) method as well as the transient plane source (TPS) method.

In this study, a commercially available silica aerogel and two newly developed precipitated silica “powders” are tested with independent transient measurement methods with a transient hot bridge (THB) method (Hot Strip) as well as with a hot disk (TPS) method.

**Description of functional principle**

The transient hot bridge (THB) method, used in this study, is based on the theory of transient temperature increase over a flat surface that also serves as a heat source. This

commercially available method is an enhancement of the transient hot strip method (DIN EN 993-14, DIN EN 993-15). The laboratory experiments with THB method were carried out in an “outside” laboratory of the Linseis Thermal Analysis Corporation. A combined heat source and a temperature sensor in the shape of a very thin strip, is embedded between two pieces of the sample material as shown in Figure 49.

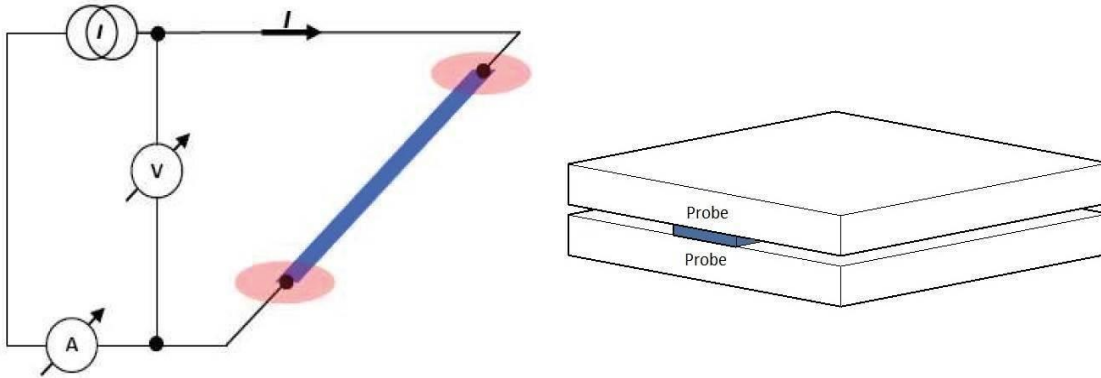


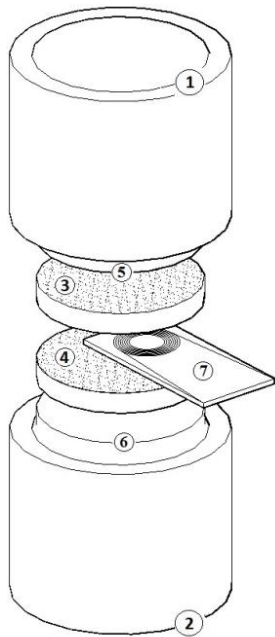
Figure 49: Method of the THB measurement while a strip shaped conductor as a heat source and a temperature sensor (at the left) embedded between two pieces of the same test sample (at the right).

The sensor (type B, size of 22 mm × 48 mm, THB6K7) is first calibrated with a resin-bonded glass fibre board (IRMM440) from the Institute for Reference Materials and Measurements (IRMM). By supplying a constant current to the metal strip, a constant heat flow can be emitted during the experiment while the strip also serves as a resistance thermometer. The temperature increase with time corresponds to the thermal transport properties of the test sample. The measuring time is generally typically 1 min and generally less than 10 min, depending on the thermal properties of samples. The measuring procedure is similar to that of the TPS method with both methods being based on the transient temperature increase caused by a heat supply over a flat surface, but the measurement probes are different. The measuring procedure of both the THB and the TPS method is described in detail, in following section.

The transient plane source (TPS) method is a modified version of the transient hot strip method. In the TPS technique (recognized in ISO 22007-2), a constant electric power is passed through a very thin (10 μm thick) double metal spiral while it fitted between two layers of 25 μm thick Kapton foil membrane. This sensor acts both as a heat source for increasing the temperature of the sample and as a “resistance thermometer” for recording the time dependent temperature increase. During the experiment, heat is generated in the coil. This causes the temperature to rise and an increase in the resistance of the spiral while the heat is absorbed by the test sample. As in the case of the THB method, the voltage across the “meander spiral” is registered during the measurement. The temperature rise can be related to the thermal transport properties of the surrounding materials. The rate of change in the registered voltage corresponds to

the resistance variation of the metal spiral when the electric power is held constant. The short time interval makes it possible to neglect the end effects of the finite size of metal strip and the temperature distribution around and in the coil is identical to that of an infinitely long plane heat source.

This is done by applying the thermal analyser software for the TPS 2500 S system (ISO/DIS 22007-2.2) that incorporates tools for automated measurements as well as automatic temperature control of external devices. The transient laboratory



measurements were carried out with a TPS 2500 S thermal conductivity instrument (ISO/DIS 22007-2.2). According to the manufacturer, an accurate measurement for both, the thermal conductivity  $\lambda$  (W/(m K)), and thermal diffusivity  $k$  (m<sup>2</sup>/s), can be obtained for a wide range of temperatures (from cryogenic up to 1000 K). The TPS instrument is connected to a self-designed device (Figure 50) capable of performing thermal conductivity measurements at different sample densities. The device consists of two Plexiglas cylinders with 15 mm thick walls and an inner diameter of 60 mm, while each cylinder has a piston of Plexiglas with an outer diameter of 59.1 mm in order to keep the powder in place. The gap between the cylinder and the piston is sealed with 2 mm thick sealing rubber rings. Figure 50 shows the TPS sensor connected to the self-designed device.

Figure 50: The structure of self-designed device for performing the transient thermal test on silica powder by TPS method. (1) and (2) are the upper and lower cylindrical vessels filled up by (3) and (4) which are silica materials to be measured, (5) and (6) are the upper and lower sample holders (Plexiglas pistons) which were used for keeping the powder in place, and (7) is the TPS spiral sensor embedded between same samples.

#### 4.5.2 Internal Gas Pressure

The foil lift-off technique is the most commonly used method or procedure used by manufacturers to determine the internal gas pressure of VIPs during and after the production process. The lift-off technique is used in two versions for measuring the internal pressure of VIPs:

1. The suction bell method on a small section of a VIP envelope,
2. the evacuation chamber method on a whole VIP.

Both methods make use of one or more laser distance measuring device(s) that measure the distance to the surface of the foil while constantly evacuating the surrounding - the space under the suction bell for method 1 and the whole evacuation chamber for method 2. The level of vacuum for the pressure compensation method is shown to work in the



range from 0.2 to about 100 mbar with membrane type pressure sensors for the range from 0 to 100 mbar.

### Suction bell:

The equipment consists of a top and bottom suction bell. In one of the half-spheres, a laser distance meter is implemented. Usually this is the upper half-sphere. The edges of the half-spheres are connected to the surface of the VIP and sealed. Usually an active vacuum ring-seal is used.

### Vacuum chamber:

The vacuum chamber method is to be seen as the reference method, due to higher accuracy compared to the suction bell method. A principle sketch is shown in Figure 51. The system measures internal pressure by using the panel envelope laminate as the measurement membrane. The specimen is placed in a vacuum chamber, which is then evacuated. The system records automatically the decreasing pressure surrounding the panel and the displacement of the envelope when the external pressure surrounding the panels approximately gets to the internal pressure inside the panel. The pressure inside the vacuum chamber at which the envelope starts to move away from the core is considered to be equal to the internal pressure inside the VIP. Several cycles of reduction of pressure until lift-off of the foil are performed to be sure that no adhesive effects between the core-material, fleece-liner and the foil itself are influencing the measurement results.

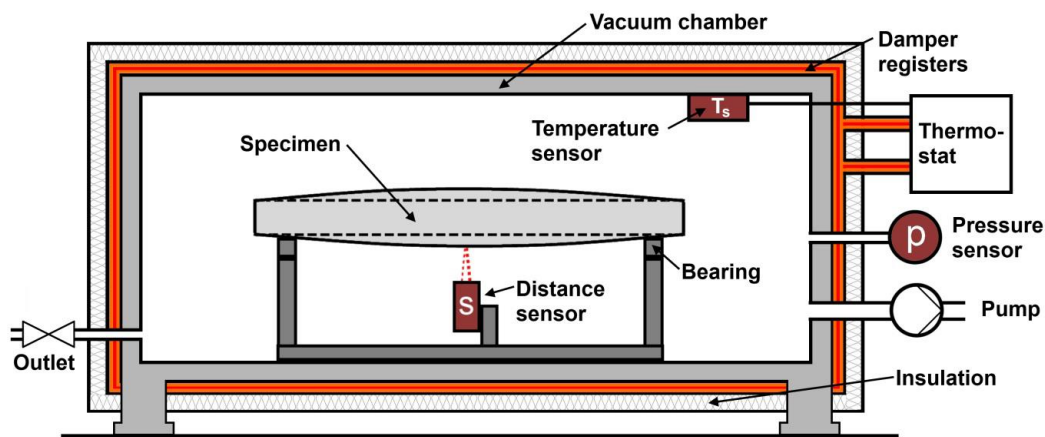


Figure 51: Principal sketch of the measurement device in a vacuum chamber - linear bearings, temperature and distance sensor (laser device) (illustration FIW).

### Evaluation methods:

For data evaluation, the movement of the surface of the foil  $s$  is plotted as a function of distance over internal pressure  $p_{i,c}$  of the vacuum chamber  $s(p_{i,c})$ . Basic algorithms for data analysis have been developed for the further processing of the distance

measurement results into the internal pressure results. The methods can be implemented with any adequate script language.

Separate analysis of parts of the measurement data each containing a lift-off sequence between the short-duration ventilations of the vacuum chamber is conducted for both available methods. In Figure 52 for the low pressure region below 4 mbar measured data on one single lift-off sequence is shown.

A certain value inside the bent transition zone is assumed to represent the existing internal pressure.

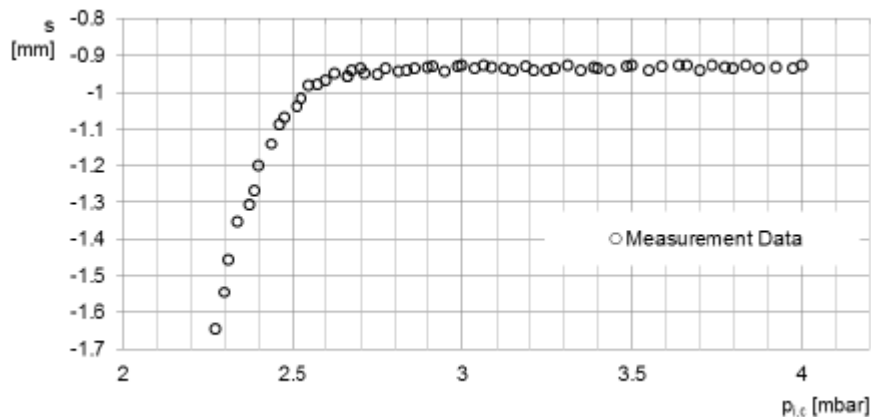


Figure 52: Raw data of the distance  $s$  between laser measuring gauge and the VIP surface as a function of the internal pressure of the chamber  $p_{i,c}$  determined on a VIP with 15 mm thickness, sample rate 1 Hz (illustration FIW).

### 4.5.3 Long Term Performance of VIP

#### Degradation effects

Gas permeation through the film and the sealing result in an increased gas pressure ( $O_2$ ,  $N_2$ ) and water vapour pressure (depending on type of film). Driving forces for both, dry air and water vapour permeation, are the differences in the partial pressures inside and outside. The core material of the VIP and (if added the getter and/or desiccant) determine the absorption of permeated gas and water vapour. Absorbed water is discussed to increase the solid conductivity of the matrix by adsorption especially at the necks most sensitive to the heat transfer along the solid skeleton (Schwab et al., 2005a; Beck & Binder, 2008; Heinemann, 2008). This effect is reversible. There are hints for an additional effect, which is assumed to be caused by an irreversible intensification of the joints of particles (Brunner & Ghazi Wakili, 2014) accompanied with a decrease of inner surface (Collins et al., 2008).

#### Ageing procedures

#### Scope and limits of application

An accelerated ageing is limited to the weakest part/property of each insulation material, for example the glass transition temperature (softening), the degradation temperature (e.g. of the hydrophobisation or the binder) or the delamination temperature of the film.

#### **Accelerated ageing in climatic chamber**

The climatic chamber simulates the outdoor weathering condition, including rain, freeze, humid heat, dry heat without UV, and UV radiation. It can be used to reproduce the ageing effects of outdoor climatic condition on insulation materials, with or without finishing layers, placed inside the chamber.

Alternatively a test wall (1.0 m x 1.0 m approximately) can be reproduced, placed with a frame as the door of the climatic chamber, reproducing the outdoor condition inside the chamber and the indoor condition in the laboratory. A set of sensors can be installed for monitoring temperature, humidity and heat flux on the surface and at different thickness of the cross section of the wall.

A set of destructive and non-destructive tests at different steps of ageing can be carried out on the aged samples.

#### **Accelerated climatic strains**

The method seeks to simulate the natural climatic strains, consisting in UV radiation, water, frost, and temperature changes. Its objective is to concentrate the individual climatic factors so that, in total, they produce a cycle of strains giving degradation results similar to natural exposure but in a much shorter period of time.

The method has been applied to study the degradation of vertically positioned materials and components in the building envelope (NT BUILD 495) and of horizontal roof waterproofing materials (EN 1297).

The test specimens are mounted in a manner that best simulates the service conditions and so that they are not exposed to other strains than those existing in practice. Test specimens exposed simultaneously must not be able to influence each other. Any signs of degradation e.g. cracks, loss of gloss, delamination, etc. during exposure are noted.

For horizontal samples, the test specimen racks shall allow the specimens to lie flat in the plane  $\geq 5^\circ$  above the horizontal and to be mounted so that the exposed face is in the plane of uniform irradiance.

#### **Accelerated light and water exposure**

The method seeks to simulate the deterioration caused by sunlight and water as rain or dew. The method could be applied to non-metallic materials (ASTM G151, ASTM G152, ASTM G154, ASTM G155 standards). Moreover, it could be specifically applied to plastics (ISO 4892-1, -2, -3 and -4 standards).

The test specimen prescriptions (form, shape and preparation) are described in ASTM G151:2010 and ISO 4892-1. The methods used for the preparation of test

specimens can have a significant impact on their apparent durability. Therefore, the interest parties shall agree upon the method used for the specimen preparation. It should preferably be closely related to the method normally used to process the material in typical applications. The description of the preparation method should be included in the final test report.

The dimensions of the test specimens are normally those specified in the appropriate test method for the properties to be measured after exposure. In some cases, individual specimens used for property measurement may need to be cut from a larger specimen, which has been exposed. In this case, it is necessary to follow the ISO 2818 for preparation of test specimens by machining. When test specimens are cut from a larger sample, they should preferably be taken from an area that is at least 20 mm from the exposed specimen edges.

When comparing material in an exposure test, test specimens that are similar in dimensions and exposed area must be used.

#### **4.5.4 Round-Robin Tests**

Within a German government-funded project (Heinemann et al., 2007), beside many others, also a round-robin test on 9 VIP was performed. Measurements were performed at the beginning and after 1 year of ageing. 3 of the 9 panels were stored under accelerating ageing conditions (80°C, r.h. < 5%).

Three partners contributed: FIW Munich and ZAE Bayern, both using guarded hot plate devices, testing at a mean temperature of 10°C, and the company va-Q-tec using two different heat flow meter devices, testing at 46.5°C resp. 15.5°C.

Within several months, panels first were tested at ZAE and va-Q-tec, and then at FIW. Then for 1 year, the panels were stored under controlled conditions at FIW. Two different climates were chosen for three groups of panels (see Table 7). Afterwards within one months all partners again tested the panels, first FIW and then ZAE and va-Q-tec. Additional intermediate tests every 3 months were performed by FIW.

Table 7: Conditions of storage.

Panel no.	temperature / r.h.	remark
001, 002 and 003	23°C / 80%	
004, 005 and 006	80°C / <5%	
007, 008 and 009	23°C / 80%	additional dryer added to the panels

In order to avoid uncertainties in the determination of the thickness, a comparison of the primary determined property 'heat transfer coefficient' was chosen. The results gained by ZAE and FIW prior and after ageing coincide far below the uncertainty ( $k=2$ , 95% interval of coincidence). Additionally, no systematic deviation could be observed, thus indicating an uncertainty that is even less than stated by both institutes.

Thus, it is not surprising that also the rates of increase gained by both institutes are quite close (see Figure 53). The results by the first device of va-Q-tec systematically are somewhat lower, probably caused by an inaccurate calibration factor. Those gained by the second device are quite closer to that of ZAE and FIW.

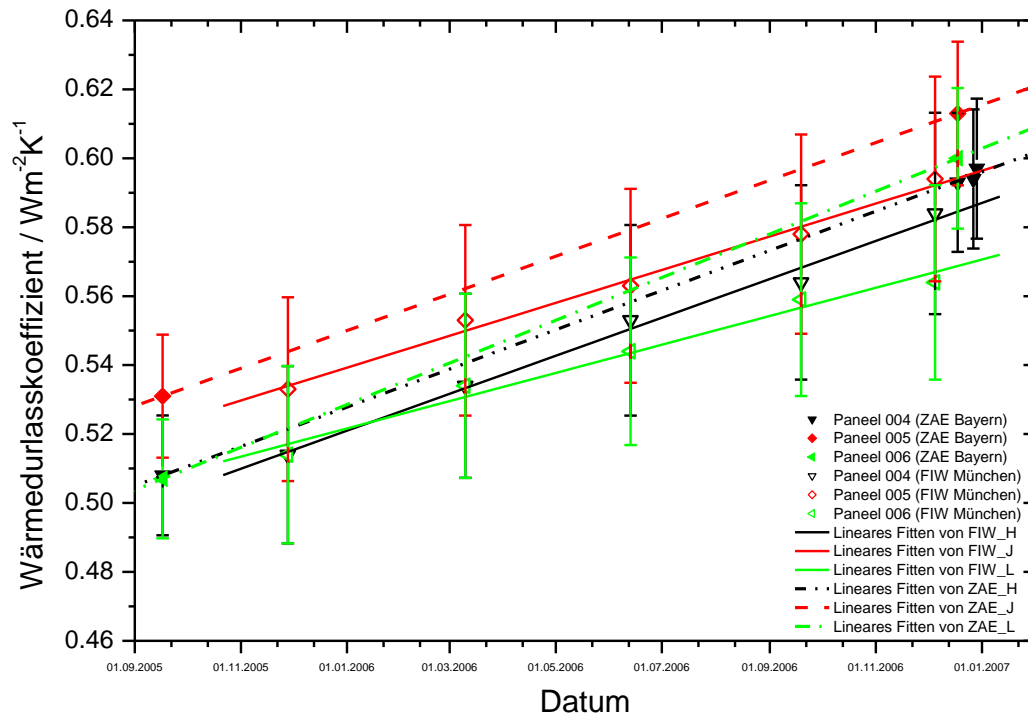


Figure 53: Measured heat transfer coefficient versus time. Between Dec. 2006 and Dec. 2007 the VIP were stored under accelerated ageing conditions at (80°C / r.h. < 5%). (Heinemann et al., 2007). Note: The zero point is suppressed.

## 4.6 Standardisation, Norms, Approvals, Certifications

The insulation performance of vacuum insulation panels is about five to ten times that of conventional insulation of the same thickness. Compared to standard insulation materials these elements are associated with some specific features:

- The size can't be adapted on the installation site.
- By cutting, puncturing etc. the benefit in thermal performance due to evacuation gets lost. The thermal conductivity may arise by a factor of up to 5 for fumed silica, by a factor of up to 20 for glass fibre cores when no longer evacuated.
- Thermal bridge effects must be considered even for the insulation elements it selves.
- The exchange of gases and gases penetrating inside yield a decrease of the insulation performance (ageing), which might be much larger; in the worst case by the factors given above. Under the aspect of long-term performance, a wide spread in the quality of VIP might be related especially to these effects.

For these unusual products thus special testing and assessment procedures were developed in different countries.

### 4.6.1 Canada

Canada does not have any approved standard for specifications or evaluation of vacuum insulation panels. Based on the laboratory and field observations an accelerated ageing test protocol and a methodology to predicting long-term thermal resistance of vacuum insulation panels have been proposed (Mukhopadhyaya et al., 2015).

### 4.6.2 China

In China in 2014 the Ministry of Housing and Urban-Rural Development of China issued the Building Industry Standard of China: JG/T 438-2014 "Vacuum Insulation Panels for Buildings".

According to this standard the thermal conductivity shall be measured in the centre of test specimen at average temperature of  $(25\pm 2)^{\circ}\text{C}$ . Prior to these measurements the specimens have to undergo a durability test and ageing procedure.

*"... Have 9 test specimens soaked in water for 1 d among which 3 are done with thermal conductivity test. Remove water on their surfaces by wet towel when they are taken out. Treat test specimens with 30 damp-heat/freeze cycles in high/low temperature damp-heat tester. Keep them under standard testing conditions for 2 d. Conditions of damp-heat and freeze treatment are as follows:*

- a) *Raise temperature to  $(70\pm 5)^{\circ}\text{C}$  relative humidity to  $(90\pm 5)\%$  within 1 h, and keep it for 3 h.*
- b) *Lower temperature to  $(-20\pm 5)^{\circ}\text{C}$  within 1 h, and keep it for 3 h.*

...”

There is no information on long-term behaviour and the effects of thermal bridging.

#### **4.6.3 Germany, France, Switzerland**

Several VIP products got a national approval for the use in buildings in Germany.

Beside others the testing procedure comprises following aspects:

- accelerated ageing at an elevated temperature in dry climate for half a year,
- several times thermal cycling,
- consideration of the thermal bridge effects for adjacent panels.

Based on scientific research from the accelerated ageing test the expected heat transfer for 25 years is calculated. Together with some add-on for safety this yields the value for the declared thermal conductivity  $\lambda_D$  for panels with minimum dimensions.

The procedures in France and Switzerland are quite similar. One difference in Switzerland is the way, how the effect of panel's size on the overall performance is considered. In Germany and France(?) pragmatically the smallest panels with the least dimension of e.g. 300 mm x 300 mm and thus largest relative influence of thermal bridging is considered. For larger dimensions thus, one is on the safe side. Switzerland follows the more sophisticated concept of centre of panel values and  $\psi$ -value for the thermal linear thermal transmittance of the edges. Thus, the effective thermal performance depends on the dimensions of a panel.

#### **4.6.4 European Union**

One has to distinguish between ETA in the meaning of an European Technical *Approval*, issued until 30<sup>th</sup> of June 2013, and ETA in the meaning of an European Technical *Assessment*, in force after 1<sup>st</sup> of July 2013 (ETA, 2017).

In accordance with the Regulation (EU) No 305/2011 (CPR), a manufacturer, when placing a construction product on the market, is responsible to provide a Declaration of Performance (DoP) for this product, when it is covered by a European Technical Assessment (ETA) issued for it.

A European Technical Assessment (ETA) is issued on the basis of a European Assessment Document (EAD), or ETAG used as EAD.

A European Technical Assessment (ETA) is a document providing information about the performance of a construction product, to be declared in relation to its essential characteristics. This definition is provided in the new Construction Products Regulation (EU) No 305/2011, which entered into force on 1<sup>st</sup> of July 2013 in all European Member States and in the European Economic Area. The ETA is valid in all 28 European Member States and those of the European Economic Area, as well as in Switzerland and Turkey.

The ETA provides the voluntary way for the manufacturer to CE-mark a construction product. The ETA can be issued, if

- the construction product is not or not fully covered by any harmonised European Standard (hEN) and
- the assessment methods and criteria are laid down in a European Assessment Document (EAD).

An ETA contains the following information:

- contact details of the manufacturer (ETA holder),
- the product (trade name) and its intended use,
- the manufacturing plant (encoded or contact details),
- details of the assessment programme and performances of the product, and
- depending on the relevant AVCP systems, the control tasks of a Notified Body or of the manufacturer.

An ETA which has been issued after 1st of July 2013 is valid of *indeterminate* duration. On the EOTA website references to issued ETAs are published.

ETAs, which are issued up to 30 June 2013 (so called European *Approvals*), remain valid until the end of their validity period. They can be used by manufacturers as European Technical Assessments. This type of ETAs will disappear from the market throughout the year 2018. These ETA approvals were based on ETA Guidelines or issued upon agreement of the Approval Bodies. As they were based on national procedures, differences, e.g. in the ageing test, lead to the unfortunate situation that the same product got different declared values for the thermal conductivity  $\lambda_D$  depending on national approval or ETA.

However, the general approach is common: for the declared thermal conductivity  $\lambda_D$  the influence of ageing and the effect of thermal bridges are considered as well as the size of the elements (minimum dimensions).

Moreover a product standard for VIP is currently drafted at CEN level. The goal is to have a harmonised product standard 2018 latest. The technical enquiry will be started in 2017. The approach is similar to the ETA one. Ageing and thermal bridges are taken into account in the declared thermal conductivity which will be size dependant.

#### **4.6.5 North America**

There are Standards in North America, both for APM, especially aerogel insulation, ASTM C1728 – 12, Standard Specification for Flexible Aerogel Insulation (ASTM C1728 – 12, 2012), as well as for Vacuum Insulation Panels, ASTM C 1484 – 10, Standard Specification for Vacuum Insulation Panels (ASTM C1484 - 10, 2010).

They are determined for general purpose, not especially formulated for building applications.

For the aerogel insulation possible ageing effects are not considered in this standard.

For VIP however, ageing due to outgassing and permeating gases are taken into account by: “*Service Life—The actual service life of a vacuum insulation panel is determined in*



*large part by: the panel design and materials, the service environment, and the minimum acceptable thermal resistance. The standard-condition service life is defined as the period of time for which the panel will provide superinsulation performance in an environment of 24°C and 50 % relative humidity. In making this determination, the manufacturer shall consider, at the stated standard environmental conditions, the following: the outgassing of the filler material, the outgassing and permeability of the panel barrier material, the permeability of the edge seals, and the performance of any adsorbent materials contained within the panel. The expected decrease in thermal resistance that occurs as the vacuum insulation panel ages shall be measured or computed from the relationship between thermal resistance and internal VIP pressure (for the appropriate mixture of gasses)” (ASTM C1484 - 10, 2010). In the appendix as “Nonmandatory Information”, panel ageing calculations are described.*

The effects of thermal bridges by the panel barrier are considered in the effective thermal resistance of a full-size panel. Additionally, the effective thermal performance after puncture shall be determined.

#### **4.6.6 Japan**

Japanese national committee has discussed the industrial standard specification for Vacuum insulation panel (VIP) since 2014. In preparation for step-by-step regulation enhancement towards building energy efficient obligation act in 2020, the industrial standard of VIP has been developed at a fast pace. This draft contains not only VIP itself but also VIP composite product. It will be published as Japanese industrial standard in the near future.

Separately from the industrial standard specification for VIP, testing method for measuring the thermal performance of VIP has been established steadily. As for thermal resistance of centre of panel for VIP with Guarded hot plate apparatus, related measurement procedure and notes are added into JIS A1412-1: “Test method for thermal resistance and related properties of thermal insulations – Guarded hot plate apparatus” as appendix JC. Standard test method of thermal transmission properties for vacuum insulated building components is also prepared especially for test specimen with inhomogeneous or heterogeneous thermal performance. This standard refers to measurement procedure and remarks of VIP and VIP composite product with calibrated hot box method and will be published soon. Testing method for long-term performance over 25 years is discussed, too. Basic idea of Japanese National committee is similar as that of European committee except for seam part of envelop and getter. In case of vacuum insulation panels with laminated Al foil as envelop, air and moisture penetrate not through the film but through the seam part of envelop mainly. Desiccant and getter is essential for VIP with glass wool core in order to keep the long-term performance. The new standard for testing long-term performance will take the concept of seam length of envelop and getters into account.

#### 4.6.7 South Korea

No information available.

#### 4.6.8 An Example – Accelerated Ageing Test Protocol for CANADA

Based on laboratory tests, field performance test data and years of research experience, a team of researchers from Canada have recently proposed an accelerated ageing test protocol with performance requirements, as shown in Table 8 (Mukhopadhyaya et al., 2015). Furthermore, the VIPs satisfying thermal performance requirements outlined in Table 8 would be expected to have an ageing rate of 2% per year and minimum estimated thermal resistance retention after 15 years equals to about 70% of the initial thermal resistance value (Figure 54). For estimating the thermal resistance value of VIPs beyond 15 years of ageing, further investigation will be needed (Figure 54).

It is to be noted that the proposed accelerated ageing test protocol and prediction of the long-term thermal performance of VIPs are based on the available information and authors' experience with VIPs and other insulating materials. It is expected that the proposed test protocol and the performance requirements would be reviewed when more research and application outputs will be available in the coming years.

Table 8: Accelerated ageing test protocol and thermal performance requirements for VIPs.

No.	Ageing Conditions	Total Duration (days)	% R-value Reduction Requirement
1	70°C, 95%RH	30	≤ 20
2	95%RH, 22°C	90	≤ 10
3	90°C, ambient RH	90	≤ 10
4	-30°C, ambient RH	90	≤ 5
5	70°C (ambient RH), 95% RH (22°C) - Alternate	98 (1 week @ 70°C, followed by 1 week @ 95% RH (22°C) - 7 cycles)	≤ 10
6	-30°C (ambient RH), 50% RH (22°C) - Alternate	98 (1 week @ -30°C, followed by 1 week @ 50% RH - 7 cycles)	≤ 5

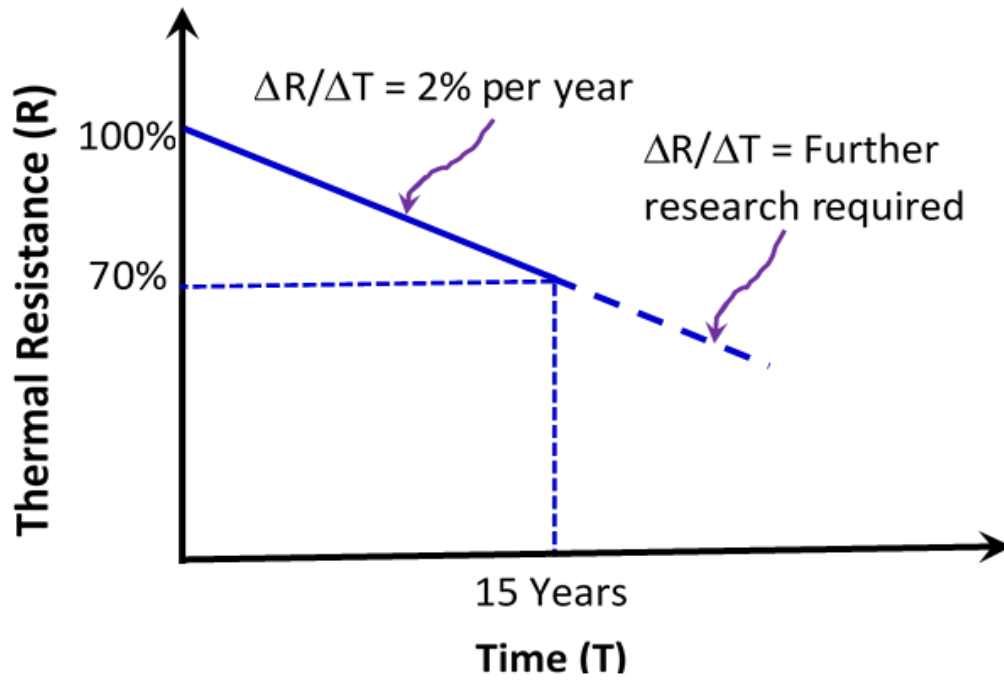


Figure 54: Prediction of long-term performance of VIPs.

## 5 Products and Components

The focus of this Annex is on the long-term performance of super insulation materials (SIMs) used in building products, components and assemblies. In order to ensure the performance of the SIM, they need to be tested under reliable and relevant climate loads. Furthermore, short-term performance of the super insulation material should be guaranteed also. Here short-term performance refers to time between delivering the SIM to construction site until time that the SIM is mounted in a building component e.g. flooring, wall and ceiling. The parameters that can affect the short-term performance of a SIM are for instance storage, rain/snow when the SIM is not protected at the construction site and mechanical damages such as nails and wearing.

SIMs are produced in different part of the world e.g. Europe (Belgium, France, Germany and Great Britain), Asia (China, Korea and Japan) and North America. It is already possible to use SIMs as any other conventional insulation material. Thus, it is very difficult to cover all the existing products, components and assemblies from different producers in this report. However, several case studies, evaluated by experts, are presented in paragraph 5.4.

The aim of this chapter is to present examples of some of the available/commercial building products, components and assemblies, utilizing SIMs, introduced to market by companies. The intention is not to give a full overview of the market as this change rapidly. A readily designed building assembly with all involved products, components and installation procedures simplifies utilization of the SIMs in construction works.

### 5.1 Building products and components with VIP

A previous study by Binz et al. (2005) reported on experiences of using VIPs, which is one type of the super insulation materials discussed in this report, in different building elements. The conclusion was that VIPs should be well protected from mechanical damages (functional loading, inadvertent loading and subsequent manipulation). Simmler and Brunner (2005) did not recommend using unprotected VIPs on-site installation. Meanwhile the authors attenuated this recommendation. In praxis, it proved to be beneficial that for unprotected VIP, vented ones quit easily can be identified during installation. Furthermore, Johansson (2012) summarized experiences from using VIPs in building elements. If a VIP is damaged in the construction, the heat flow through the construction will increase. This has to be considered in the design process. Thus his conclusion was, that if it has an unacceptable consequence for the energy use for heating of the building, the construction should be prepared for easy exchange of the damaged panel. In that case the assembly should be flexible and designed in a way that the VIP is easily accessible and possible to remove. It should also be possible to detect the damaged VIP with e.g. infrared thermography, which means that the VIP should not be covered on both sides with highly conductive materials or be placed behind

a ventilated air space. In Germany, by the national approval, it is required that even in the worst case, that all VIP are no longer evacuated, the construction with VIP has to fulfil the minimum requirements on thermal insulation in order to assure that there is no health risk by possibly growing mould. There is no other constraint on the design of a construction. To fulfil statutory provisions on energy efficiency is up to the planner and the implementing companies. Like for any other building product, the compliance of declared properties is part of the contract between building enterprises and the owner. Failures of the VIP then might be part of a legal dispute.

VIPs must be handled with care and suitable protective measures and tools should be used. A way to avoid unnecessary risks on the construction site is to integrate the VIP in prefabricated elements. There is currently a trend in the building industry where more prefabrication and industrial elements are delivered directly to the construction site. Industrial treatment of the VIP means they will be in a controlled environment where the staff involved in the handling of the panels can gain experience and be trained to treat the VIP with care. Also the surroundings of the site of assembly can be equipped with the right protective equipment such as protective mats and felt shoes (Binz et al., 2005). All attachments and joint details need to be carefully designed since brackets, window attachments and such components may harm the envelope of the VIP. A good design can ensure this which means the designers and builders have to be aware of the special requirements of the VIP early in the design process. If the design and construction are performed following the recommendations from producers, VIP can be feasible and an important mean for building energy efficient buildings (Binz et al., 2005).

The building systems presented in this chapter are partly sent by manufacturer and partly by scanning information available through company webpages.

### SLIM-WALL: SAINT GOBAIN

A sketch of the SLIM-WALL assembly by SAINT GOBAIN is given in Figure 55. The wall has an U-value of between 0.17 W/(m<sup>2</sup>K) and 0.25 W/(m<sup>2</sup>K).

1. Screen printed glass
2. Vacuum insulated panel
3. Warm edge spacer bar
4. Unit seal
5. Fixing
6. Profile
7. Insulating glass unit
8. Coated glass

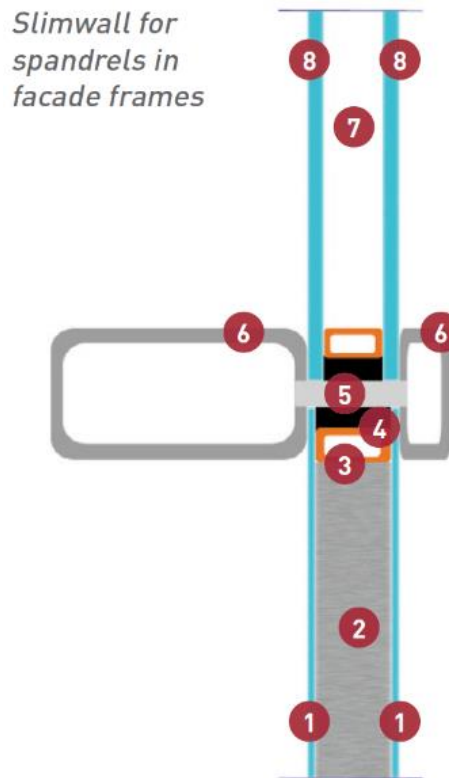


Figure 55: Cross section of the SLIM-WALL.

For more information about the SLIM-WALL refer to (Saint-Gobain, 2017b).

### LOCKPLATE system : WEBER-SAINT GOBAIN

Protected VIP for insulation (see Figure 56). There is no information about the performance of the component. It could depend on the possibility to produce the system with different thicknesses, length and width.

The installation procedures is presented by a video clip (Saint-Gobain, 2017a). A software for planning the needed dimensions of the system in a building is offered by the producer, see Figure 57.

Furthermore, the component is used in a number of buildings, e.g. in Munich, Germany, with a 1300 m<sup>2</sup> surface are insulated by the system (see Figure 58).

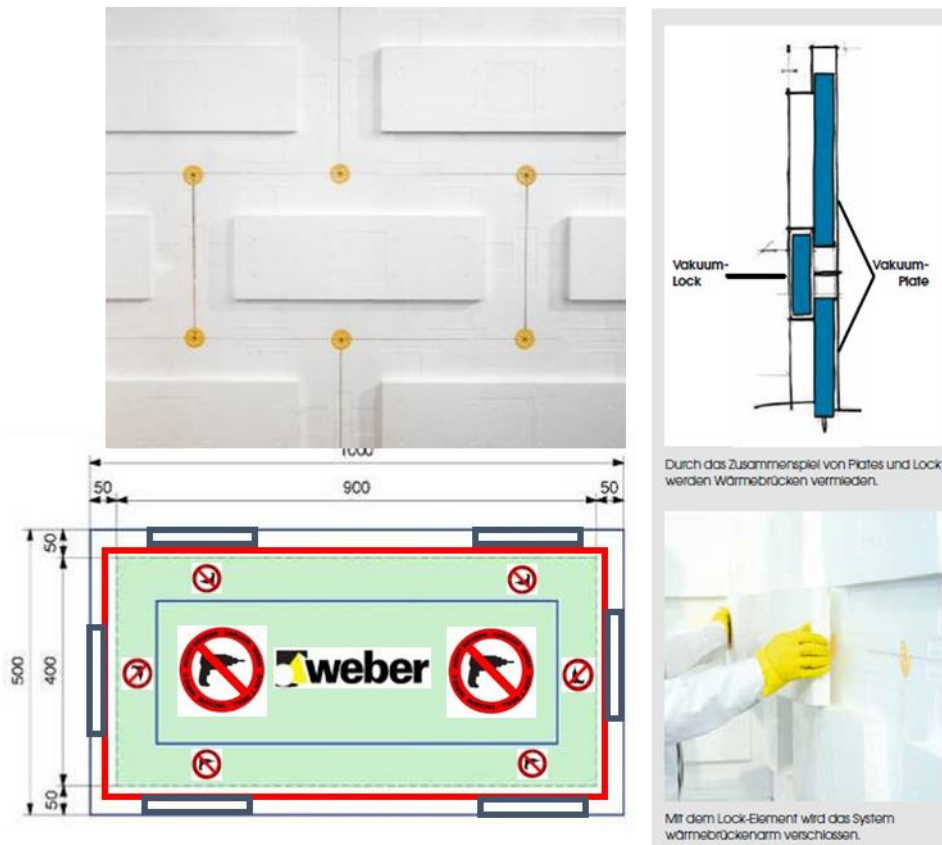


Figure 56: Cross section of the wall, joints and a picture of the component (VIP and protecting layers).

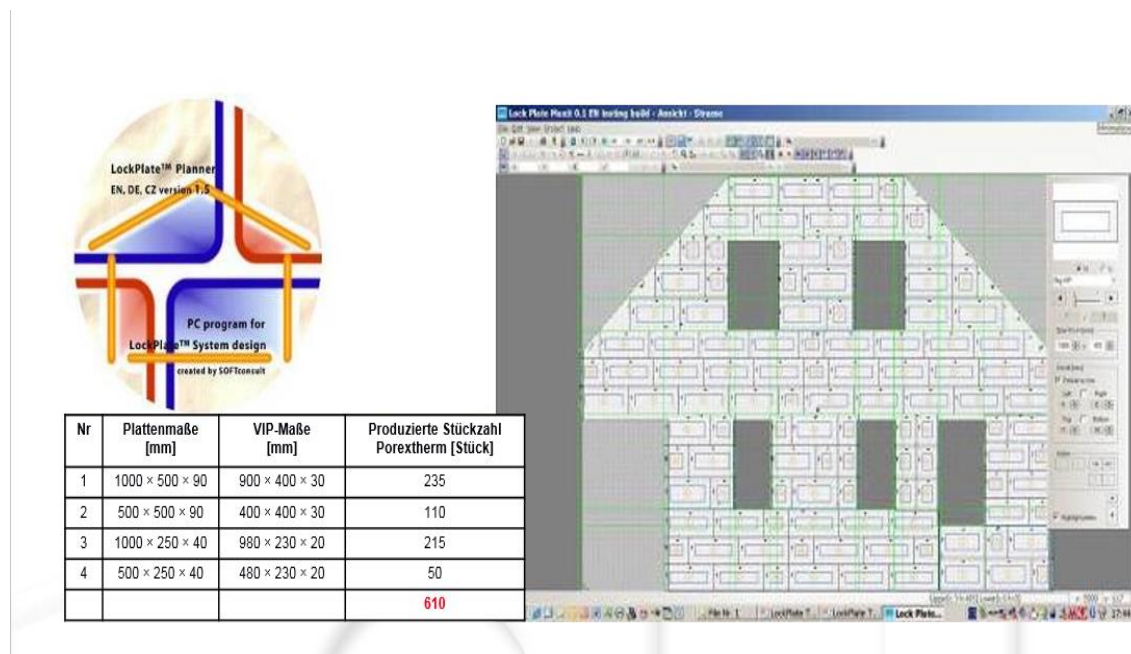


Figure 57: LOCKPLATE Planner software.

## weber.therm LockPlate System – Munich 1300 m<sup>2</sup>



Figure 58: Building in Munich, Germany, where LOCKPLATE system was installed.

### **OPTIM-R External Wall System: Kingspan Insulation**

OPTIM-R External Wall System (see Figure 59) provides solutions for areas that previously had remained non-insulated because of insufficient space available.

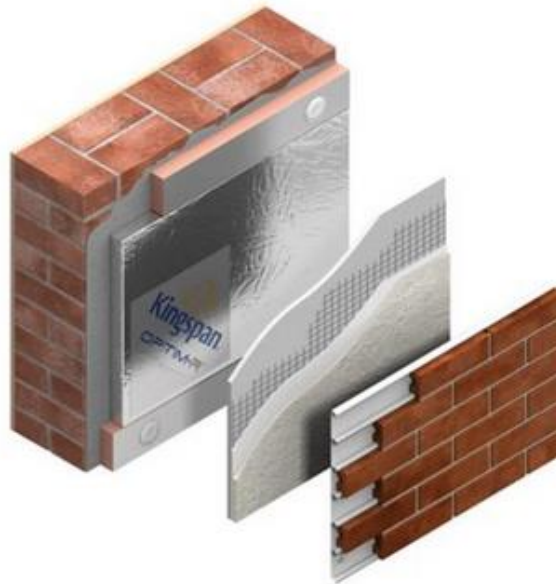


Figure 59: External wall assembly.

For more information, refer to (Kingspan, 2017).



### OPTIMAVIP: ISOVER SAINT-GOBAIN

The first vacuum insulation to receive ACERMI certification. It is offered as a part of a complete regulation-compliant assembly: Optima VIP, see Figure 60. ISOVER has integrated ISOVIP into an optimised assembly (OPTIMA VIP).

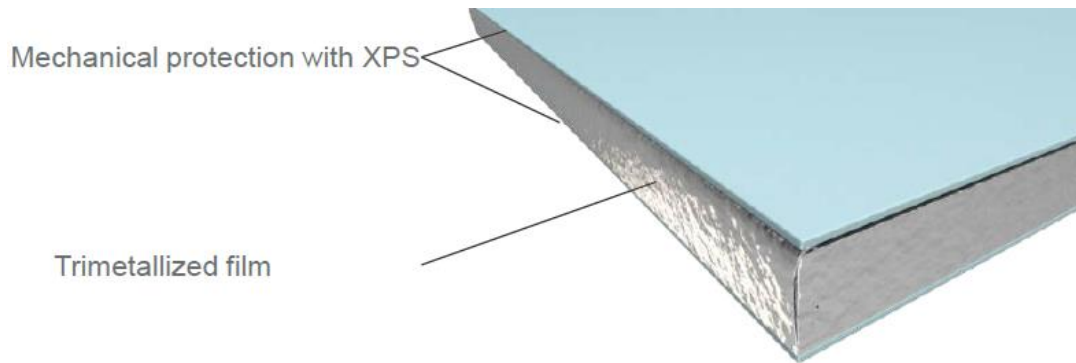


Figure 60: ISOVIP component.

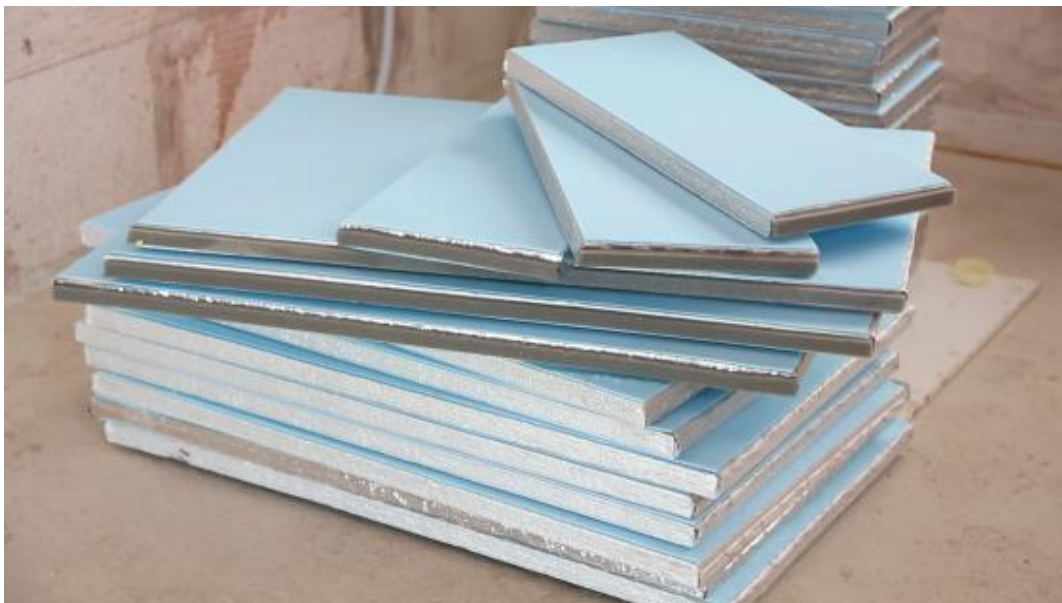


Figure 61 : ISOVIP panels from ISOVER (Saint-Gobain) with the XPS protective layer for secure handling & installation



Figure 62 : OPTIMA-VIP system from ISOVER (Saint-Gobain) installed for internal retrofitting.

For more information refer to (Saint-Gobain, 2016).

<http://www.acermi.com/isolant-certifie/15-018-1072-1/>

[http://www.cstb.fr/pdf/atec/GS20-U/AU150360\\_V1.pdf](http://www.cstb.fr/pdf/atec/GS20-U/AU150360_V1.pdf)

### **Encapsulated VIP: Bauder Ltd.**

BauderVIP is a VIP designed to provide high thermal performance in areas with limited installation height and is ideally suited for terrace and balcony applications. It is encapsulated in polyisocyanurate (PIR), see Figure 63.

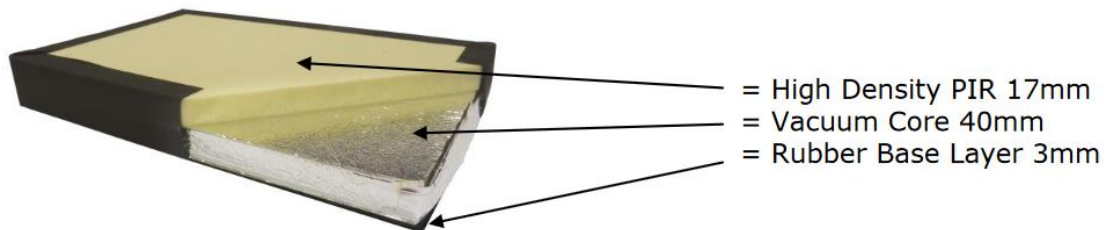


Figure 63: Encapsulated VIP in a flooring component for terrace and balcony.

For more information, refer to (Bauder, 2017).

### Nano flooring insulation: KEVOTHERMAL Ltd.

An encapsulated VIP between two protection layers made of rubber, see Figure 64.

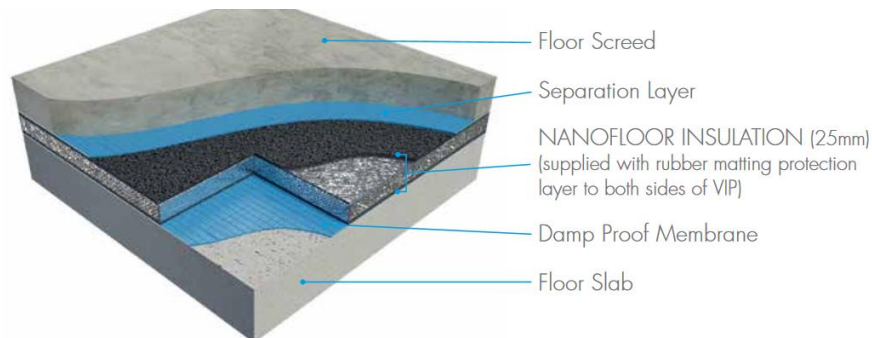


Figure 64: Encapsulated VIP in a flooring component.

For more information, refer to (Kevothermal, 2017).

### Vacupor: Morgan Advanced Materials Porextherm Dämmstoffe GmbH

The Deutsches Institut für Bautechnik (DIBt) in Germany granted the approval for Vacupor® NT-B2-S under the certification number Z-23.11-1662. The approval was granted for various Vacupor® types and its use in a total of ten applications for indoor- and outdoor assemblies. The component is available with polystyrene sheet, extruded polystyrene foam (XPS) and recycling noise-reduction-sheet lining protection (see Figure 65). It is available in seven standard sizes (1200 mm x 1000 mm, 1200 mm x 500 mm, 1000 mm x 600 mm, 1000 mm x 300 mm, 600 mm x 500 mm, 600 mm x 250 mm, 300 mm x 250mm) and in three thicknesses (20 mm, 30 mm and 40 mm).



Figure 65: VIPs available with polystyrene sheet, extruded polystyrene foam (XPS) and recycling noise-reduction-sheet lining protection.

More information is available from (Porextherm, 2017).

### va-Q-vip: va-Q-tec

va-Q-vip is a VIP for construction works. va-Q-vip is covered in a high barrier film and an additional black glass fibre textile, EPS or rubber granulate lamination for mechanical

shock protection (see Figure 66). va-Q-vip is approved for general construction purposes in accordance with approval number Z-23.11-1658 of the "Deutsches Institut für Bautechnik (DIBT)" (va-Q-tec, 2017).



Figure 66: VIP covered by a black glass fibre textile, EPS or rubber granulate lamination.

va-Q-vip elements are unique because of their rectangular edges and corners. This is due to the special edge folding technique "va-Q-seam". Individual elements can be joined together almost seamlessly.

**VIP/QASA: VARIOTEC**

The QASA insulation components are available in 14 approved floor layers and further variants (see Figure 67).



Figure 67: VIP/QASA can be delivered with a number of encapsulation materials.

For more information refer to (VARIOTEC, 2017).

### SLIMISOL – SINIAT (Belgium - France)



Figure 68 : Installation of the SLIMISOL system

For more information refer to [www.slimisol.fr](http://www.slimisol.fr)

### iQ-Panel (NL)

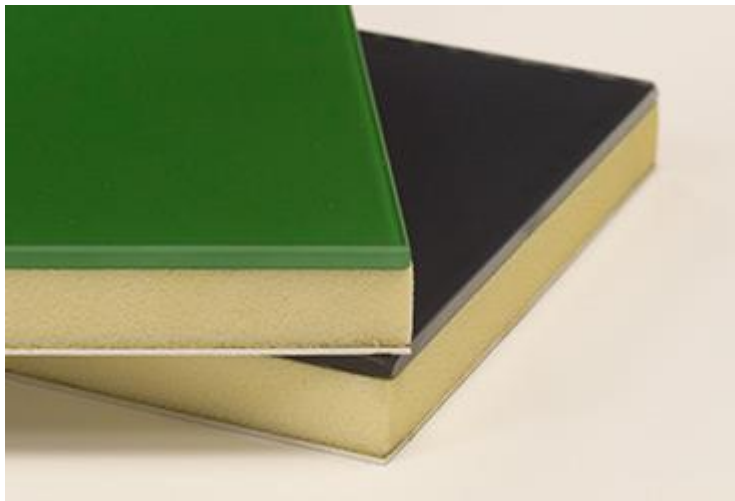


Figure 69 : iQ-prof panel

For more information refer to [www.igpanel.nl/iq-prof/](http://www.igpanel.nl/iq-prof/) and <https://vipa-international.org/uploads/kcFinder/files/Ben%20Arts%20-%20iQ%20Panel.pdf>

### Deck-VQ® - RECTICEL (Belgium)



Figure 70 : Deck-VQ for flat roofs and terraces.

Deck-VQ is a Vacuum Insulation Panel 'VIP' with a robust PIR case designed for flat roofs and terraces.

<https://www.youtube.com/watch?v=UFG7JglcXU8>

<https://www.youtube.com/watch?v=jJuN37rXCwg>

## 5.2 Building products and components with APM

The building components presented in this chapter are partly sent by manufacturer and partly by scanning information available through company webpages.

### **AEROPAN FAST: AEROPAN**

AEROPAN FAST is an insulating panel prefinished for thermal insulation of walls (external and / or internal) and ceilings see Figure 71. It is composed of an insulating Aerogel coupled to a breathable membrane with glass fibre reinforced polypropylene. The AEROPAN FAST panel comes ready with fiberglass mesh embedded and side overlaps, in addition to the predispositions for the dowels. The panel is also already equipped with the predisposition for grouting between the various panels. Panels are delivered with dimensions 1400 mm × 720 mm, for a nominal thickness of 10 mm (or panels having a thickness of 20 mm, 30 mm, 40 mm) with a volumetric density of 230 kg/m<sup>3</sup> (AEROPAN, 2017).

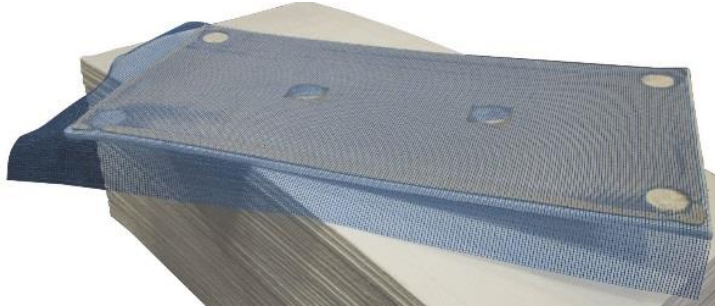


Figure 71: AEROPAN FAST.

**AEROROCK: ROCKWOOL**

Combination of stone wool and aerogel (Rockwool, 2011).

**CALOSTAT: EVONIK**

The wall assembly is 120 mm thick and has a U-value of less than 0.15 W/(m<sup>2</sup> K). The wall is a combination of CALOSTAT and VIP as insulation products, see Figure 72.

For more information about the assembly refer to (Evonik, 2017a) and (Evonik, 2017b).

The system was used in the renovation of an office building for FrymaKoruma in Rheinfelden, Switzerland, see Figure 73.



Figure 72: A wall assembly with CALOSTAT and VIP.





Figure 73: CALOSTAT used in the renovation of an office building in Rheinfelden, Switzerland.

#### **Stadurwall: Stadur-Süd Dämmstoff-Produktions GmbH**

Stadur-Süd has developed an indoor insulation assembly, which is used in energy-efficient building renovation. The thermal insulation assembly combines excellent insulating properties with easy processing in dry construction. Existing heat losses of the building envelope can be reduced by retrofitting the outer wall from the inside. The aerogel technology makes it possible to form insulating materials with ultrafine cell structures, which include air molecules particularly tightly and thus greatly reduce their vibrational behaviour (Stadur-Süd, 2017).

#### **SLENTEX: BASF**

SLENTEX® fits various building assemblies, while fulfilling high energetic requirements. This non-flammable, simple-to-use inorganic aerogel product is the innovation for extremely slim and highly efficient wall insulation (BASF, 2017a).

### **SLENTITE: BASF**

SLENTITE is a polyurethane aerogel. It combines a special chemical formulation with an open porous structure. SLENTITE is an organic aerogel in the form of a mechanically strong panel. This makes it a handsome polyurethane aerogel. With compression resistance of > 300 kPa, it performs twice as well as today's polyurethane insulation panels. The panel can be handled dust free and like conventional construction products (BASF, 2017b).

### **StoTherm In Aevero: Sto**

StoTherm In Aevero is used as an interior insulation assembly. It is a diffusion-free assembly (see Figure 74).

1. Functional layer and bonding: StoLevell In Absolute
2. Insulation: Sto-Aevero interior insulation panel  
Highly effective thermal insulation, based on aerogel technology..
3. Armouring mass: StoLevell In Absolute
4. Reinforcing fabric: Sto fiberglass fabric F
5. Primer: StoPrep Sil
6. Final coating

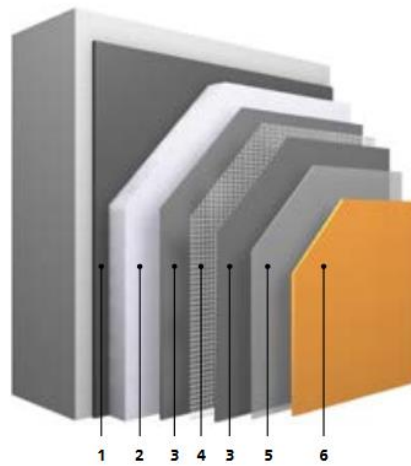
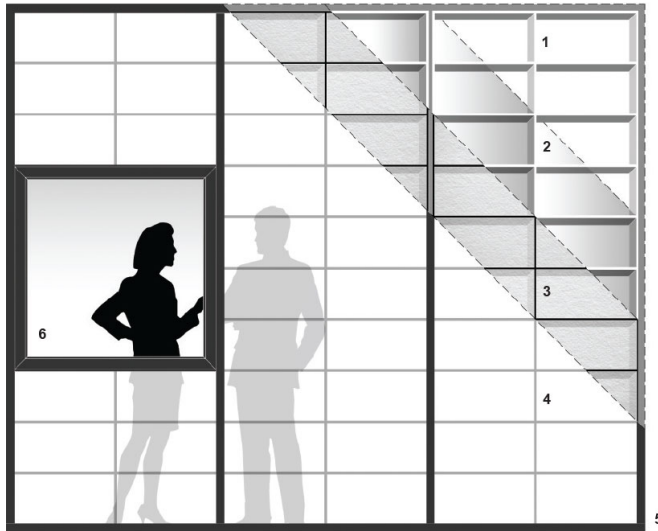


Figure 74: StoTherm In Aevero assembly.

For more information refer to (Sto, 2017).

### **Translucent structural sandwich panel: Kalwall**

In order to transmit visible light, Kalwall has developed translucent thermal insulation options for U-values between 0.53 W/(m<sup>2</sup> K) and 0.05 W/(m<sup>2</sup> K) with a visual light transmittance between 3% and 50% including Cabot's aerogel, see Figure 75.



### Kalwall Cutaway Diagram

- 1) **Aluminum or thermally-broken Grid Core** composed of a series of interlocking I-beams
- 2) Interior shatterproof **Fiber-Reinforced Polymer (FRP) face sheet** formulated to meet finish, flame and smoke requirements of the toughest international codes
- 3) **Translucent Insulation (TI)** options, including Cabot's Lumira™ aerogel offer exceptional thermal up to 0.05 U
- 4) Color stable, exterior **Fiber-Reinforced Polymer FRP face sheet** with a permanent glass veil erosion barrier to eliminate fiberbloom
- 5) **Clamp-tite™ aluminum fastening system**, specifically engineered and available as either standard or thermally-broken with many finish options
- 6) **HC and E-Series fixed and operable windows**, fixed louvers, even opaque panels can all be factory-unitized to add areas of ventilation and vision glazing

Figure 75: Kalwall translucent structural sandwich panel.

For more information refer to (Kalwall, 2017).

### Wall assemblies: Enviroform Solutions

Enviroform Solutions are an approved process partner and distributor of Aspen Aerogel's insulation blanket. Both 5 mm and 10 mm blankets are available in full rolls, part rolls or can be cut to the required quantities or exact dimensions. Aerogel blankets are included in a number of products, components and assemblies where space is at a premium, see example in Figure 76.

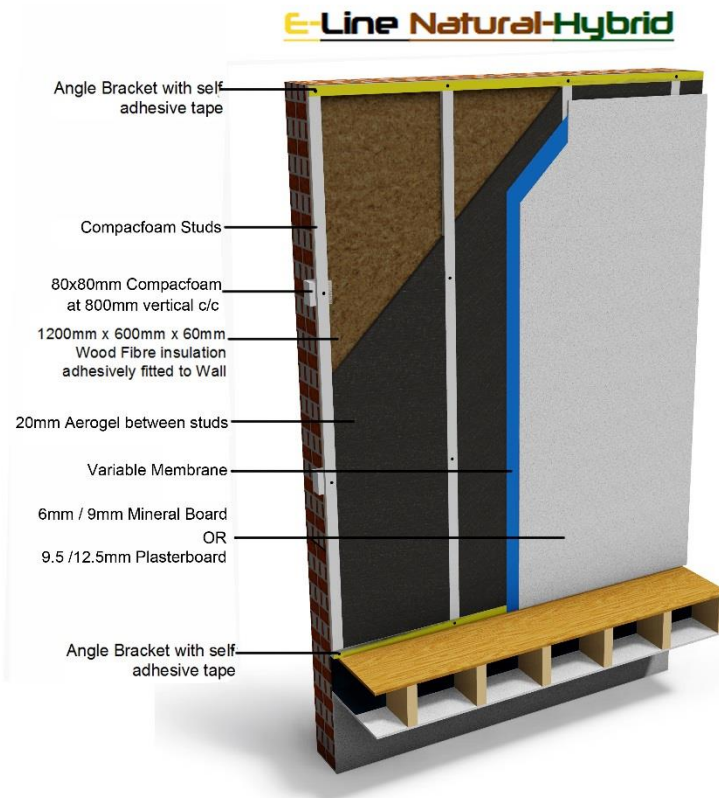


Figure 76: E-Line Natural Hybrid wall assembly.

For more information refer to (enviroform, 2017).

### Window system using aerogel blankets as insert in the frame: Origin

Aerogel can be used in the thermal break of the Origin Window to considerably limit the heat transfer from one environment to another, allowing a U-Value of  $0.9 \text{ W}/(\text{m}^2 \text{ K})$  to be achieved. The Origin Window is fitted as standard with a bespoke thermal break that drastically reduces air flow through the system (Origin, n.d.).

### Windows using aerogel blankets in the frame: ALUPROF

MB-86 is an aluminium window assembly that uses aerogel in the frame. Depending on the required energy saving, there are three optional designs: ST, SI and AERO. The window has high thermal insulating power,  $U_f$ -value from  $0.5 \text{ W}/(\text{m}^2 \text{ K})$ , with the possibility of making large size and heavy weight windows (height up to 2800 mm, width up to 1700 mm, sash weight up to 200 kg) (ALUPROF, 2016).

### High-performance insulating plaster: FIXIT GRUPPE

FIXIT is a high-performance insulating plaster composed of Aerogel granulate as insulating material, lightweight mineral aggregate, natural hydraulic lime, white cement (chromate free) and white calcium hydroxide (see Figure 77).



Figure 77: Application of high-performance insulating plaster on a façade.

For more information, refer to (Fixit, 2017).

### 5.3 Installation guidelines

Guidelines for installation of SIMs can be found in Subtask 3c report of this Annex. It gives an account of transport, handling, installation and quality check of SIMs with the purpose of ensuring material performance and safe handling. The guidelines are based on product specified information from manufacturers as well as scientific publications while relevant regulations are also referred to.

National or European approvals or assessments granted for SIM typically include instructions for installation, use and transport of the products, such as:

*“... Installation details and application details given by the manufacturer xy, which form part of the documentary material for the corresponding ETA and which shall always accompany the kit delivered to the site.*

*The installation shall be carried out in accordance with the instructions from the manufacturer xy. ...”;*

or

*“... Only undamaged/intact insulation boards which have been protected from wetting, weathering, sunlight and mechanical damage of the used multilayer high barrier foil shall be used.*

*When installing the manufacturer's installation instructions shall be followed. The manufacturer's installation instructions have been assessed by the TAB. The insulation board shall only be installed in structures where it is protected from weathering.*

*The product shall not be damaged (e.g. by cutting or drilling) during installation and be protected against damage during the working life by suitable constructional arrangements.*

*The product shall only be installed by competent and/or trained individuals or companies stated in a list of the manufacturer. These companies shall have adequate experience in*

*installing the product. Before installation the thermal insulation boards shall be checked by the installation contractor by means of visual control. The substrate shall be sufficiently flat and clean of construction debris and sharp objects.*

*As to the application of the insulation board and the design values of thermal conductivity/thermal resistance, the respective national regulations shall in addition be observed. ...*

and

*“... In the information accompanying the CE marking the manufacturer shall specify that the product shall be installed following the installation instructions of the manufacturer (only by trained specialized companies) and shall be protected from moisture and mechanical damage during transport, storage and installation. ...*

## 5.4 Case Studies

The aim of this chapter is to present state of the art related to existing projects where SIMs were applied as insulation material. Different assemblies such as external and internal wall insulation, roofs, floors, ceilings are considered. A few case studies from different phases starting from the development and first tests, over demonstration and validation objects, up to bringing it on the market are described. A special issue will be the long-term performance of SIMs in real condition, which is presented more in detail in IEA EBC Annex 65 Subtask 3 report on ‘Practical Applications – Retrofitting at the Building Scale – Field scale’.

Numerous researchers have identified the different applications areas in the USA. In 1999-2002 an investigation commenced by the US Department of Housing and Urban Development evaluated the market potentials for VIP in residential buildings in the US (NAHB Research Center, 2002). 27 different assemblies were evaluated which resulted in ten alternatives of which five were chosen as most promising based on their respective annual market potentials. These were manufactured housing floor panels (45.4 km<sup>2</sup>), exterior doors (9.3 km<sup>2</sup>), garage doors (3.1 km<sup>2</sup>), manufactured housing ceiling panels (45.4 km<sup>2</sup>), and attic access panels/stairway insulation (approx. 1 million access panels).

If it is essential to foster the confidence in the insulation components using SIM, analyses of the performance of commercially realised objects, new buildings as well as refurbishments, after several years of use, might be a good approach. This is done in the German project VIP-PROVE (Heinemann & Kastner, 2010).

The long-term performance of SIMs can be assessed based on available case studies in field and laboratory. Full-scale experiments provide knowledge of practical and technical difficulties as well as data for service life estimation. For certain conclusions to be drawn from the case studies, monitoring is essential. Unfortunately, monitoring is only performed in few case studies. Furthermore, the monitoring time was/is not comparable

to service lifetime of a building e.g. 50 year. In this Annex, Subtask 3 report on “Practical Applications – Retrofitting at the Building Scale – Field scale”, these experiences are gathered and evaluated from a long-term performance perspective.

The IEA Annex 39 investigated the possibilities to use VIP in buildings during 2002-2005 (Binz et al., 2005). In total 20 constructions were analysed in respect of the consequences on energy use, thermal bridges and moisture performance:

- Floor and ceiling insulation (Zug/Switzerland),
- Interior and dormer window insulation (Zürich/Switzerland),
- Terrace insulation (Kerzers/Switzerland),
- Floor insulation in a cold and deep-freeze room (Winterthur/Switzerland),
- Non-load bearing wall sandwich elements (Landschlacht/Switzerland),
- Parapet insulation in window element (Basel/Switzerland),
- Façade insulation with prefabricated panels (Binningen/Switzerland),
- Façade insulation (Nuremberg/Germany),
- Insulation of outside walls, roof and door (Munich/Germany),
- Insulation of the building envelope (Munich/Germany),
- Insulation of a wall heating system (Wernfeld/Germany),
- Jamb-crossbar construction (Erlenbach/Germany),
- Integrated façade element with radiator (Wuerzburg/Germany),
- Insulated prefabricated concrete elements (Ravensburg/Germany),
- Façade insulation (Bersenbrueck/Germany),
- Façade insulation with polystyrene-lined VIP (Trier/Germany),
- Façade insulation (Munich/Germany),
- Floor insulation (Kempten/Germany),
- Floor insulation (Schaffhausen/Switzerland),
- Renovation with insulation under underfloor heating (Gemuenden/Germany).

In the IEA Annex 39 also the influence of temperature and humidity on the ageing of VIP was investigated (Erb et al., 2005), (Simmler et al., 2005).

A first experimental study which compared the expected ageing of VIP based on lab experiments and that found in the real application in a building was undertaken by Schwab et al. (Schwab et al., 2005c; Schwab et al., 2005d).

Unfortunately, few of the case studies mentioned above have long-term monitoring results on neither temperature nor moisture conditions several years after construction.

Heinemann and Kastner (2010), used infrared thermography to investigate buildings with VIPs, where the construction had been finished several years before. 29 predominantly commercially realised buildings with a total area of 8 206 m<sup>2</sup> of installed VIPs were available for the monitoring. Different assemblies with panels of all manufacturers in Germany were considered. From 3 224 m<sup>2</sup> thermo-graphically examined VIP in 19 buildings a total of 12.8% was classified to be conspicuous. Three objects stood out in the investigation with more than 15% of the VIPs damaged. In one of these objects, it

was assumed that errors were made in the design by installing unprotected panels close to an uneven plaster surface. In another building, photos from the construction site showed that the VIPs had been stored and handled improperly by the construction workers. In some of the very first objects, an alkaline glue was used which is not recommended today since it will deteriorate the aluminium in the VIP laminate leading to a reduced service life. In the 16 buildings remaining after the worst objects had been removed, 1 999 m<sup>2</sup> VIPs had been installed. The total percentage damaged VIPs was 4.9% in these objects. The conclusion of the study was that the percentage of damaged panels installed in a construction is low, as long as the recommendations by the producers are followed (Heinemann & Kastner, 2010). Unusual, not expected ageing phenomena or even destroying mechanisms could not be detected, even for the oldest application (> 10 years).

A Norwegian investigation by Grynning et al. (2009) concluded that the building traditions in other parts of the world (Scandinavia, North America, Asia) differ from that in central Europe. Many of the constructions with VIP are located in Switzerland and Germany where the use of timber constructions is less common. For example, Norwegian single-family houses are almost exclusively built using timber frame constructions with a ventilated roof. This means that the conclusions from the Swiss and German studies cannot be applied directly to these Nordic buildings without more evaluations. A number of assemblies where it could be possible to use VIP in the Norway were identified:

- Prefabricated sandwich elements,
- Continuous insulation layer in non-load bearing walls,
- Thin timber frame walls,
- Floors and compact roofs,
- Retrofitting of buildings with limited available space,
- New buildings in areas with high ground costs,
- Doors and windows,
- Insulation of terrace floors where even connections are important.

A number of studies of long-term performance of VIPs were gathered by Johansson (2014). He concluded that in most studies of VIPs available in the literature, it was only the thermal performance of the assembly that was investigated. However, also the moisture performance is important to consider since changes to existing assemblies will influence the risk for moisture damages. The VIP laminate is comparable to a vapour barrier in regards of vapour transfer. This may cause problems around the panels if the connection between them is insufficiently sealed. Moist air could be transported through the layer and into the cold parts of the construction. In some cases, sealing tape has been used to increase the air tightness of the connections. Another option is to use an additional layer of vapour retarder to ensure a vapour tight layer.

One of the 20 constructions studied by Binz et al. (2005) was a listed building in Nuremberg, Germany. The retrofitting was finished in 2000 and Heinemann and Kastner



(2010) investigated the building again in 2001, 2003 and 2008 with infrared thermography. The exterior of one of the gable walls was retrofitted with VIPs as shown in Figure 78. The 15 mm thick VIPs were secured between 35 mm thick horizontal plastic rails that were fastened in an exterior 35 mm thick layer of EPS. The VIPs were attached to the EPS with an adhesive and a vapour barrier was attached between the VIPs and the existing wall. The calculated U-value of the wall was improved from  $0.7 \text{ W}/(\text{m}^2\cdot\text{K})$  to  $0.19 \text{ W}/(\text{m}^2\cdot\text{K})$  which would increase to  $0.32 \text{ W}/(\text{m}^2\cdot\text{K})$  if the panels were damaged. The infrared thermography showed a temperature difference of  $0.7^\circ\text{C}$  between the centre-of-panel and the edge (Binz et al., 2005). As can be seen in Figure 78 one panel underneath the two windows was damaged already in 2001. A second panel had an increased surface temperature in 2008 which indicated that it had been filled with air. However, the remaining VIPs seem to be in good condition after 8 years of operation (Heinemann & Kastner, 2010).

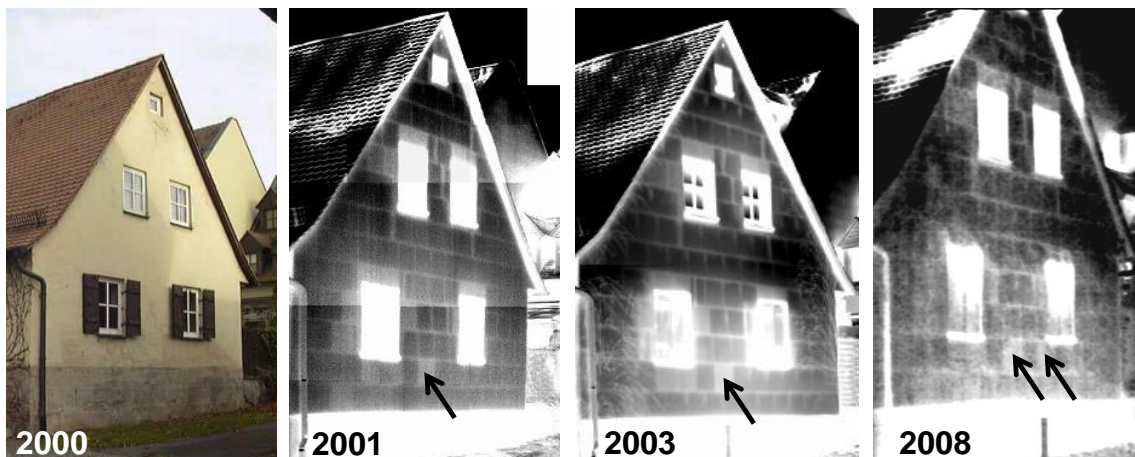


Figure 78: Application of high-performance insulating plaster on a façade. The gable of a listed building was retrofitted on the exterior with 15 mm VIPs using a special plastic rail system. The wall was afterwards investigated using thermography. From left: 2000, 2001, 2003 and 2008 (Photo: ZAE Bayern; (Heinemann & Kastner, 2010)).

Another façade where VIPs had been used was studied by Brunner et al. (2012). A layer of EPS on all sides surrounded the VIPs. Plaster had been applied on the exterior. One day the façade had blisters and cracks in the plaster. When the plaster was removed, 17 out of the 88 VIPs in the façade had been filled with air. The internal pressure in some of the remaining evacuated VIPs was measured and found to be above 200 mbar. Brunner et al. (2012) found that the reason for the failures was that the metallisation process in the production of the metalized multi-layered polymer laminate had failed. The resulting laminate had many defects in the aluminium layers resulting in a large air and moisture permeability. When solar radiation increased the temperature on the surface of the VIPs the internal pressure increased rapidly, and the VIPs were blown up. This problem can be avoided in the future by careful inspection of the laminate before used as VIP envelope.

A Canadian study on long-term performance of VIP in extreme sub-arctic climate in a building retrofit application, glass fibre core VIP sandwiched between two layers of XPS insulation (Figure 79), showed very little ageing (about 5%) over a period of six (6) years (Mukhopadhyaya et al., 2014a).

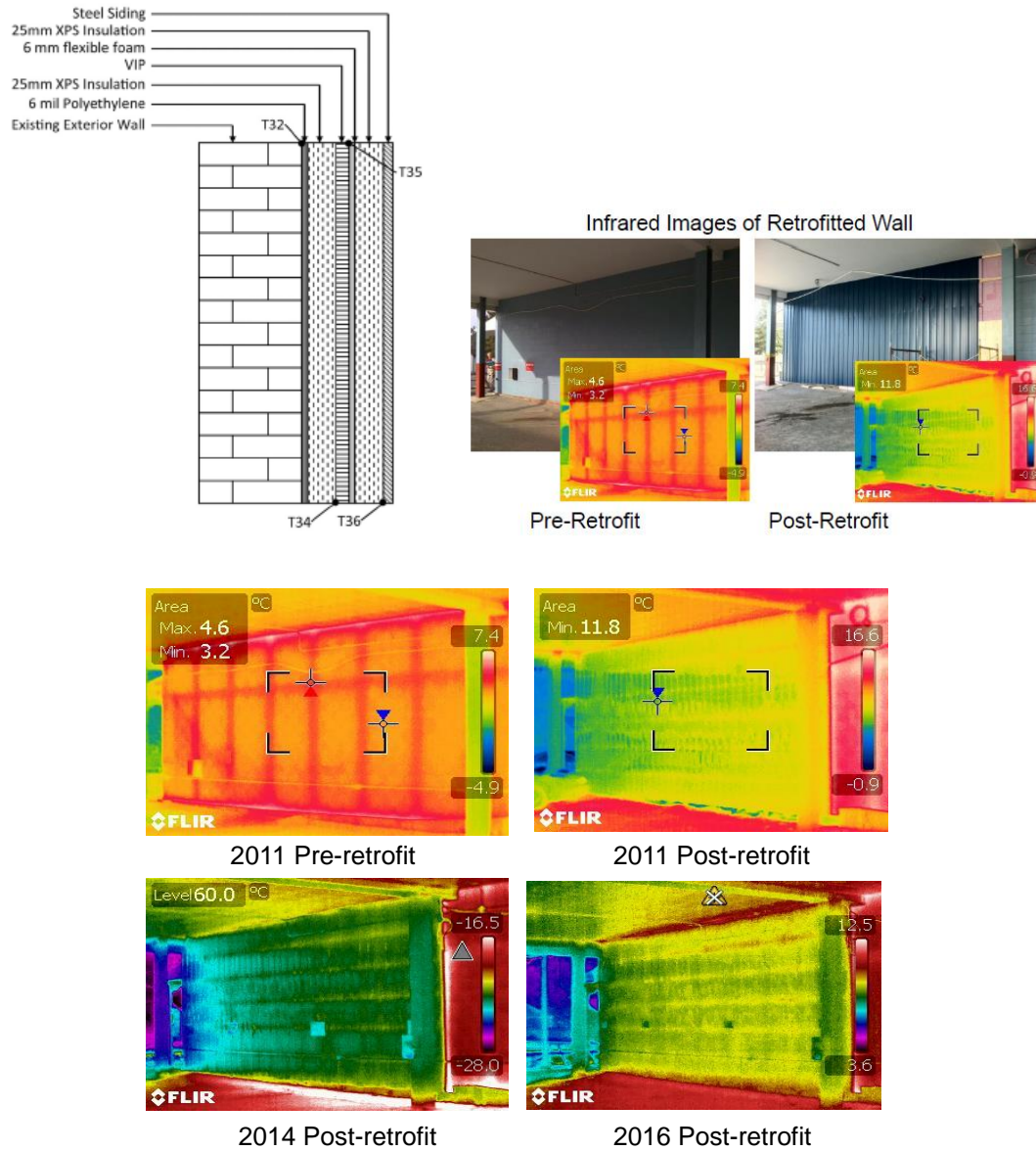


Figure 79: VIP retrofitted exterior wall and infrared images.

More information on case studies with SIMs in building applications can be found in for instance (Binz et al., 2005), (Heinemann & Kastner, 2010), (Johansson, 2012) and from home pages such (ZAE Bayern, 2016) or (ASPEN\_Aerogels, 2016).

## 6 Life Cycle Assessment

The subtask investigated the existing studies on Life Cycle Assessment (LCA) on SIM, according to the product categorisation agreed upon the annex.

LCA is an ISO certified assessment framework that quantifies the environmental impact of products or services over its life cycle. According to ISO14040, LCA is a method to better understand the possible associated impact with products over its life cycle that can assist identifying opportunities to improve the environmental performance of the products or informing decision makers.

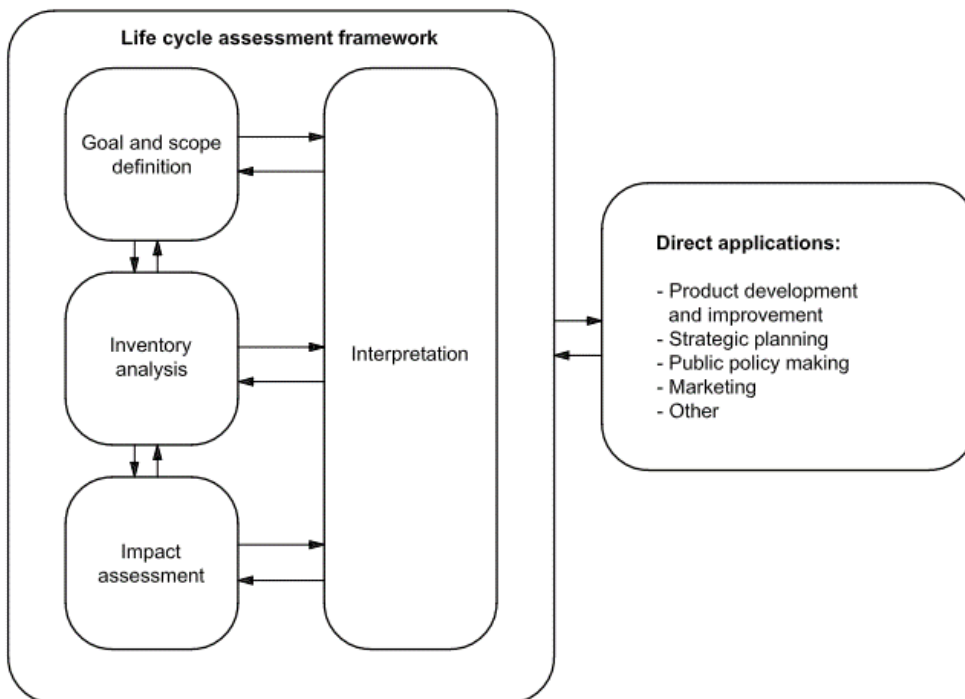


Figure 80: Illustration of stages of LCA according to ISO 14040 (International-Organization-for-Standardization-(ISO), 2006).

As illustrated in Figure 80, the LCA study consists of four phases that are 1) the goal and scope definition, 2) the inventory analysis, 3) the impact assessment and 4) the interpretation. For the impact assessment phase in LCA, there are three Area of Protection, which are 1) human health, 2) natural environment and 3) natural resource (Hauschild et al., 2011). Depending on the goal and scope of the study, the relevant Area of Protection may change which affects the choice of impact assessment method. Therefore, this first phase of LCA is a crucial step, which defines what and how to compare and which types of impact to consider.

For construction products, a European Standard provides a calculation rule for the assessment of the environmental performance on a product level. EN 15804 is such a standard that harmonises the rule for Environmental Product Declarations (EPD) of construction products and services, which plays a vital role to carry out the assessment

on building scale. One of the defined contents in EN 15804 are the life cycle stage module, given in Table 9. The system boundary that covers A1-A3 is typically called “Cradle-to-Factory gate”, while the one covering A1-C4 is referred as “Cradle-to-Grave”. The one that includes D module is called as “Cradle-to-Cradle”.

Table 9: Life cycle stage module of buildings according to EN 15804.

Life cycle stage modules		Name of the sub-module	
Building life cycle information	PRODUCT stage	A1	Raw material supply
		A2	Transport
		A3	Manufacturing
	CONSTRUCTION PROCESS stage	A4	Transport
		A5	Construction, installation processes
	USE stage	B1	Use
		B2	Maintenance
		B3	Repair
		B4	Replacement
		B5	Refurbishment
		B6	Operational energy use
		B7	Operational water use
	END OF LIFE stage	C1	De-construction, demolition
		C2	Transport
C3		Waste processing	
C4		Disposal	
Suppl. information beyond the life cycle	Benefits and loads beyond the system boundary	D	Reuse-, recovery- and/or, recycling potentials- potential

## 6.1 Existing studies of LCA on SIMs

There are several LCA studies made on SIMs. This includes scientific reports, journal papers and EPD. In Table 10, the summary of existing studies on SIMs is shown.

Table 10: Summary of LCA studies on SIMs.

SIM	Institution	Title of project / product name	year	document type	Building life cycle information																		
					Product stage			Construction stage					Use stage					End-of-life stage					
					A1	A2	A3	A4	A5	B1	B2	B3	B4	B5	B6	B7	C1	C2	C3	C4	D		
VIP	CSTB	Clear-up	2012	LCA study	0	0	0	-	-	-	-	-	-	-	-	-	-	-	-	-	-	-	
VIP	Morgan Advanced Materials, Porotherm Dämmstoffe	Vacupor NT-B2-S	2014	EPD	0	0	0	-	-	-	-	-	-	-	-	-	-	-	-	-	-	0	
VIP	Fraunhofer etc.	Development of Super Vacuum Insulating Panels and Product Integration Services	2004	LCA study	0	0	0	-	-	-	-	-	-	-	-	-	-	-	-	-	-	0	
VIP	Microtherm	SlimVac	2013	EPD	0	0	0	-	-	-	-	-	-	-	-	-	-	-	-	-	-	-	
VIP	DOW Corning	Vacuum Insulation Panel	2013	EPD	0	0	0	-	-	-	-	-	-	-	-	-	-	-	-	-	-	0	
VIP	D'Appolonia	FC-DISTRIC	2012	LCA study	0	0	0	-	-	-	-	-	-	-	-	-	-	-	-	-	-	0	
VIP	KTH	A comparative study of the environmental impact of Swedish residential buildings with vacuum insulation panels																					
aerogel	Aspen Aerogels	Spaceloft grey/white	2015	LCA study	0	0	0	-	-	-	-	-	-	-	-	-	-	-	-	-	-	0	
aerogel	Aspen Aerogels	Spaceloft A2	2013	EPD	0	0	0	0	-	-	-	-	-	-	-	-	-	-	-	-	-	-	
aerogel	Brunel University	Novel Retrofit Technologies Incorporating Silica Aerogel for Lower Energy Buildings	2012	LCA study	0	0	0	-	-	-	-	-	-	-	-	-	-	-	-	-	-	-	
aerogel	Fixit	Fixit 222 Aerogel High performance insulating render	2015	EPD	0	0	0	-	-	-	-	-	-	-	-	-	-	-	-	-	-	-	
aerogel	VTT	Aerocoin	2014	LCA study	0	0	0	-	-	-	-	-	-	-	-	-	-	-	-	-	-	-	
aerogel	SINTEF	The Influence of Different Electricity-to-Emissions Conversion Factors on the Choice of Insulation Materials	2014	LCA study	0	0	0	-	-	-	-	-	-	-	-	-	-	-	-	-	-	-	
aerogel	BFE	QualiBOB	2016	LCA study	0	0	0	-	-	-	-	-	-	-	-	-	-	-	-	-	-	0	

There are 14 LCA studies on SIM as of February 2016, where the number of studies was slightly higher for VIP. The noticeable difference among the LCA studies on SIMs is the applied system boundary. For VIP, there are equal numbers of studies that covered the C modules and only the A modules. Whereas for APMs, only one of the studies covered C modules.

## 6.2 International projects on LCA of SIMs

### 6.2.1 VIP

The studies on VIP, which include LCA dates back to early 2000s, which was funded by the European Community. Other international studies that LCA of VIP was part of the project were made after 2010, one investigating the reduction of energy consumption in existing buildings (Clear-up) and another looking at state-of-the-art and innovative technology for district heating pipes (FC-District). One of the studies was further utilised to publish EPD of the panel.

### 6.2.2 APM

The LCA studies on APM were found only on aerogel. One of the studies was a European Commission funded project, which finished at 2015. This project was one of the reference of a project in Switzerland (QualiBOB) that included aerogel, which was published on 2016 (Kasser et al., 2016).

## 6.3 EPD of SIMs

### 6.3.1 VIP

Since several VIP products are out in the market as construction materials, there are a few EPDs publicly available. As of February 2016, there were 3 EPDs of VIP from 3 different manufacturers, which was declared for Belgium, the US and Germany. The 3 declarations were published in 2013 and 2014 where 2 of the declarations included C modules based on Life Cycle Module from EN 15804.

### 6.3.2 APM

For APM, 3 EPDs from 2 aerogel manufacturers were published as of February 2016. The declaration was released on 2013 and 2015 in the US and Switzerland. The declaration from the US covered A1-A4 modules while the one from Switzerland covered A1-A3.

## 6.4 LCA on SIM applications

### 6.4.1 VIP

Among the collected studies, there were two scientific articles that made an LCA of VIP application in buildings. One study was from Norway (Lolli & Hestnes, 2014) on retrofitting the residential building which looked into the carbon emissions of the building with different scenarios of electricity grid mix, as well as the energy demands that depended on the retrofit option. The retrofit option for insulation materials includes aerogel, VIP and rockwool. Another study from Sweden (Karami et al., 2015) conducted LCA of residential buildings with broader scope of environmental impact. The study looked into the application of VIP to residential buildings that was compared traditional insulation material, including mineral wool and EPS.

The conclusion from the both studies were that the life cycle carbon emission of the building using the VIP did not outperform the building with conventional insulation material, when thermal performance of the materials were aligned. Both of the studies looked into A to C modules for carbon emission, which takes operational phase into account.

### 6.4.2 APM

The study above in Norway (Lolli & Hestnes, 2014) includes aerogel as an option for the retrofitting, where the results were the same with VIP. Another study from the UK investigated the CO<sub>2</sub> saving potential of retrofitting options with aerogel over the lifetime of a case building (Dowson, 2012). This study looked into several options for aerogel applications in different building components in order to reach the intended energy performance.

## 6.5 Summary of the state-of-the-art of LCA of SIMs

From the collected information on LCA on SIM, Figure 81 illustrates the greenhouse gas (GHG) emission of various types of insulation materials for A1-A3 modules, where the functional unit was defined as 1 m<sup>2</sup> of wall area of insulation with identical thermal resistance (1 m<sup>2</sup>K/W). The data for conventional insulation materials were adopted from (Kono et al., 2016).

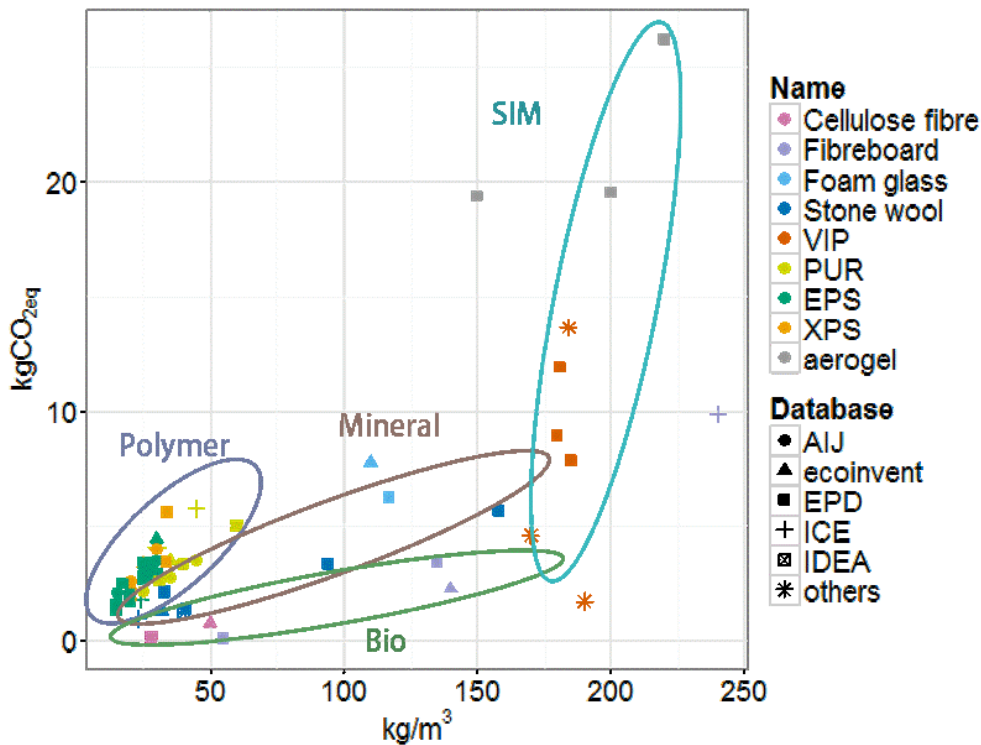


Figure 81: The mapping of carbon emission from various insulation materials with aligned thermal performance (n=57)

From the collected information, the competitiveness of VIP was higher than that of aerogel in terms of cradle-to-gate carbon emission. However, due to the lack of data for LCA on SIM in general, the potential for better representation of the environmental performance of the SIM can be expected. The subtask expects to contribute for the appropriate representation of the SIM as an outcome of the Annex 65.

## 6.6 Embodied energy

Embodied Energy (EE) ([www.annex57.org](http://www.annex57.org)) is a common measure that quantifies the required energy to produce a certain product. The EE typically includes the energy consumed from extraction of the raw materials to the manufacturing of a product (Cradle-to-Factory gate), or to the end of life (Cradle-to-Grave). Today, EE is one of the most commonly applied on LCA studies, which is also adopted by EPD in EN 15804. Despite its frequent use of the method, there seems to be no harmonised approach now.

## 6.7 Life cycle cost calculation

Life Cycle Costing (LCC) is a tool that adheres to life cycle thinking for quantifying the cost of a product or service. The method intends to support decision making beyond the



information of costs of initial investment and to take costs associated to the operational phase and beyond. The result of LCC may differ depending on the time frame of the study. In the context of construction, ISO 15686 standardised the method for construction procurement.

Regarding SIM, the study from Dowson (2012) contains a section assessing the cost effectiveness per ton CO<sub>2</sub> saved over the lifetime of different measures to reduce the carbon emission of the investigated building, which includes aerogel options. The option of ground floor insulation seems to be rather a cost-effective option in the study.

## 7 Conclusion

Following years of research and development, Super-Insulated Materials (SIM) have achieved maturity. Indeed, the SIM that have been developed at present are high performance thermal insulating materials with low (between 5 to 15  $\text{mW}\cdot\text{m}^{-1}\cdot\text{K}^{-1}$ ) thermal conductivity ( $\lambda$ ), and are nowadays considered to have achieved maturity with two main types of materials available on the market. The industry is now rolling out market-ready solutions. VIP (Vacuum Insulation Panels) and APM (Advanced Porous Materials such as aerogel and silica-based materials), are produced by several industrial actors around the world. The largest application sector of VIP remains home appliances, while aerogel is commonly used in the oil and gas industry.

The application of SIM in the building sector is spreading quickly around the world, but in absolute terms the market is growing slowly. SIM's are primarily used for retrofitting and tackling thermal bridges, but more recently they are also being used in China as the burning requirement for building materials has been reinforced after three major high-rise building structures were destroyed by fire, between 2009 and 2011.

Indeed, when using traditional insulation, one must increase the material thickness to reach a low U-value. But thick walls mean either a reduction of the living space, or an increase of the building's footprint (surface & carbon emissions), both aspects forming important concerns for deep energy refurbishment, especially in cities where space (indoor & outdoor) is limited and expensive. Another important point is that large thicknesses of flammable insulating materials drastically increase the fire risk.

Keeping the insulating layer as thin as possible is challenging when one is also trying to keep a high thermal resistance of the wall; this is exactly where SIM come in.

Nevertheless, SIM's remain difficult to handle and to install on-site. For a wider implementation in the building sector, the industry must develop new system solutions adapted to its needs, for example by integrating not only SIM but also fillers, fixings, finishing, frame and thermal breakers. Inspiration could be taken from the domain of window systems, which have evolved from a fragmented domain (separate frames, glazing elements, joints, etc.) to ready-to-install system solutions. This could be especially relevant for Vacuum Insulated Panels, which have some characteristics like double-glazing (no drilling, no cutting, prefabrication, etc.). Some system solutions have been developed during recent years and are now entering the market.

In parallel with industrial development, technical assessment bodies are delivering various certificates for SIM; ACERMI in France, RAL in Germany, LABC in UK, EOTA in Europe. Moreover, standardization is now in progress and VIP standard (CEN/ISO) should be published very soon.

## References

- Aegerter, M., Leventis, N., & Koebel, M. (2011). *Aerogels Handbook* (M. Aegerter, N. Leventis, & M. Koebel Eds. 1 ed. Vol. 8776). New York: Springer-Verlag.
- AEROPAN. (2017). Il sistema prefinito in Aerogel per cappotti termoisolanti. (The pre-finished system Aerogel for thermal insulating coats) [In Italian]. Retrieved from <http://www.aeropan.it/prodotti/aeropan-fast-new/>
- Alam, M., Singh, H., Brunner, S., & Naziris, C. (2014). Experimental characterisation and evaluation of the thermo-physical properties of expanded perlite-Fumed silica composite for effective vacuum insulation panel (VIP) core. *Energy and Buildings*, 69, 442-450.
- Alam, M., Singh, H., & Limbachiya, M. C. (2011). Vacuum Insulation Panels (VIPs) for building construction industry - A review of the contemporary developments and future directions. *Applied Energy*, 88(11), 3592-3602. doi:10.1016/j.apenergy.2011.04.040
- Alam, M., Singh, H., Suresh, S., & Redpath, D. A. G. (2017). Energy and economic analysis of Vacuum Insulation Panels (VIPs) used in non-domestic buildings. *Applied Energy*, 188, 1-8. doi:<http://dx.doi.org/10.1016/j.apenergy.2016.11.115>
- ALUPROF. (2016). ALUPROF SYSTEMS OVERVIEW. Retrieved from [http://www.aluprof.co.uk/uploads/files/Aluprof%20Systems%20Overview\\_09.2016.pdf](http://www.aluprof.co.uk/uploads/files/Aluprof%20Systems%20Overview_09.2016.pdf)
- Annex 24. (1995). EBC Annex 24 Heat, Air and Moisture Transport. Retrieved from <http://www.iea-ebc.org/projects/completed-projects/ebc-annex-24/>
- Annex 41. (2007). EBC Annex 41 Whole Building Heat, Air and Moisture Response (MOIST-EN). Retrieved from <http://www.iea-ebc.org/projects/completed-projects/ebc-annex-41/>
- Annex 52. (2014). EBC Annex 52 Towards Net Zero Energy Solar Buildings, a joint project with IEA Solar Heating and Cooling (Task 40). Retrieved from <http://www.iea-ebc.org/projects/completed-projects/ebc-annex-52/> and <http://task40.iea-shc.org/about>
- Annex 57. (2016). EBC Annex 57 Evaluation of Embodied Energy & Carbon Dioxide Emissions for Building Construction. Retrieved from <http://www.iea-ebc.org/projects/ongoing-projects/ebc-annex-57/>
- Annex 58. (2016). EBC Annex 58 Reliable Building Energy Performance Characterisation Based on Full Scale Dynamic Measurements. Retrieved from <http://www.iea-ebc.org/projects/completed-projects/ebc-annex-58/>; <http://www.kuleuven.be/bwf/projects/annex58/index.htm>
- Annex 61. (2016). EBC Annex 61 Business and Technical Concepts for Deep Energy Retrofit of Public Buildings. Retrieved from <http://www.iea-ebc.org/projects/ongoing-projects/ebc-annex-61/>
- Araki, K., Kamoto, D., & Matsuoka, S.-i. (2009). Optimization about multilayer laminated film and getter device materials of vacuum insulation panel for using at high temperature. *Journal of Materials Processing Technology*, 209(1), 271-282. doi:<http://dx.doi.org/10.1016/j.jmatprotec.2008.01.054>
- ASPEN. (2014). *Spaceloft Technical Guidance Document* Retrieved from <http://www.aerogel.uk.com/spaceloft-tech-guide.pdf>

- ASPEN\_Aerogels. (2016). ASPEN Aerogels. Retrieved from <http://www.aerogel.com/resources/case-studies/>
- ASTM C1303 / C1303M-15. (2015). Standard Test Method for Predicting Long-Term Thermal Resistance of Closed-Cell Foam Insulation. ASTM International, West Conshohocken, PA, [www.astm.org](http://www.astm.org).
- ASTM C1484 - 10. (2010). Standard Specification for Vacuum Insulation Panels. ASTM International, West Conshohocken, PA, [www.astm.org](http://www.astm.org).
- ASTM C1728 – 12. (2012). Standard Specification for Flexible Aerogel Insulation. ASTM International, West Conshohocken, PA, [www.astm.org](http://www.astm.org).
- Baetens, R., Jelle, B. P., & Gustavsen, A. (2011). Aerogel insulation for building applications: A state-of-the-art review. *Energy and Buildings*, 43(4), 761-769.
- Baetens, R., Jelle, B. P., Thue, J. V., Tenpierik, M. J., Grynning, S., Uvslokk, S., & Gustavsen, A. (2010). Vacuum insulation panels for building applications: A review and beyond. *Energy and Buildings*, 42(2), 147-172. doi:10.1016/j.enbuild.2009.09.005
- BASF. (2017a). SLENTEX® The Flexible Thermal Insulation Solution. Retrieved from <http://www.polyurethanes.basf.com/pu/solutions/en/content/group/innovation/products/SLENTEX>
- BASF. (2017b). SLENTITE® High-performance insulating material. Retrieved from <http://www.polyurethanes.basf.com/pu/solutions/en/content/group/innovation/products/slentite/intro>
- Bauder. (2017). Encapsulated VIP. Retrieved from <http://www.bauder.co.uk/assets/b/a/audervip-insulation.pdf>
- Beck, A., & Binder, M. (2008). Heat and Moisture Transport in Vacuum Insulation Panels. *Bauphysik*, 30(6), 463-468. doi:10.1002/bapi.200810061
- Biedermann, A., Kudoke, C., Merten, A., Minogue, E., Rotermund, U., Ebert, H. P., Heinemann, U., Fricke, J., & Seifert, H. (2001a). Analysis of heat transfer mechanisms in polyurethane rigid foam. *Journal of Cellular Plastics*, 37(6), 467-483.
- Biedermann, A., Kudoke, C., Merten, A., Minogue, E., Rotermund, U., Seifert, H., Ebert, H. P., Heinemann, U., & Fricke, J. (2001b). Heat-transfer mechanisms in polyurethane rigid foam. *High Temperatures - High Pressures*, 33(6), 699-706.
- Binz, A., Moosmann, A., Steinke, G., Schonhardt, U., Fregnan, F., Simmler, H., Brunner, S., Wakili, K. G., Bundi, R., Heinemann, U., Schwab, H., Cauberg, H., Tenpierik, M., Johannesson, G., Torsell, T., Erb, M., & Nussbaumer, B. (2005). *Vacuum Insulation in the Building Sector - Systems and Applications (Subtask B)*. Retrieved from [http://www.iea-ebc.org/Data/publications/EBC\\_Annex\\_39\\_Report\\_Subtask-B.pdf](http://www.iea-ebc.org/Data/publications/EBC_Annex_39_Report_Subtask-B.pdf)
- Boafo, F. E., Chen, Z. F., Wu, W. P., Chen, Q., Li, B. B., & Zhou, J. M. (2012). Ultrafine glass fiber vacuum insulation panel for building insulation *Advances in Civil Engineering and Building Materials* (pp. 77-81): CRC Press.
- Bouquerel, M. (2012). *Influence des transferts hygro-aérauliques sur les transferts thermiques dans les super-isolants nanostructurés sous vide* (PhD thesis), INSA de Lyon. Retrieved from <http://www.sudoc.abes.fr/DB=2.1/SRCH?IKT=12&TRM=169890325>

- Bouquerel, M., Duforestel, T., Baillis, D., & Rusaouen, G. (2012a). Heat transfer modeling in vacuum insulation panels containing nanoporous silicas—A review. *Energy and Buildings*, 54, 320-336. doi:<http://dx.doi.org/10.1016/j.enbuild.2012.07.034>
- Bouquerel, M., Duforestel, T., Baillis, D., & Rusaouen, G. (2012b). Mass transfer modeling in gas barrier envelopes for vacuum insulation panels: A review. *Energy and Buildings*, 55, 903-920. doi:<http://dx.doi.org/10.1016/j.enbuild.2012.09.004>
- Brunner, S., & Ghazi Wakili, K. (2014). Hints for an additional aging factor regarding the thermal performance of vacuum insulation panels with pyrogenic silica core. *Vacuum*, 100, 4-6. doi:<http://dx.doi.org/10.1016/j.vacuum.2013.07.033>
- Brunner, S., Stahl, T., & Ghazi Wakili, K. (2012). An example of deteriorated vacuum insulation panels in a building facade. *Energy and Buildings*, 54, 278-282.
- Brunner, S., Tharian, P. J., Simmler, H., & Ghazi Wakili, K. (2008). Focused ion beam (FIB) etching to investigate aluminium-coated polymer laminates subjected to heat and moisture loads. *Surface & Coatings Technology*, 202(24), 6054-6063.
- Buratti, C., & Moretti, E. (2012). Glazing systems with silica aerogel for energy savings in buildings. *Applied Energy*, 98, 396-403. doi:10.1016/j.apenergy.2012.03.062
- Buratti, C., Moretti, E., & Belloni, E. (2016a). Aerogel Plasters for Building Energy Efficiency. In F. Pacheco Torgal, C. Buratti, S. Kalaiselvam, C.-G. Granqvist, & V. Ivanov (Eds.), *Nano and Biotech Based Materials for Energy Building Efficiency* (pp. 17-40): Springer International Publishing Switzerland.
- Buratti, C., Moretti, E., & Belloni, E. (2016b). Nanogel Windows for Energy Building Efficiency. In F. Torgal (Ed.), *Nano and Biotech Based Materials for Energy Building Efficiency* (pp. 41-69). Switzerland Springer International
- CAN/ULC S770-15. (2015). Standard Test Method for Determination of Long-term Thermal Resistance of Closed-Cell Thermal Insulating Foams: Underwriters Laboratories of Canada, 02/01/2015
- Caps, R., & Fricke, J. (2000). Thermal Conductivity of Opacified Powder Filler Materials for Vacuum Insulations. *International Journal of Thermophysics*, 21(2), 445-452. doi:10.1023/a:1006691731253
- Caps, R., Heinemann, U., Ehrmantraut, M., & Fricke, J. (2001). Evacuated insulation panels filled with pyrogenic silica powders: properties and applications. *High Temperatures-High Pressures*, 33(2), 151-156. doi:DOI 10.1068/htwu70
- Casini, M. (2016). *Smart Buildings, Advanced Materials and Nanotechnology to improve Energy Efficiency and Environmental Performance*. Duxford, UK: Woodhead publishing.
- Chen, Y., Davalos, J. F., Ray, I., & Kim, H. Y. (2007). Accelerated aging tests for evaluations of durability performance of FRP reinforcing bars for concrete structures. *Composite Structures*, 78(1), 101-111.
- Collins, K. E., Goncalves, M. C., Romero, R. B., Conz, R. F., de Camargo, V. R., & Collins, C. H. (2008). Low temperature ageing of silicas Gasil-I and TK800. *Applied Surface Science*, 254(13), 4029-4035.
- Coquard, R., Baillis, D., Grigorova, V., Enguehard, F., Quenard, D., & Levitz, P. (2013). Modelling of the conductive heat transfer through nano-structured porous silica materials. *Journal of Non-Crystalline Solids*, 363, 103-115. doi:<http://dx.doi.org/10.1016/j.jnoncrysol.2012.11.053>

- CP-DS database. *Legislation on substances in construction products*. Retrieved from <http://ec.europa.eu/growth/tools-databases/cp-ds/>.
- Crank, J., & Park, G. S. (1968). *Diffusion in Polymers* (J. Crank & G. S. Park Eds.). London and New York: Academic Press.
- Cuce, E., Cuce, P. M., Wood, C. J., & Riffat, S. B. (2014). Toward aerogel based thermal superinsulation in buildings: A comprehensive review. *Renewable & Sustainable Energy Reviews*, 34, 273-299. doi:10.1016/j.rser.2014.03.017
- Di, X., Gao, Y., Bao, C., Hu, Y., & Xie, Z. g. (2013). Optimization of glass fiber based core materials for vacuum insulation panels with laminated aluminum foils as envelopes. *Vacuum*, 97, 55-59. doi:<http://dx.doi.org/10.1016/j.vacuum.2013.04.005>
- Dorcheh, A. S., & Abbasi, M. H. (2008). Silica aerogel; synthesis, properties and characterization. *Journal of Materials Processing Technology*, 199(1-3), 10-26. doi:10.1016/j.jmatprotec.2007.10.060
- Dowson, M. (2012). *Novel retrofit technologies incorporating silica aerogel for lower energy buildings*. (Doctoral Thesis), Brunel University School of Engineering and Design. Retrieved from <http://bura.brunel.ac.uk/handle/2438/7075>
- Drouin, M., Mukhopadhyaya, P., & Shirliffe, C. (2012). Insight into LTTR. *Roofing Canada, Spring/Summer 2012*, pp. 10-18.
- Dubelley, F. (2016). *Mécanismes de dégradation des enveloppes barrières pour application panneaux isolants sous vide*. (PhD thesis), University Savoie Mont Blanc. Retrieved from <http://www.theses.fr/2016GREAI007>
- Dubelley, F., Planes, E., Bas, C., Pons, E., Yrieix, B., & Flandin, L. (2017a). Dimensional instabilities of polyester and polyolefin films as origin of delamination in laminated multilayer. *Journal of Polymer Science Part B: Polymer Physics*, 55(4), 309-319. doi:10.1002/polb.24274
- Dubelley, F., Planes, E., Bas, C., Pons, E., Yrieix, B., & Flandin, L. (2017b). The hygrothermal degradation of PET in laminated multilayer. *European Polymer Journal*, 87, 1-13. doi:<http://doi.org/10.1016/j.eurpolymj.2016.12.004>
- Ebert, H. P. (2013). High-Performance Insulation Materials. In F. P. Torgal, M. Mistretta, A. Kaklauskas, C. G. Granqvist, & L. F. Cabeza (Eds.), *Nearly Zero Energy Building Refurbishment: A Multidisciplinary Approach* (Vol. 1, pp. 457-481). London: Springer-Verlag.
- Enkvist, P.-A., Nauc ler, T., & Rosander, J. (2007). A cost curve for greenhouse gas reduction. *McKinsey Quarterly*.
- enviroform. (2017). Spaceloft Aerogel Insulation. Retrieved from <http://enviroform-insulation.com/product/aerogel-sheets/>
- Erb, M., Heinemann, U., Schwab, H., Simmler, H., Brunner, S., Wakili, K. G., Bundi, R., Kumaran, K., Mukhopadhyaya, P., Quenard, D., Sallee, H., Binz, A., Steinke, G., & Moosmann, A. (2005). *Vacuum Insulation - Panel Properties and Building Applications - Summary*. Retrieved from [http://www.iea-ebc.org/Data/publications/EBC\\_Annex\\_39\\_Report\\_Summary\\_Subtask-A-B.pdf](http://www.iea-ebc.org/Data/publications/EBC_Annex_39_Report_Summary_Subtask-A-B.pdf)  
[http://www.ecbcs.org/docs/Annex\\_39\\_Report\\_Summary\\_Subtask-A-B.pdf](http://www.ecbcs.org/docs/Annex_39_Report_Summary_Subtask-A-B.pdf)

- ETA. (2017). European Technical Approvals and European Technical Assessments ETAs. Retrieved from <https://www.eota.eu/en-GB/content/do-you-want-to-ce-mark-your-construction-product/18/>
- ETAG 004. (2011). *Guideline for European technical approval of external thermal insulation composite systems (ETICS) with rendering* Retrieved from <https://www.eota.eu/handlers/download.ashx?filename=endorsed-etags%5cetag004%2fetag-004-february-2013.pdf>.
- EU Directive 67/548/EEC. (1967). *Council Directive 67/548/EEC of 27 June 1967 on the approximation of laws, regulations and administrative provisions relating to the classification, packaging and labelling of dangerous substances*. Retrieved from <http://eur-lex.europa.eu/legal-content/EN/TXT/?uri=celex:31967L0548>.
- EU Directive 2010/31/EU. (2010). Directive 2010/31/EU of the European Parliament and of the Council of 19 May 2010 on the energy performance of buildings. Retrieved from <http://eur-lex.europa.eu/legal-content/EN/TXT/?uri=CELEX:32010L0031>
- EU Regulation (EC) No 1272/2008. (2008). *Regulation (EC) No 1272/2008 of the European Parliament and of the Council of 16 December 2008 on classification, labelling and packaging of substances and mixtures, amending and repealing Directives 67/548/EEC and 1999/45/EC, and amending Regulation (EC) No 1907/2006*. Retrieved from <http://eur-lex.europa.eu/legal-content/EN/TXT/?qid=1486495811310&uri=CELEX:32008R1272>.
- European Commission. (2013). Legislation 89/106/EEC Construction products (expired 01/07/2013) - ETAs without guideline (European Technical Approvals). Retrieved from <http://ec.europa.eu/growth/tools-databases/nando/index.cfm?fuseaction=directive.annex> and more specific <http://ec.europa.eu/growth/tools-databases/nando/index.cfm?fuseaction=cp.etas>
- Evonik. (2017a). Calostat. Retrieved from [http://web.ornl.gov/sci/buildings/2016/docs/presentations/workshops/workshop-4/Workshop4\\_Gartner.pdf](http://web.ornl.gov/sci/buildings/2016/docs/presentations/workshops/workshop-4/Workshop4_Gartner.pdf)
- Evonik. (2017b). Calostat-Insulating Façade Elements. Retrieved from <http://corporate.evonik.com/layouts/Websites/Internet/DownloadCenterFileHandler.ashx?fileid=2392>
- Fixit. (2017). Aerogel Insulating Plaster System. Retrieved from [http://www.fixit.ch/aerogel/pdf/upload/1399972839-Fixit\\_222\\_Aerogel\\_Flyer\\_A6\\_EN.pdf](http://www.fixit.ch/aerogel/pdf/upload/1399972839-Fixit_222_Aerogel_Flyer_A6_EN.pdf)
- Flamant, G., Janssens, A., & Zimmerman, M. (2012). *Superinsulating Materials- Present Applications and Ongoing Research* (G. Flamant, A. Janssens, & M. Zimmerman Eds.). Zelzate, Belgium: University Press.
- Fricke, J. (1993). Materials research for the optimization of thermal insulations. *High Temperatures - High Pressures*, 25(1993), 379-390.
- Fricke, J. (1994). *Thermal Transport in Nanostructured Porous Materials and Their Optimization as Thermal Superinsulators*. Paper presented at the 10th Intl. Heat Transfer Conference, Brighton, England, August 14-18, 1994.
- Fricke, J. (2005). From Dewars to VIPs - One Century of Progress in Vacuum Insulation Technology. *7th International Vacuum Insulations Symposium 2005*, 28-29. Sept. 2005, Duebendorf-Zurich, Switzerland. Retrieved from

[http://web.archive.org/web/20071026091535/http://www.empa-ren.ch/ren/PDF/VIP05/01\\_Fricke.pdf](http://web.archive.org/web/20071026091535/http://www.empa-ren.ch/ren/PDF/VIP05/01_Fricke.pdf)

- Fricke, J., Büttner, D., Caps, R., Gross, J., & Nilsson, O. (1987). *Solid Conductivity of Loaded Fibrous Insulations*. Paper presented at the ASTM Symposium on Insulation Materials, Testing and, Applications Bal Harbour, Fla.
- Fricke, J., & Caps, R. (1988). Heat-Transfer in Thermal Insulations - Recent Progress in Analysis. *International Journal of Thermophysics*, 9(5), 885-895. doi:Doi 10.1007/Bf00503253
- Fricke, J., & Emmerling, A. (1992). Aerogels - Preparation, Properties, Applications. *Structure and Bonding*, 77, 37-87.
- Fricke, J., Heinemann, U., & Ebert, H. P. (2008). Vacuum insulation panels - From research to market. *Vacuum*, 82(7), 680-690.
- Fricke, J., Schwab, H., & Heinemann, U. (2006). Vacuum insulation panels - Exciting thermal properties and most challenging applications. *International Journal of Thermophysics*, 27(4), 1123-1139.
- Garnier, G. (2009). *Conception et optimisation des enveloppes pour super-isolants thermiques sous vide*. (PhD thesis), Institut National Polytechnique de Grenoble, Grenoble. Retrieved from <http://www.theses.fr/2009INPG0007>
- Garnier, G., Marouani, S., Yrieix, B., Pompeo, C., Chauvois, M., Flandin, L., & Brechet, Y. (2011). Interest and durability of multilayers: from model films to complex films. *Polymers for Advanced Technologies*, 22(6), 847-856. doi:10.1002/pat.1587
- Gonçalves, W., Morthomas, J., Chantrenne, P., Perez, M., Foray, G., & Martin, C. L. (2016). Molecular dynamics simulations of amorphous silica surface properties with truncated Coulomb interactions. *Journal of Non-Crystalline Solids*, 447, 1-8. doi:<http://dx.doi.org/10.1016/j.jnoncrysol.2016.05.024>
- Grynning, S., Baetens, R., Jelle, B., Gustavsen, A., Uvsløkk, S., & Meløysund, V. (2009). *Vakuumisolasjonspaneler for bruk i bygninger – Egenskaper, krav og muligheter. Prosjektrapport 31-2009 (Vacuum insulation panels for building applications – Properties, requirements and possibilities)*. [In Norwegian]. Retrieved from Oslo, Norway: <http://www.sintef.no/globalassets/upload/byggforsk/publikasjoner/sb-prrapp-31.pdf>
- Hanika, M. (2004). *Zur Permeation durch aluminiumbedampfte Polypropylen- und Polyethylenterephthalatfolien*. (PhD thesis), Technische Universität München, München, Germany. Retrieved from <https://mediatum.ub.tum.de/doc/601903/601903.pdf>
- Hauschild, M., Goedkoop, M., Guinee, J., Heijungs, R., Huijbregts, M., Jolliet, O., Margni, M., & De Schryver, A. (2011). *Recommendations for Life Cycle Impact Assessment in the European context*. Retrieved from
- Heinemann, U. (2008). Influence of water on the total heat transfer in 'evacuated' insulations. *International Journal of Thermophysics*, 29(2), 735-749.
- Heinemann, U. (2013). *Vacuum Insulation Panels — Potentials, Challenges and Applications*. Paper presented at the 11th International Vacuum Insulation Symposium (IVIS) 2013, Duebendorf-Zurich, Switzerland.
- Heinemann, U., Büttner, D., Stark, C., Kraus, D., Albrecht, W., Ortjohann, J., & Caps, R. (2007). *Vakuumisolationspaneelen für die Anwendung im Bauwesen : VIP-Bau ; Koordinations- und Informationsstelle und Qualitätskontrolle von Vakuumisolationspaneelen ;*



- Schlussbericht. [In German] - VIP-BAU - Vacuum insulation panels in building applications. Coordination and information centre and quality assurance; Final report. (ZAE 2-0707-16-(2007)). Retrieved from Wuerzburg, Germany: <https://www.tib.eu/suchen/id/TIBKAT:566437236/>*
- Heinemann, U., Caps, R., & Fricke, J. (1996). Radiation conduction interaction: An investigation on silica aerogels. *International Journal of Heat and Mass Transfer*, 39(10), 2115-2130.
- Heinemann, U., Caps, R., & Fricke, J. (1999). Characterization and Optimization of Vacuum Super Insulations. *Vuoto*, XXVIII(N. 1-2 Gennaio-Giugno 1999), 43-46.
- Heinemann, U., Hetfleisch, J., Caps, R., Kuhn, J., & Fricke, J. (1995). *Evacuable Guarded Hot Plate for Thermal Conductivity Measurements between -200°C and 800°C*. Paper presented at the Advances in thermal insulation : proceedings of the Eurotherm seminar no. 44, 18-20 October 95, Espinho, Portugal, Rio Tinto, Portugal.
- Heinemann, U., Huemmer, E., Buettner, D., Caps, R., & Fricke, J. (1986). Silica Aerogel - a Light-Transmitting Thermal Superinsulator. *High Temperatures - High Pressures*, 18(5), 517-526.
- Heinemann, U., & Kastner, R. (2010). *VIP-PROVE: Vakuumisolationspaneele - Bewährung in der Baupraxis. Wissenschaftliche Begleitforschung. Schlussbericht Energieoptimiertes Bauen, ViBau Report ZAE 2-1210-11 (2010) (VIP-PROVE: Vacuum insulation panels - Testing in construction practice. Scientific evaluation. Final report energy optimized construction). [In German]. Retrieved from Würzburg, Germany: [http://www.vip-bau.de/e\\_pages/monitoring/monitoring.htm](http://www.vip-bau.de/e_pages/monitoring/monitoring.htm), [http://www.vip-bau.de/pdf/literatur/BMWi\\_0327321N\\_Schlussbericht%20VIP-PROVE.pdf](http://www.vip-bau.de/pdf/literatur/BMWi_0327321N_Schlussbericht%20VIP-PROVE.pdf)*
- Hot Disk AB. (2013). *Hot Disk Thermal Constants Analyser. Instruction Manual*.
- Ibrahim, M., Biwole, P. H., Achard, P., & Wurtz, E. (2015). Aerogel-Based Materials for Improving the Building Envelope's Thermal Behavior: A Brief Review with a Focus on a New Aerogel-Based Rendering. In A. Sharma & S. K. Kar (Eds.), *Energy Sustainability Through Green Energy, Green Energy and Technology* (1 ed., Vol. 201, pp. 163-188): Springer India.
- Ihara, T., Jelle, B. P., Gao, T., & Gustavsen, A. (2015). Aerogel granule aging driven by moisture and solar radiation. *Energy and Buildings*, 103, 238-248. doi:<http://dx.doi.org/10.1016/j.enbuild.2015.06.017>
- INNOVIP. (2016-2019). Innovative multi-functional Vacuum-Insulation-Panels for use in the building sector, EU H2020, Grant No 723441, Coord.: C. Sprengard, FIW München, Germany. Retrieved from <http://innovip-h2020.eu/>
- International-Organization-for-Standardization-(ISO). (2006). ISO 14040:2006 Environmental management - Life cycle assessment - Principles and framework. Geneva, Switzerland.
- International-Organization-for-Standardization-(ISO). (2008). ISO 22007-2:2008 Plastics- Determination of thermal conductivity and thermal diffusivity -- Part 2: Transient plane heat source (hot disc) method. Geneva, Switzerland.
- Jelle, B. P., Baetens, R., & Gustavsen, A. (2015). Aerogel Insulation for Building Applications *The Sol-Gel Handbook* (pp. 1385-1412): Wiley-VCH Verlag GmbH & Co. KGaA.
- Jelle, B. P., & Kalnæs, S. E. (2016). Nanotech Based Vacuum Insulation Panels for Building Applications. In F. Pacheco Torgal, C. Buratti, S. Kalaiselvam, C.-G. Granqvist, & V.

- Ivanov (Eds.), *Nano and Biotech Based Materials for Energy Building Efficiency* (pp. 167-214). Cham: Springer International Publishing.
- Johansson, P. (2012). *Vacuum Insulation Panels in Buildings: Literature Review*. Retrieved from Göteborg, Sweden: <http://publications.lib.chalmers.se/publication/155961-vacuum-insulation-panels-in-buildings-literature-review>
- Johansson, P. (2014). *Building Retrofit using Vacuum Insulation Panels: Hygrothermal Performance and Durability*. (PhD thesis), Chalmers University of Technology, Department of Civil and Environmental Engineering, Gothenburg, Sweden. Retrieved from <http://publications.lib.chalmers.se/records/fulltext/193780/193780.pdf>
- Kaganer, M. G. (1969). *Thermal Insulation in Cryogenic Engineering*. Jerusalem, Israel: IPST Press.
- Kalnaes, S. E., & Jelle, B. P. (2014). Vacuum insulation panel products: A state-of-the-art review and future research pathways. *Applied Energy*, 116, 355-375. doi:10.1016/j.apenergy.2013.11.032
- Kalwall. (2017). High performance translucent building systems. Retrieved from <https://www.kalwall.com/>
- Karami, P., Al-Ayish, N., & Gudmundsson, K. (2015). A comparative study of the environmental impact of Swedish residential buildings with vacuum insulation panels. *Energy and Buildings*, 109, 183-194. doi:10.1016/j.enbuild.2015.10.031
- Kasser, U., Frischknecht, R., Klingler, M., Savi, D., Stolz, P., Tschümperlin, L., Wyss, F., & Itten, R. (2016). *Erneuerung und Erweiterung der Ökobilanzdaten in der KBOB-Liste "Ökobilanzdaten im Baubereich"*. Retrieved from Bern, Switzerland: [http://treeze.ch/fileadmin/user\\_upload/downloads/Publications/Case\\_Studies/Building\\_and\\_Construction/Schlussbericht\\_Erneuerung\\_und\\_Erweiterung\\_der\\_OEkobilanzdaten\\_in\\_der\\_KBOB-Liste\\_Web.pdf](http://treeze.ch/fileadmin/user_upload/downloads/Publications/Case_Studies/Building_and_Construction/Schlussbericht_Erneuerung_und_Erweiterung_der_OEkobilanzdaten_in_der_KBOB-Liste_Web.pdf)
- Kevothermal. (2017). Nanofloor Insulation. Retrieved from <https://www.ribaproductselector.com/vacuum-insulation-panels-in-an-external-wall-insulation-system/26829/col873957/download.aspx>
- Kiese, S., Küçükpinar, E., Reinelt, M., Miesbauer, O., Ewender, J., & Langowski, H.-C. (2017). A systematic approach for the accurate and rapid measurement of water vapor transmission through ultra-high barrier films. *Review of Scientific Instruments*, 88(2), 025108. doi:10.1063/1.4974952
- Kim, J., Lee, J. H., & Song, T. H. (2012). Vacuum insulation properties of phenolic foam. *International Journal of Heat and Mass Transfer*, 55(19-20), 5343-5349.
- Kingspan. (2017). OPTIM-R. Retrieved from <https://www.kingspan.com/au/en-au/products-brands/insulation/insulation-boards/optim-r>
- Kistler, S. S. (1932). Coherent Expanded Aerogels. *Journal of Physical Chemistry A*, 36(1), 52-64.
- Kistler, S. S. (1935). The Relation between Heat Conductivity and Structure in Silica Aerogel. *J. Phys. Chem.*, 39(1), 79 - 86.
- Koebel, M., Rigacci, A., & Achard, P. (2012). Aerogel-based thermal superinsulation: An overview. *Journal of Sol-Gel Science and Technology*, 63, 315-339. doi:10.1007/s10971-012-2792-9

- Kojima, S., Miyaji, N., Kobayashi, T., & Horibata, F. (2011). *Development of new heat sealing technology "Wave Seal" for long performance of VIPs*. Paper presented at the 10th Int. Vacuum Insulation Symp. (IVIS-X), Ottawa, ON, Canada.
- Kono, J., Goto, Y., Ostermeyer, Y., Frischknecht, R., & Wallbaum, H. (2016) Factors for eco-efficiency improvement of thermal insulation materials. *Vol. 678. Key Engineering Materials* (pp. 1-13).
- Kullberg, R. C., & Bradley, L. P. (2012). *Getters and Design to Reliability: A Tool For Lifetime Assurance*. Paper presented at the International Symposium on Microelectronics, September 9-13, 2012, San Diego, California, USA.  
<https://www.vacuumenergyinc.com/s/Kullberg-IMAPS-2012.pdf>
- Kwon, J. S., Jang, C. H., Jung, H., & Song, T. H. (2009). Effective thermal conductivity of various filling materials for vacuum insulation panels. *International Journal of Heat and Mass Transfer*, 52(23-24), 5525-5532.
- Kwon, J. S., Jung, H., Yeo, I. S., & Song, T. H. (2011). Outgassing characteristics of a polycarbonate core material for vacuum insulation panels. *Vacuum*, 85(8), 839-846.
- Langowski, H.-C. (2008). Permeation of Gases and Condensable Substances through Monolayer and Multilayer Structures. In O. G. Piringier & A. L. Baner (Eds.), *Plastic Packaging: Interactions with Food and Pharmaceuticals* (Second ed., pp. 297-347). Weinheim, Germany: Wiley-VCH Verlag GmbH & Co. KGaA.
- Leventis, N. S., A.; Chandrasekaran, N.; Sotiriou-Leventis, C. . (2010). Click Synthesis of Monolithic Silicon Carbide Aerogels from Polyacrylonitrile-Crosslinked 3D Silica Networks. *Chem. Mater.*, 22, 2790-2803.
- Liebner, F., Aigner, N., Schimper, C., Potthast, A., & Rosenau, T. (2012). Bacterial Cellulose Aerogels: From Lightweight Dietary Food to Functional Materials *Functional Materials from Renewable Sources* (Vol. 1107, pp. 57-74): American Chemical Society.
- Lolli, N., & Hestnes, A. G. (2014). The influence of different electricity-to-emissions conversion factors on the choice of insulation materials. *Energy and Buildings*, 85, 362-373.  
doi:10.1016/j.enbuild.2014.09.042
- Lu, H., Luo, H., & Leventis, N. (2011). Mechanical Characterization of Aerogels. In A. M. A., L. Nicholas, & M. Koebel (Eds.), *Aerogels Handbook* (Vol. 8776, pp. 499-535): Springer.
- Manini, P. (1999a). European Workshop on Vacuum Panel Technology for Superinsulation in Domestic and Industrial Applications, Milano-Italy, 19th November 1998. *Vuoto*, XXVIII(N. 1-2 Gennaio-Giugno 1999), 5-82.
- Manini, P. (1999b). Recent developments in the open cell foam-filled vacuum insulated panels for appliances applications. *Journal of Cellular Plastics*, 35(5), 403-+.
- McNaught, A. D., & Wilkinson, A. (1997). *Compendium of chemical terminology : IUPAC recommendations* (2nd ed / compiled by Alan D. McNaught and Andrew Wilkinson. ed.). Oxford: Blackwell Science.
- Mendenhall, R. (2011). American Aerogel Corporation: Organic Aerogel Commercialization. In M. A. Aegerter, N. Leventis, & M. M. Koebel (Eds.), *Aerogels Handbook* (pp. 857-863). New York, NY: Springer New York.
- Miesbauer, O., Kucukpinar, E., Kiese, S., Carmi, Y., Noller, K., & Langowski, H.-C. (2014). Studies on the barrier performance and adhesion strength of novel barrier films for vacuum

- insulation panels. *Energy and Buildings*, 85, 597-603.  
doi:<http://dx.doi.org/10.1016/j.enbuild.2014.06.054>
- Mocon. (2014). Aquatran\_ Model 1 Operator's Manual – Revision D,  
<http://www.mocon.com/distributor/pdfmanuals/Aquatran%20-%20d.pdf>.
- Morel, B. (2008). *Vieillissement thermohydrrique de silices nanométriques*. Retrieved from  
<http://www.theses.fr/2008TOUR4011/document> Available from  
<http://www.theses.fr/2008TOUR4011>
- Mukhopadhyaya, P., Kumaran, K., Normandin, N., & Reenen, D. v. (2009). *Fibre-powder composite as core material for vacuum insulation panels*. Paper presented at the Proceedings of the 9th international vacuum insulation symposium (IVIS 2009), London, UK.  
[http://oisd.brookes.ac.uk/ivisnet/resources/papers/1D\\_Phalguni%20Mukhopadhyaya.pdf](http://oisd.brookes.ac.uk/ivisnet/resources/papers/1D_Phalguni%20Mukhopadhyaya.pdf)
- Mukhopadhyaya, P., Kumaran, M. K., Sherrer, G., & van Reenen, D. (2011). *An Investigation on Long-Term Thermal Performance of Vacuum Insulation Panels (VIPs)*. Paper presented at the Proc. of 10th Int. Vacuum Insulation Symp. (IVIS-X), Ottawa, ON, Canada.
- Mukhopadhyaya, P., MacLean, D., Korn, J., van Reenen, D., & Molleti, S. (2014a). Building application and thermal performance of vacuum insulation panels (VIPs) in Canadian subarctic climate. *Energy and Buildings*, 85, 672-680.  
doi:<http://doi.org/10.1016/j.enbuild.2014.08.038>
- Mukhopadhyaya, P., Molleti, S., & van Reenen, D. (2014b). Vacuum Insulation Panel (VIP): An Historic Opportunity for the Building Construction Industry. *Interface, technical Journal of RCI, Inc.*, (August 2014). Retrieved from <http://rci-online.org/wp-content/uploads/2014-08-mukhopadhyaya-molleti-vanreenen.pdf>
- Mukhopadhyaya, P., St-Onge, C., Di Lenardo, B., Carbary, L., & Gregg, W. a. P., A. (2015, September 19 – 21). *Long Term Thermal Resistance of Vacuum Insulation Panel (VIP) – Experimental Observations & Predictions*. Paper presented at the Proc. of 12th International Vacuum Insulation Symposium, NUAA, Nanjing, China.
- NAHB Research Center, I. (2002). *Accelerating the Adoption of Vacuum Insulation Technology in Home Construction, Renovation, and Remodeling, Project Final Report*. Retrieved from Upper Marlboro, MD:  
[https://www.huduser.gov/publications/pdf/vip\\_final\\_project\\_report.pdf](https://www.huduser.gov/publications/pdf/vip_final_project_report.pdf)
- NanoInsulate. (2013). *Development of Nanotechnology-based High-performance Opaque & Transparent Insulation Systems for Energy-efficient Buildings, funded by the European Union Seventh Framework Programme (FP7/2007 – 2013) under grant agreement no. NMP4-SL-2010-260086*. Retrieved from  
[http://cordis.europa.eu/result/rcn/172099\\_en.html](http://cordis.europa.eu/result/rcn/172099_en.html)
- Origin. (n.d.). The Origin Windows Brochure. Retrieved from <https://origin-global.com/documents/the-origin-windows-brochure.pdf>
- Pauly, S. (1999). Permeability and Diffusion Data. In J. Brandrup, E. H. Immergut, & E. A. Grulke (Eds.), *Polymer Handbook, 4th Edition, The Wiley Database of Polymer Properties* (pp. VI/543–VI/569): John Wiley & Sons, Inc.
- Phalippou, J., Despetis, F., Calas, S., Faivre, A., Dieudonné, P., Sempéré, R., & Woignier, T. (2004). Comparison between sintered and compressed aerogels. *Optical Materials*, 26(2), 167-172. doi:<http://dx.doi.org/10.1016/j.optmat.2003.11.017>

- Pollanen, J., Shirer, K. R., Blinstein, S., Davis, J. P., Choi, H., Lippman, T. M., Halperin, W. P., & Lurio, L. B. (2008). Globally anisotropic high porosity silica aerogels. *Journal of Non-Crystalline Solids*, 354(40-41), 4668-4674. doi:10.1016/j.jnoncrysol.2008.05.047
- Pons, E., Yrieix, B., Heymans, L., Dubelley, F., & Planes, E. (2014). Permeation of water vapor through high performance laminates for VIPs and physical characterization of sorption and diffusion phenomena. *Energy and Buildings*, 85, 604-616. doi:<http://dx.doi.org/10.1016/j.enbuild.2014.08.032>
- Porextherm. (2017). Vacuapor. Retrieved from <http://www.porextherm.com/en/products/vacuapor.html>
- Prins, W., & Hermans, J. J. (1959). Theory of Permeation through Metal Coated Polymer Films. *Journal of Physical Chemistry*, 63(5), 716-722. doi:DOI 10.1021/j150575a017
- Quenard, D., & Sallee, H. (2005). *From VIP's to building facades: three levels of thermal bridges*. Paper presented at the 7th International Vacuum Insulations Symposium 2005, Duebendorf-Zurich, Switzerland.
- Ramesham, R. (2000). *Getters for Reliable Hermetic Packages* (JPL Publication D-17920 ). Retrieved from California Institute of Technology, Jet Propulsion Laboratory, Pasadena, Ca, US: <https://trs.jpl.nasa.gov/handle/2014/14269>
- Ramesham, R. (2004). *Evaluation of Non-Evaporable Getters for High Vacuum Hermetic Packages* (JPL D-27440). Retrieved from California Institute of Technology, Jet Propulsion Laboratory, Pasadena, Ca, US: [http://www-eng.lbl.gov/~shuman/NEXT/MATERIALS&COMPONENTS/MISC/getter\\_physics.pdf](http://www-eng.lbl.gov/~shuman/NEXT/MATERIALS&COMPONENTS/MISC/getter_physics.pdf)
- Ramesham, R. (2009). *Environmental testing of COTS components for space applications*. Paper presented at the Reliability, Packaging, Testing, and Characterization of MEMS/MOEMS and Nanodevices VIII.
- Ramesham, R., & Kullberg, R. C. (2009). Review of vacuum packaging and maintenance of MEMS and the use of getters therein. *Journal of Micro/Nanolithography, MEMS, and MOEMS*, 8(3), 031307-031307-031309. doi:10.1117/1.3158064
- Reichenauer, G. (2011). Structural Characterization of Aerogels. In M. Aegerter, N. Leventis, & M. Koebel (Eds.), *Aerogels Handbook* (pp. 449-498). New York: Springer-Verlag.
- Reichenauer, G., Heinemann, U., & Ebert, H. P. (2007). Relationship between pore size and the gas pressure dependence of the gaseous thermal conductivity. *Colloids and Surfaces a-Physicochemical and Engineering Aspects*, 300(1-2), 204-210. doi:10.1016/j.colsurfa.2007.01.020
- Rettelbach, T., Sator, D., Korder, S., & Fricke, J. (1996). *Thermal Conductivity of Evacuated Insulating Powders for Temperatures from 10K to 275K*. Paper presented at the 23rd International Thermal Conductivity Conference, Nashville, Tennessee.
- Rockwool. (2011). Innendämmsystem Aerorock® ID (Internal insulation system Aerorock® ID). [In German]. Retrieved from <http://www.rockwool.co.uk/globalassets/rockwool-master/downloads/broschueren/aussenwand/aerorockid.pdf>
- Roiban, L., Foray, G., Rong, Q., Perret, A., Ihiwakrim, D., Masenelli-Varlot, K., Maire, E., & Yrieix, B. (2016). Advanced three dimensional characterization of silica-based ultraporous materials. *RSC Advances*, 6(13), 10625-10632. doi:10.1039/C5RA26014K
- Sachithanadam, M., & Joshi, S. C. (2016). *Silica Aerogel Composites: Novel Fabrication Methods*. Singapore Springer-Verlag.

- Saint-Gobain. (2016). ISOVIP. Retrieved from <http://www.isover.com/news/isovip-high-performance-vacuum-insulation-solution-isover-france>
- Saint-Gobain. (2017a). Lockplate. Retrieved from <https://www.youtube.com/watch?v=kvkn3KkSc2Y>
- Saint-Gobain. (2017b). Slimwall. Retrieved from <https://www.saint-gobain-facade-glass.com/products/slimwall>
- Schüle, R., Aydin, V., Fischer, J., Madry, T., Thomas, S., Becker, D., Bader, N., & Egger, C. (2013). *Improving and Implementing National Energy Efficiency Strategies in the EU Framework, Screening of National Building Regulations Findings from Energy Efficiency Watch II Analyses* Retrieved from [http://www.energy-efficiency-watch.org/fileadmin/eew\\_documents/images/Event\\_pictures/EEW2\\_Logos/EEW-Final\\_Report.pdf](http://www.energy-efficiency-watch.org/fileadmin/eew_documents/images/Event_pictures/EEW2_Logos/EEW-Final_Report.pdf)
- Schwab, H., Heinemann, U., Beck, A., Ebert, H.-P., & Fricke, J. (2005a). Dependence of Thermal Conductivity on Water Content in Vacuum Insulation Panels with Fumed Silica Kernels. *Journal of Thermal Envelope and Building Science*, 28(4), 319-326. doi:10.1177/1097196305051792
- Schwab, H., Heinemann, U., Beck, A., Ebert, H. P., & Fricke, J. (2005b). Permeation of different gases through foils used as envelopes for vacuum insulation panels. *Journal of Thermal Envelope and Building Science*, 28(4), 293-317.
- Schwab, H., Heinemann, U., Beck, A., Ebert, H. P., & Fricke, J. (2005c). Prediction of service life for vacuum insulation panels with fumed silica kernel and foil cover. *Journal of Thermal Envelope and Building Science*, 28(4), 357-374.
- Schwab, H., Heinemann, U., Wachtel, J., Ebert, H. P., & Fricke, J. (2005d). Predictions for the increase in pressure and water content of Vacuum Insulation Panels (VIPs) integrated into building constructions using model calculations. *Journal of Thermal Envelope and Building Science*, 28(4), 327-344.
- Schwab, H., Stark, C., Wachtel, J., Ebert, H.-P., & Fricke, J. (2005e). Thermal Bridges in Vacuum-insulated Building Façades. *Journal of Thermal Envelope and Building Science*, 28(4), 345-355.
- Schwab, H., Wachtel, J., Heinemann, U., Beck, A., & Fricke, J. (2003). *VIP unter baupraktischen Bedingungen, Erfahrungen aus dem Projekt: Vakuumdämmungen für Gebäude (in German only)*. Paper presented at the 1. VIP-BAU, Rostock-Warnemünde, Germany. [http://www.vip-bau.de/pdf/1\\_vip\\_bau/i\\_schwab.pdf](http://www.vip-bau.de/pdf/1_vip_bau/i_schwab.pdf)
- Shufer, E. (2017). *Hanita Methodology for Testing VIPs*. Retrieved from [http://www.hanitacoatings.com/energy/images/energy/files/tech/Hanita\\_Testing\\_Methodology\\_for\\_VIPs\\_Ed\\_C.pdf](http://www.hanitacoatings.com/energy/images/energy/files/tech/Hanita_Testing_Methodology_for_VIPs_Ed_C.pdf)
- Simmler, H., & Brunner, S. (2005). Vacuum insulation panels for building application Basic properties, aging mechanisms and service life. *Energy and Buildings*, 37(11), 1122-1131.
- Simmler, H., Brunner, S., Heinemann, U., Schwab, H., Kumaran, K., Mukhopadhyaya, P., Quenard, D., Sallee, H., Noller, K., Kücükpinar-Niarchos, E., Stramm, C., Tenpierik, M., & Cauberg, H. (2005). *Vacuum Insulation Panels - Study on VIP Components and Panels for Service Life Prediction in Building Applications (Subtask A)*. Retrieved from [http://www.iea-ebc.org/Data/publications/EBC\\_Annex\\_39\\_Report\\_Subtask-A.pdf](http://www.iea-ebc.org/Data/publications/EBC_Annex_39_Report_Subtask-A.pdf)

- Sprengard, C., & Holm, A. H. (2013). *Numerical Examination of Thermal Bridging Effects at the Edges of Vacuum-Insulation-Panels (VIP) in various Constructions*. Paper presented at the 11th International Vacuum Insulation Symposium (IVIS) 2013, Duebendorf-Zurich, Switzerland.  
[https://www.researchgate.net/publication/263729577\\_Proceedings\\_of\\_the\\_11th\\_International\\_Vacuum\\_Insulation\\_Symposium\\_IVIS2013\\_19\\_-\\_20\\_September\\_2013\\_at\\_Empa\\_Duebendorf\\_Switzerland](https://www.researchgate.net/publication/263729577_Proceedings_of_the_11th_International_Vacuum_Insulation_Symposium_IVIS2013_19_-_20_September_2013_at_Empa_Duebendorf_Switzerland)
- Sprengard, C., & Holm, A. H. (2014). Numerical examination of thermal bridging effects at the edges of vacuum-insulation-panels (VIP) in various constructions. *Energy and Buildings*, 85, 638-643. doi:<http://dx.doi.org/10.1016/j.enbuild.2014.03.027>
- Sprengard, C., & Spitzner, M. H. (2011a). Investigations into Ageing and Thermal Bridging in Vacuum Insulation Panels (VIP) for Construction Applications. *Bauphysik*, 33(4), 234-242. doi:10.1002/bapi.201110025
- Sprengard, C., & Spitzner, M. H. (2011b). *Optimierung der energetischen Eigenschaften und der Wirtschaftlichkeit von VIP-Paneelelen durch die optimale Kombination von Kieselsäure-, Mineralfaser- und EPS-Dämmstoff (Optimization of thermal and economic properties of VIP by the optimized combination of fumed silica, mineral fibers and expanded Polystyrene) [in German only – abstract in English]*. Retrieved from Fraunhofer IRB Verlag, Stuttgart: <http://www.irbnet.de/daten/rswb/11059022778.pdf>
- Stadur-Süd. (2017). Stadurwall - Das revolutionäre Innendämmsystem mit Aerogel-Technologie. (Stadurwall - The revolutionary interior insulation system with aerogel technology) [In German]. Retrieved from <http://www.stadurwall.de/>
- Sto. (2017). StoTherm In Aevero - Aerogel Insulation. Retrieved from [http://www.sto.de/de/unternehmen/innovationen/stootherm\\_in\\_aevero\\_1/aerogel\\_daemmung.html](http://www.sto.de/de/unternehmen/innovationen/stootherm_in_aevero_1/aerogel_daemmung.html)
- Tenpierik, M., Spoel, W. v. D., & Cauberg, H. (2008). An Analytical Model for Calculating Thermal Bridge Effects in High Performance Building Enclosure. *Journal of Building Physics*, 31(4), 361-387. doi:10.1177/1744259107088008
- Tenpierik, M. J. (2010). *Vacuum Insulation Panels Applied in Building Constructions*. (Doctoral Thesis), Delft University of Technology, Delft, The Netherlands. Retrieved from <http://books.bk.tudelft.nl/index.php/press/catalog/book/182>
- Torgal, F. P. e., Mistretta, M. e., Kaklauskas, A. e., Granqvist, C. G. e., & Cabeza, L. F. e. (2013). *Nearly zero energy building refurbishment : a multidisciplinary approach*. London: Springer-Verlag.
- va-Q-tec. (2017). va-Q-vip. Retrieved from <http://www.va-q-tec.com/en/products-industries/construction/products.html>
- VARIOTEC. (2017). VIP/QASA. Retrieved from <http://variotec.de/hp2568/Vakuumbaemmung-VIP-QASA.htm>
- Verbeeck, G., & Hens, H. (2005). Energy savings in retrofitted dwellings: economically viable? *Energy and Buildings*, 37(7), 747-754.
- Vermande, H. M., & van der Heijden, J. (2011). *The Lead Market Initiative and Sustainable Construction: LOT 1, Screening of National Building Regulations*. Retrieved from <http://ec.europa.eu/DocsRoom/documents/5082/attachments/1/translations/en/conditions/native>

- Wakili, K. G., Bundi, R., & Binder, B. (2004). Effective thermal conductivity of vacuum insulation panels. *Building Research & Information*, 32(4), 293-299. doi:10.1080/0961321042000189644
- Wang, X., Walliman, N., Ogden, R., & Kendrick, C. (2007). VIP and their applications in buildings: a review. *Proceedings of the Institution of Civil Engineers - Construction Materials*, 160(4), 145-153. doi:10.1680/coma.2007.160.4.145
- WBCSD. (2009). *Transforming the Market: Energy Efficiency in Buildings* Retrieved from <http://www.wbcd.org/Projects/Energy-Efficiency-in-Buildings/Resources/Transforming-the-Market-Energy-Efficiency-in-Buildings>
- Wegger, E., Jelle, B. P., Sveipe, E., Grynning, S., Gustavsen, A., Baetens, R., & Thue, J. V. (2011). Aging effects on thermal properties and service life of vacuum insulation panels. *Journal of Building Physics*. doi:10.1177/1744259111398635
- Wei, G. S., Liu, Y. S., Zhang, X. X., Yu, F., & Du, X. Z. (2011). Thermal conductivities study on silica aerogel and its composite insulation materials. *International Journal of Heat and Mass Transfer*, 54(11-12), 2355-2366. doi:10.1016/j.ijheatmasstransfer.2011.02.026
- Yang, C. G., Li, Y. J., Gao, X., & Xu, L. (2012). A Review of Vacuum Degradation Research and the Experimental Outgassing Research of the Core Material- Pu foam on Vacuum Insulation Panels. *Physics Procedia*, 32, 239-244. doi:<http://dx.doi.org/10.1016/j.phpro.2012.03.549>
- Yrieix, B., Morell, B., & Pons, E. (2014). VIP service life assessment: Interactions between barrier laminates and core material, and significance of silica core ageing. *Energy and Buildings*, 85, 617-630. doi:10.1016/j.enbuild.2014.07.035
- ZAE Bayern, v.-b. d. (2016). Retrieved from <http://www.vip-bau.de/>
- Zhuravlev, L. T. (2000). The surface chemistry of amorphous silica. Zhuravlev model. *Colloids and Surfaces a-Physicochemical and Engineering Aspects*, 173(1-3), 1-38. doi:10.1016/S0927-7757(00)00556-2







[www.iea-ebc.org](http://www.iea-ebc.org)